

# ***HYDRAMASTER***

---

Corporation  
11015 47th Avenue W, Mukilteo, WA 98275

## **CDS 4.2 / 4.7**

Machine Serial Number \_\_\_\_\_

Copyright © 1999  
HYDRAMASTER® Corporation  
Mukilteo, Washington

182-008

No part of this manual may be reproduced or used in any form or by any means (i.e. graphic, electronic, photocopying or electronic retrieval systems) without the express written permission of the HYDRAMASTER® Corporation. All rights reserved.

Revised November 22, 1999

---

# *Table of Contents*

*CDS 4.2 / 4.7*

<b>GENERAL INFORMATION</b> .....	<b>Section 1</b>
Telephone Numbers .....	1-2
System Operation .....	1-3
Machine Specifications .....	1-4
Spare Parts Recommendation .....	1-7
Spare Parts List .....	1-7
Purchaser's/Salesman's Responsibility .....	1-9
Local Water Precautions .....	1-11
Wastewater Disposal Advisory .....	1-13
Map .....	1-15
<b>CLEANING PROCEDURES</b> .....	<b>Section 2</b>
PH Chart .....	2-4
<b>OPERATING INSTRUCTIONS</b> .....	<b>Section 3</b>
Start Up .....	3-2
Shut Down .....	3-2
Precautions .....	3-4
<b>FREEZE GUARD</b> .....	<b>Section 4</b>
Vacuum Freeze Guard Procedure .....	4-1
Freeze Protection for Clutch .....	4-3

# *Clutch Drive System*

---

<b>WATER AND CHEMICAL SYSTEMS</b> . . . . .	<b>Section 5</b>
Water Flow Diagram . . . . .	5-3
Proportioner Diagram . . . . .	5-4
Chemical Tank Troubleshooting . . . . .	5-5
<b>HIGH PRESSURE PUMP</b> . . . . .	<b>Section 6</b>
Pump Maintenance . . . . .	6-1
Pump Service of Wet End . . . . .	6-3
Pump Service of Hydraulic End . . . . .	6-8
Pump Troubleshooting . . . . .	6-13
Assembly Drawings and Parts Lists . . . . .	6-15
<b>CDS PARTS LISTINGS</b> . . . . .	<b>Section 7</b>
Machine Assembly Drawings and Parts Lists . . . . .	7-1
CDS Belts . . . . .	7-36
Cleaning Wand Assembly Drawings and Parts List . . . . .	7-38
By-Pass Valve Assembly Drawing and Parts List . . . . .	7-43
<b>VACUUM SYSTEM</b> . . . . .	<b>Section 8</b>
Lubrication Instructions . . . . .	8-4
Blower Troubleshooting . . . . .	8-5
Roots Blower Instruction Booklet	
<b>ELECTRICAL SYSTEM</b> . . . . .	<b>Section 9</b>
Vanguard System . . . . .	9-1
Wiring Schematic . . . . .	9-3

# *Clutch Drive System*

---

Wiring Diagrams . . . . .	9-4
Electrical Troubleshooting . . . . .	9-6
<b>MAINTENANCE AND REPAIR . . . . .</b>	<b>Section 10</b>
Daily, Weekly . . . . .	10-1
Monthly, Quarterly, Yearly . . . . .	10-2
De-scaling . . . . .	10-3
Overall Care . . . . .	10-3
Drive Shaft Maintenance . . . . .	10-5
Troubleshooting . . . . .	10-6
Maintenance Logs	
<b>HOW TO ORDER PARTS . . . . .</b>	<b>Section 11</b>
<b>WARRANTY INFORMATION . . . . .</b>	<b>Section 12</b>
Golden Guarantee®	
<b>ACCESSORIES . . . . .</b>	<b>Section 13</b>
<b>PRODUCT UPDATES . . . . .</b>	<b>Section 14</b>

---

# *Introduction*

*CDS 4.2 / 4.7*

*Section 1-1*

**T**his manual contains installation and operation instructions as well as information required for proper maintenance, adjustment and repair of this unit. Since the first and most important part of repair work is the correct diagnosis of the problem, component manual troubleshooting charts have been included for your convenience.

Unlike a garden tractor, lawn mower or cement mixer, all having one or two functions to perform, the truck-mounted carpet cleaning plant has many functions to perform simultaneously.

- ▶ The engine has to run at a consistent RPM.
- ▶ The vacuum has to pull air and dirty water back from cleaning site.
- ▶ The water pump provides stable pressure at proper water flow for cleaning.
- ▶ The chemical has to be injected into the water stream at the right concentration.
- ▶ The heating system must maintain proper heat.
- ▶ The vacuum tank must store dirty water until drained.

As you can see, it is not just a turn-key operation with one thing to worry about, **Does it start?!**

◆ WARNING ◆

The manufacturer uses this symbol throughout the manual to warn of possible injury or death.

◆ CAUTION ◆

This symbol is used to warn of possible equipment damage.

HOURS	TELEPHONE NUMBERS
Monday - Friday	(425) 775-7276 Parts
8:00 am to 5:00 pm	(425) 775-7275 Service
PACIFIC STANDARD TIME	(800) 426-4225 Parts / Service FAX

---

# *System Operation*

*CDS 4.2 / 4.7*

*Section 1-3*

**T**he HydraVan CDS machines are highly engineered cleaning plants developed by HydraMaster Corporation. The system utilizes the most current technology available in water heating and water recovery systems.

The system works as follows:

Water is fed into the machine under tap pressure. The water enters the machine and is combined with cleaning solution as it enters the mix tank. The cleaning solution is picked up from the mix tank by the high pressure pump and pumped under pressure through the heating system and then out to the cleaning tool.

After the water is applied to the carpet, it is recovered by the vacuum system and carried back to the recovery tank.

As there is no guess work in the manufacture of these highly advanced cleaning plants, there must be none in preparing it to get the job done in the field. It is the purpose of this manual to help you properly understand, maintain, and service your cleaning plant. Follow the directions carefully and you will be rewarded with years of profitable, trouble-free operation.

It is imperative that no section be overlooked when preparing for operation of this equipment.

---

# *Machine Specifications*

**CDS 4.2 / 4.7**

**Section 1-4**

**DIMENSIONS:** 4.2 - 10"W x 65"L x 38"H  
4.7 - 13"W x 68"L x 38"H

**WEIGHT:** 4.2 - 500 lbs.  
4.7 - 575 lbs.

**CONSTRUCTION:**

Tank and Chassis: Marine Aluminum with Baked-on Epoxy finish  
Cowling: Fiberglass

**POWER TRANSFER:** Electronic, Key Activated

**VACUUM BLOWER:** 4.2 - 45 *WhispAir*, Dual Shaft  
4.7 - 47 *WhispAir*, Dual Shaft

**WATER PUMP:** Triple Diaphragm  
Withstands up to 300° F

**CHEMICAL SYSTEM:** Electro-Mechanical, Meter Controlled

**HEATING SYSTEM:** Multiple Heat Exchanger (600 PSI pres)  
Dual Shell and Tube Exchangers

**INSTRUMENTS:**

Main Panel:

Electronic Tachometer, 0-3000 RPM  
Water Temperature Gauge, 0-280° F  
Hour Meter, Machine Run-Time  
Keyed Ignition, Start/Stop  
Chemical Flowmeter, Clear Acrylic, 0-10 GPH  
Electronic Circuit Protection Breaker, Re-settable



Side Panel:

Water Pressure Gauge, Liquid Filled, 0-1000 PSI  
Vacuum Level Gauge, 0-30" HG  
Blower Lubrication Port  
Water Pressure Adjustment  
Water Temperature Adjustment Knob and Exchanger By-pass  
High Pressure Solution Outlets, Quick-Disconnect (2)  
Fresh Water Inlet Fitting, Quick-Disconnect  
Mix Tank Drain Valve

**RECOVERY TANK:** 4.2 - 90 gallon, Aluminum  
4.7 - 120 gallon, Aluminum

**CLEANING WAND:** Stainless Steel Wand  
Stainless Steel Solution Valve and Tube  
Jet Splash Guards  
Insulated Handle Sleeve  
Height Adjustable Handle

**STANDARD EQUIPMENT:** Power Transfer Package  
Component Power Pack  
Equipment Cowling w/ Armrests  
Vacuum Recovery Tank  
Control Console  
Dual Wand Hook-up  
HydraMaster Heat Exchanger System  
Freeze Guard System  
Wheel Chock Set  
Carpet Wand  
150', 2" Vacuum Hose  
10', 1 1/2" Vacuum Hose  
150', HP Solution Line  
50', Fresh Water Hose  
10', 1 1/2" Drain Line  
5 Gallon Chemical Jug  
Chemical Jug Holder  
Chemical Jug Fill Line

Van Finish Package  
Van-Sentry System  
Van Decal Package  
Monogrammed Jacket  
Operation Manual  
Custom Equipment Color

Additional 4.7 Equipment:

Oversize Air Handling Package  
405 CFM High-Output Vacuum System  
Expanded Vacuum Recovery Tank Capacity  
*HushKit* Silenced System

---

# Spare Parts

**CDS 4.2 / 4.7**

**Section 1-7**

**D**own-time on the unit can be very expensive, because your truck-mounted unit is capable of generating several hundred dollars per day. In order to minimize such down-time, it is strongly recommended by the manufacturer that you purchase and keep in your truck the parts listed below.

## Parts Orders

**To expedite your parts needs, please call your sales representative.** In most instances, he either stocks or has access to parts through a regional service center. If further assistance is needed, contact the factory and coordinate your needs. If this becomes necessary, always indicate the method of shipment you desire, i.e. UPS, Blue Label, Air Freight, Air Express, etc.

HydraMaster Parts Dept. Phone . . . . . (425) 775-7276  
HydraMaster Parts Dept. Toll Free Fax . . . . . 1-800-426-4225

## 078-098 Parts List (4.2)

PART NO	DESCRIPTION	QTY
169-022	Valve, 1 ½ Full Port Ball	1
157-022	Switch, Relay	1
157-007	Switch, 12 VDC Lighted	2
078-102	Kit, Pressure By-pass Valve	1
078-019	Kit, Wand Valve Plunger	1
078-018	Kit, Diaphragm Hi PSI Pump	1
078-015	Kit, Flow Meter	1
076-005	Spray Jet 8006E	1
057-043	Gasket, Recovery Tank	1
052-053	Quick Connect, 660 Female	1

---

PART NO	DESCRIPTION	QTY
052-052	Quick Connect, 660 Male	1
052-051	Quick Connect, 440 Female	2
052-050	Quick Connect, 440 Male	2
049-030	Filter Bag, Recovery Tank	6
049-023	Screen, Garden Hose	6
049-007	Filter, s/s Vacuum (4.2)	1
010-016	Belt, AX30	1

## 078-099 Parts List (4.7)

---

PART NO	DESCRIPTION	QTY
169-022	Valve, 1 ½ Full Port Ball	1
157-022	Switch, Relay	1
157-007	Switch, 12 VDC Lighted	2
078-102	Kit, Pressure By-pass Valve	1
078-019	Kit, Wand Valve Plunger	1
078-018	Kit, Diaphragm Hi PSI Pump	1
078-015	Kit, Flow Meter	1
076-005	Spray Jet 8006E	1
057-043	Gasket, Recovery Tank	1
052-053	Quick Connect, 660 Female	1
052-052	Quick Connect, 660 Male	1
052-051	Quick Connect, 440 Female	2
052-050	Quick Connect, 440 Male	2
049-030	Filter Bag, Recovery Tank	6
049-023	Screen, Garden Hose	6
049-013	Filter, s/s Vacuum (4.7)	1
010-022	Belt, CDS Pump Drive	1

---

# *Responsibilities*

**CDS 4.2 / 4.7**

**Section 1-9**

**P**rior to the arrival of the unit, the van that it will be installed in should be delivered to the installer.

## **PURCHASER'S RESPONSIBILITY**

It is the purchaser's responsibility to **Read the Owner's Manual** and to familiarize yourself with the information contained therein. *Special attention should be paid to all **Cautions and Warnings**.*

## **SALES REPRESENTATIVE'S RESPONSIBILITY**

### **Acceptance of Shipment**

1. If the unit shows any outward signs of damage, do not sign the delivery receipt until you have closely inspected the unit and noted any damage on the delivery receipt.
2. The salesman from whom you purchased your unit is responsible for supervising the correct installation of the unit in your vehicle and thoroughly training you in its operation, maintenance and precautions.

### **Installation**

- ▶ Correctly installing the unit and recovery tank in your vehicle and securing them with bolts and tie down washers.
- ▶ Checking the pump, vacuum blower and engine oil levels prior to starting the unit.
- ▶ Starting the unit to check the drive system and see that all other systems function normally.

- ▶ Checking all hoses, wands, etc. for correct operation.

## **Training**

- ▶ A thorough review of the operation manual with the purchaser.
- ▶ Instruction and familiarization in: how to correctly start up and shut down the unit, how to correctly clean with the unit, where and how often to check and change component oil levels, how the unit's systems work, how to troubleshoot the unit, how to do basic repairs, safety precautions and their importance, freezing damage and how to avoid it, hard water damage and how to avoid it.
- ▶ A thorough review of the unit warranty and warranty procedures.
- ▶ A thorough review of hard water precautions and warnings.
- ▶ How to determine hard water areas.
- ▶ Use of water softening systems.

---

# *Local Water Precautions*

*CDS 4.2 / 4.7*

*Section 1-11*

The quality of water varies greatly. Many areas have an excess of minerals in the water which results in what is commonly called "hard water." These minerals tend to adhere to the insides of heater coils and other parts of the machines causing damage and a loss of cleaning effectiveness. This influences the reliability and efficiency of equipment in direct proportion to the level of hardness.

## **HARD WATER ADVISORY**

HydraMaster recognizes that any hard water deposits which might occur within the water system of our truckmounts is a serious problem. The precision technology of truckmount heat exchanger systems is intolerant of any foreign material. Hard water deposits will ultimately decrease the performance of the system and are expected to seriously lower the reliability of the machine.

To validate a machine's warranty, HydraMaster requires that all machines operating in designated "Hard Water Areas" (3.5 grains or more per gallon) be fitted with a water softening system or a properly installed magnetic-type de-scaler must be used and maintained. Periodic de-scaling or acid-rinsing alone is *not* adequate in these areas. HydraMaster does not recommend any particular type or brand, however the relative effectiveness of some types of magnetic de-scalers or softeners may require additional periodic use of de-scaling agents.

HydraMaster also recommends, in the strongest possible terms, that machines in *all areas* be fitted with a water softening system for improved operation and reliability.

**HydraMaster has included five hard water test strips with your machine.** These can be used to test the water in your immediate and surrounding areas as they can vary greatly. Assume all water obtained from wells is hard.

◆ CAUTION ◆

Failure to take appropriate measures to prevent scale build up can result in **system failure** and **loss of warranty** on affected parts.

## HARD WATER AREA MAP

The following map defines areas in the United States which compromise fluid related components such as hoses, fittings, heaters, pumps, valves and water cooled engines. For other countries, hard water area maps can be obtained from geological societies.

## WATER SOFTENER

Cleaning efficiency and equipment life is increased, chemical use decreased, and the appearance of cleaned carpets enhanced when water softeners are incorporated in hard water areas. The manufacturer strongly urges the use of water softener units in areas exceeding 3½ grains per gallon. Failure to use a water softener in these areas will invalidate the machine's warranty. Using a hard water area map as a reference, determine the quality of water in your area and take action immediately, if necessary.

Reports from several of our machine users commending the results of the use of water softeners in conjunction with their machines prompts us to recommend the procedure to everyone in a "hard water" area.

The relatively low cost of a water softener service is more than made up for by an increased life of machine parts, reduced chemical costs and continued cleaning efficiency. The water softener will also increase the *effectiveness* of the cleaning chemicals, therefore less chemical will be needed.



Contact a water softener distributor in your area for information on the rental of a simple water treatment unit to carry in your truck. Be sure to change the water softener in accordance with the capability of the softener. For example: If the softener will treat 900 gallons of water and the machine uses an average of 30 gallons per hour, for an average of 5 hours a day, this equals 150 gallons per day. In 6 days the machine would use 900 gallons of water. Therefore, the softener would need to be changed every 6 working days for maximum softening.

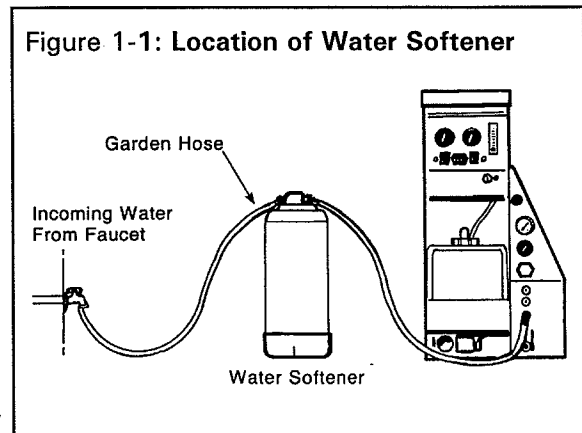

## WASTE WATER DISPOSAL ADVISORY

There are laws in most communities prohibiting the dumping of recovered "gray" water from carpet cleaning in any place but a sanitary treatment system.

This cleaning rinse water, recovered into your unit's vacuum tank, contains materials such as detergents. These must be processed before being safe for streams, rivers and reservoirs.

**IN ACCORDANCE WITH THE EPA, STATE AND LOCAL LAWS, DO NOT DISPOSE OF WASTE WATER INTO GUTTERS, STORM DRAINS, STREAMS, RESERVOIRS, ETC.**

In most cases, an acceptable method of waste water disposal is to discharge into a municipal sewage treatment system after first filtering out solid material such as carpet fiber. Access to the sanitary system can be obtained through a toilet, laundry drain, RV dump, etc. Permission should first be obtained from any concerned party or agency.

One disposal method which usually complies with the law is to accumulate the waste water and haul it to an appropriate dump site. Another solution to the disposal problem is to equip yourself with an Automatic Pump-Out System.

These systems are designed to remove waste water from the extractor's recovery system and actively pump the water through hoses to a suitable disposal drain. Properly designed, they will continuously monitor the level of waste water and pump it out simultaneously to the cleaning operation. The hidden benefit of this process is that the technician does not have to stop his cleaning to empty the recovery tank. HydraMaster makes an A.P.O. System available which can be ordered with new equipment or installed later.

The penalties for non-compliance can be serious. Always check local laws and regulations to be sure you are in compliance.

Figure 9-1 Hard Water Map

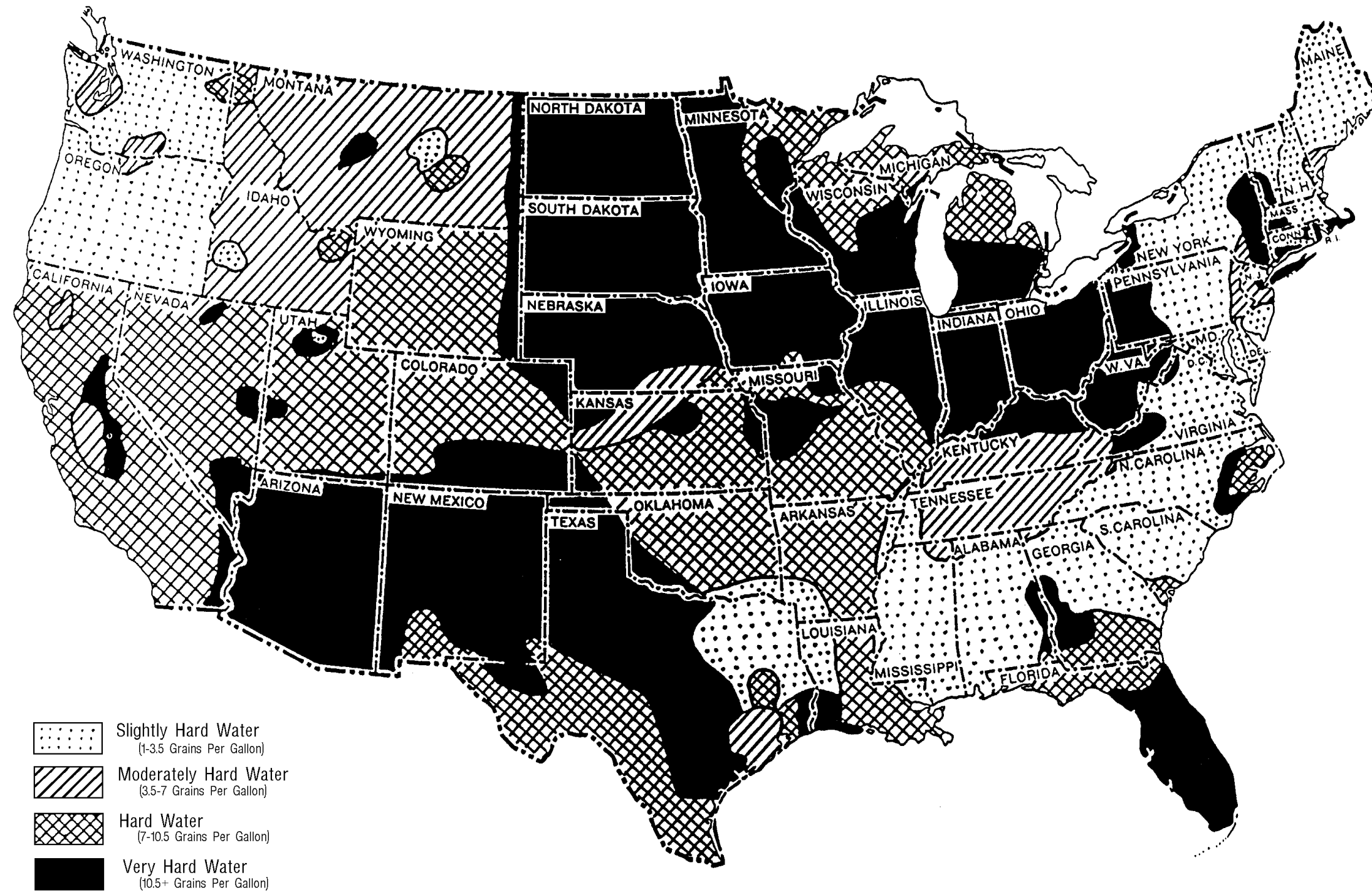

Source: Water Treatment Fundamentals, Water Quality Association, 1996.

---

# *Cleaning and Chemicals*

*CDS 4.2 / 4.7*

## *Section 2-1*

**Y**our mobile carpet cleaning plant has been engineered using the latest and most sophisticated technology available to produce the finest carpet cleaning results possible. Despite this, however, it remains only a tool of the carpet cleaning trade, and it can produce only as good a job as the person operating it.

### **PRECAUTIONS**

There are no short cuts to good carpet cleaning. It requires time, cleaning knowledge and the use of good chemicals. Therefore, the manufacturer recommends the use of spotting agents and traffic lane cleaners, as required, prior to the actual cleaning of carpeting.

The use of some chemicals through your mobile carpet cleaning plant can seriously damage the internal plumbing, high pressure pump and heater. These harmful chemicals include concentrated acid (see the pH chart at the end of this section), solvents, and some paint, oil, and grease removers with a high concentration of solvents.

The manufacturer recommends only the use of chemicals containing rust and corrosion inhibitors and water softening agents to prevent chemical build-up which may lead to component failure and warranty invalidation.

**◆ CAUTION ◆**

The increased demand for "clear water" rinsing results in the need for special care when using these acid based chemicals in your equipment. The negative side of these products is the corrosive effects the acid can have on metals, including swivels, pumps, heat exchangers, etc.

HydraMaster's *ClearWater Rinse* has been formulated to protect vital components. HydraMaster will not warranty parts that have been damaged from using unprotected acid products that have obviously caused failures.

## **CLEANING STROKE PROCEDURE**

Purpose: To eliminate excess moisture remaining in the carpet fiber and the sawtooth appearance which results from diagonal movement of the cleaning tool on all types of carpet.

Procedure: Always move the cleaning tool in smooth, forward and backward strokes. Apply slight pressure to the forward stroke while the solution is injected into the carpet. When extracting (drying), apply firm pressure on the forward stroke to ensure a positive "lock" for the vacuum and minimize the "hopping" effect resulting on carpet that is not smooth. During the forward and reverse strokes, movement to the right or left should only be accomplished at the extreme rear of the stroke. Overlapping is also important to ensure even application of solution and prevent saturation when cleaning wand is stopped twice at the same point at the rear of the cleaning stroke. This is illustrated at the end of this section.

Failure to adopt this procedure can result in increased chance of 'clean streaks', fiber shrinkage, brown-out and longer drying periods.

## **OVER-WETTING**

Over-wetting is annoying to all concerned, and sometimes leaves a bad impression of the cleaning process used.

### **THESE ARE SEVERAL AREAS THAT WILL CAUSE OVER-WETTING**

1. Too few vacuum strokes or improper saw-tooth vacuum strokes as shown in the following illustration.
2. Obstructed, cut or kinked hoses.

3. Vacuum tank drain valve left partially open.
4. Clogged vacuum blower filter or vacuum tank lid not sealing properly.
5. Cleaning a heavily foam-saturated carpet without defoamer. (We recommend crystal type.)

Figure 2-1

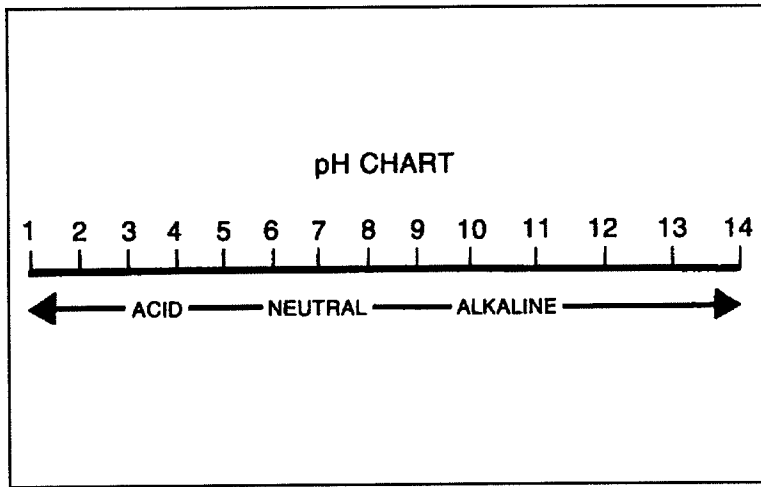
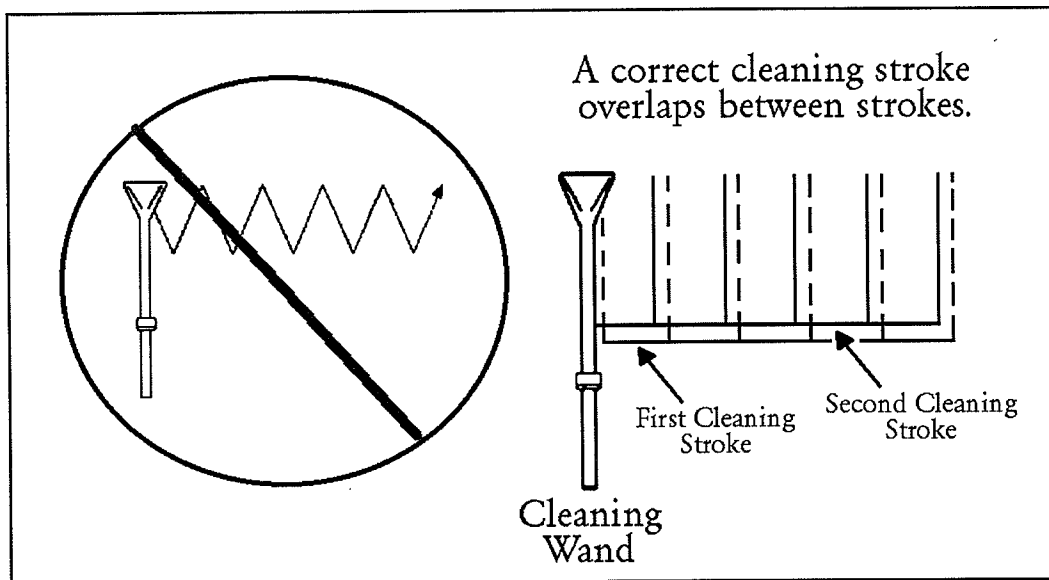

Figure 2-2: **CLEANING STROKE PROCEDURE**



---

# *Operating Instructions*

*CDS 4.2 / 4.7*

*Section 3-1*

## **BEFORE OPERATING THE UNIT**

1. Operate the unit and equipment only in a well ventilated area.

◆ CAUTION ◆

Exhaust fumes contain carbon monoxide and may be hazardous to your health. *Do not operate* this unit or truck where the exhaust may enter any building doorway, window, vent, or opening of any kind.

2. Check the fuel tank to be certain there is adequate fuel to complete the job.
3. Position the wheel chocks on one of the front tires.
4. If using a water supply hose which has not been used recently or if using a customer's hose, first connect the hose to the faucet and flush out any debris which may be in the hose. Afterwards connect the hose to the unit.
5. Check your chemical jug to see if you have enough concentrated chemical to finish the job. If not, mix and fill a five gallon chemical jug. When the mix tank begins a fill cycle, the chemical flowmeter may be adjusted to your desired setting. Set your cleaning pressure at 300 PSI. **NOTE:** A chemical flowmeter set a 5 GPH is a 1 to 30 mix ratio and 10 GPH is a 1 to 15 ratio. When the flowmeter is set at 10 GPH, you will be using what most chemical manufacturers recommend at 5 GPH.
6. Connect all required hoses.
7. When connecting the pressure hose to the pressure outlet connections at



the front of the unit, go to the farthest area to be cleaned and connect to the cleaning tool. This insures that you have the proper length of hose required to perform the cleaning.

## START UP

1. Make sure the van gear select lever is in the Park position and the emergency brake is set.
2. Start the van engine.
3. Turn key on unit. The RPM will automatically increase to the proper running speed.
4. Pull the heat control valve open.  
**NOTE:** For Dodge units only, before operating the unit, slide the heat control knob on the dash of the van to "Hot." If this is not done you may experience reduced heating performance.
5. Now proceed with the cleaning operation.  
**NOTE:** The machine will automatically shut down when it reaches its full capacity due to the float switch located inside the waste tank. When this occurs, empty the waste tank. Then turn the unit back on and continue to clean.

## SHUT DOWN

1. Shut off the knob on the chemical flowmeter.
2. Run fresh water through the chemical mix tank, heat exchangers and cleaning tools.  
**NOTE:** Vinegar should be rinsed through the system weekly. De-scaler should be rinsed through the entire system monthly.
3. Lay vacuum hoses out in order for all moisture to be removed from the

hoses. This prevents spillage of any dirty solution in your vehicle when storing the hoses.

4. Disconnect the hoses and put them away.
5. Allow the unit to run for a few minutes with the vacuum hose disconnected in order to remove all moisture from the vacuum pump. Next plug the vacuum inlets. Spray lubricant into the lube port located on the front panel above the pressure gauge while the unit is running. Spray for about 10 to 15 seconds. This will lubricate the vacuum pump and prevent it from rusting.  
**NOTE:** If freeze guarding is necessary, perform the freeze guard procedure at this time.
6. Turn the machine off.
7. If you are using an outside water source, turn the water supply faucet off. Bleed pressure out of the supply hose by loosening the hose at the water supply. Unhook the water supply hose and store it in the vehicle.
8. Drain the waste tank. Do not dump waste in any area which might violate local, state or federal law. Use the pump-out system to drain the waste tank into a sanitary drain system. When the waste tank is drained, lift waste tank lid and remove the filter bag. Clean out any accumulated debris. Rinse. Re-install.

---

# Precautions

**CDS 4.2 / 4.7**

**Section 3-4**

◆ CAUTION ◆

**THROUGH-FLOOR DRILLING:** Be cautious when drilling holes through the van floor. Many vans have critical components mounted directly below the van floor that could be damaged by a misplaced drill bit. (See Product Support Bulletins 92102, 94062 and 94063 at the end of the manual.)

◆ CAUTION ◆

**LEVEL OPERATION:** During operation, van or trailer must be parked on level ground not to exceed + or - 10 degrees. Failure to insure proper leveling may prevent proper internal lubrication of engine, vacuum and/or high pressure components.

◆ WARNING ◆

**MOVING PARTS:** Never touch any part of the machine that is in motion. Severe bodily injury may result.

◆ CAUTION ◆

**ACID RINSE AGENTS:** The increased demand for "clear water" rinsing results in the need for special care when using these acid based chemicals in your equipment. The negative side of these products is the corrosive effects the acid can have on metals, including swivels, pumps, heat exchangers, etc.

HydraMaster's *ClearWater Rinse* has been formulated to protect vital components. HydraMaster will not warranty parts that have been damaged

from using unprotected acid products that have obviously caused failures.

◆ CAUTION ◆

**FREEZE PROTECTION:** There is often little warning before a cold spell. Therefore, not protecting this equipment from freezing will result in costly down-time. Placing an electric heater in the truck or parking the truck indoors will help to insure against freezing, but should not be the primary method of freeze protection.

◆ WARNING ◆

**HOT SURFACES:** During the operation of this equipment, many surfaces on the machine will become very hot. When near the van for any reason care must be taken not to touch any hot surface.

◆ WARNING ◆

**HEARING PROTECTION:** The Occupational Safety and Health Administration (OSHA) recommends the use of hearing protection when a technician is exposed to an *average* of 85 decibels (this is an average of exposure over an 8 hour period). This equipment can produce 85 decibels to a distance of 10 feet. Please check with your local state agencies to see if OSHA standards apply to your application.

◆ WARNING ◆

**NO SMOKING:** It is unsafe to smoke in or around the vehicle.

◆ WARNING ◆

**CARBON MONOXIDE:** This unit generates toxic fumes. Position the vehicle so

that the fumes will be directed **away** from the job site. **Do not park** where exhaust fumes can enter a building through open doors, windows, air conditioning units or kitchen fans.

◆ WARNING ◆

**TOXIC FUMES:** Do not occupy the vehicle when the cleaning equipment is operating. Toxic fumes may accumulate inside a stationary vehicle.

◆ WARNING ◆

**ENGINE EXHAUST:** The engine exhaust from this product contains chemicals known to the State of California to cause cancer, birth defects or other reproductive harm.

◆ WARNING ◆

**PORTABLE GAS CANS:** Never operate this machine with a portable gas can inside the truck. Doing so increases the risk of a fire or explosion.

◆ WARNING ◆

**PORTABLE PROPANE TANKS:** Do not use a portable propane tank inside of the truck or van. It is dangerous and illegal in most states.

◆ WARNING ◆

**TRANSPORTATION OF FUEL CONTAINERS:** Transportation in a vehicle of any vented fuel container that presently has or has ever contained a flammable liquid is strictly forbidden by HydraMaster Corporation and by federal and state regulation.

---

# *Freeze Guard*

*CDS 4.2 / 4.7*

*Section 4-1*

**A**ny freezing of this machine is not covered by warranty and during the colder months of operation, careful protection should be of utmost concern.

The Following Precautions are Recommended:

1. Run the machine before leaving for the first job to insure nothing has frozen the night before, including hoses and wand.
2. Insulate the garden hose from the cold ground by running it through an extra 1 1/2 inch vacuum hose.
3. Leave truck doors closed until time cleaning begins, afterwards open slightly.
4. In colder climates, insulating the truck walls and floor boards will help protect the unit.
5. Do not procrastinate during the cleaning operation or the hot water solution line will also freeze on the ground. The solution line should be insulated in extremely cold climates.
6. Whenever possible, the truck should be stored in a heated garage at night or over the weekend. If not possible, place a 1500 watt electric heater inside the truck, aimed directly at the machine. Never use a propane heater. It causes excessive moisture on the truck ceiling and the possibility of it going out is higher. If the machine and truck are left outside with a heater, you should first drain of possible water from the machine cleaning tools and hoses. (They freeze also.)

To Drain the Machine Follow These Steps:

- A. Before shutting off the machine, remove the chemical line from the chemical jug and place in a mixture of 50/50 antifreeze and water. With the cleaning tool on, allow mixture to fill chemical system back to the chemical mix tank.
- B. Open the mix tank drain valve and allow the water to drain thoroughly from the mix tank.

C. Remember to close the drain valve prior to next operation of your unit.

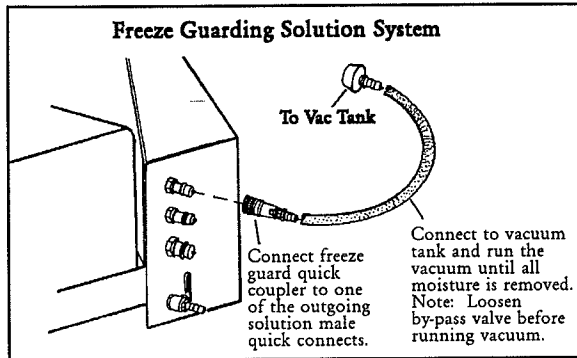

Figure 4-1

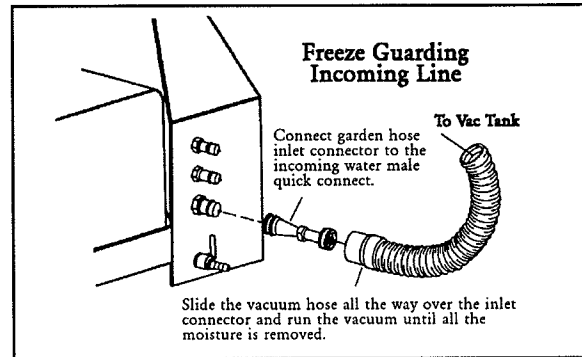

Figure 4-2

Check ENGINE Antifreeze regularly.

◆ CAUTION ◆

One manufacturer of antifreeze cautions: "WHEN DISPOSING OF USED ANTIFREEZE COOLANT: Follow local laws and regulations. If required, dispose at facilities licensed to accept household hazardous waste. If permitted, dispose in sanitary sewer systems. Do not discard into storm sewers, septic systems, or onto the ground."

◆ WARNING ◆

This warning appears on the label of one brand of antifreeze: "HARMFUL OR FATAL IF SWALLOWED. Do not drink antifreeze coolant or solution. If swallowed, induce vomiting immediately. Call a physician. Contains Ethylene Glycol which caused birth defects in animal studies. Do not store in open or unlabeled containers.

KEEP OUT OF REACH OF CHILDREN AND ANIMALS."

*BE SURE YOUR MACHINE IS PROTECTED! Freezing will cause GRIEF, MONEY, and DOWN-TIME.*

## **FREEZE PROTECTION OF THE PUMP-IN SYSTEM**

1. Drain the fresh water tank.
2. Remove the garden hose adapter from the pump-in pump hose and position the hose so it is pointing outside the van.
3. Turn on the pump-in pump and run for 1-2 minutes till all the water is purged from the hose.

**NOTE:** The next time the unit is used it may take a few minutes before the mix tank begins to fill.



---

# *Water and Chemical System*

*CDS 4.2 / 4.7  
Section 5-1*

**T**his electro-mechanical system has been designed to be simple and trouble free.

## **WATER/CHEMICAL FLOW OPERATION**

Incoming water flows first through the Solenoid Control Valve and the low pressure Chemical injector which are both mounted on the exterior of the mix tank. As the water passes through the Chemical injector, it is automatically proportioned with a predetermined quantity of detergent. The Mix Tank is equipped with a Water Level Float which responds to the level in the tank and will maintain the proper volume of solution to be reserved for the water pump.

The desired chemical injection ratio may be obtained by an adjustment of the Chemical Flowmeter during the fill cycle of the mix tank. Water must be flowing into the mix tank in order to adjust the chemical mix. The chemical will flow from the Chemical Jug to the Chemical Flowmeter, then to the Chemical injector where it is proportioned into the Mix Tank at the desired chemical setting.

**NOTE:** With this unique chemical system, the chemical flow is proportioned only during the filling cycles of the Mix Tank, not during the direct spraying of the wand. Therefore, it is possible that as your wand is spraying, you may have no chemical flow. Also, the converse is true in that you may not be spraying your wand, but if the mix tank is in a filling cycle, your Chemical Flowmeter may be active at the desired flow rate.

The chemical proportioning system will mix chemical with water at a 1 to 30 ratio when the Flowmeter is set at 5 GPH, or a 1 to 15 ratio when the Flowmeter is set at 10 GPH.

## **CHEMICAL SYSTEM MAINTENANCE**

The chemical lines may need to be flushed with vinegar periodically to prevent abnormal chemical build-up. This flushing may be done by removing the clear plastic hose from the Chemical Jug and inserting it into a one quart container of vinegar. This should be done with the Chemical Flowmeter setting 10 GPH. Simply spray water from the wand until the quart of vinegar is exhausted. Then repeat the process with one quart of clear water to void all lines of vinegar.

Figure 5-1: Flow Diagram

D2975

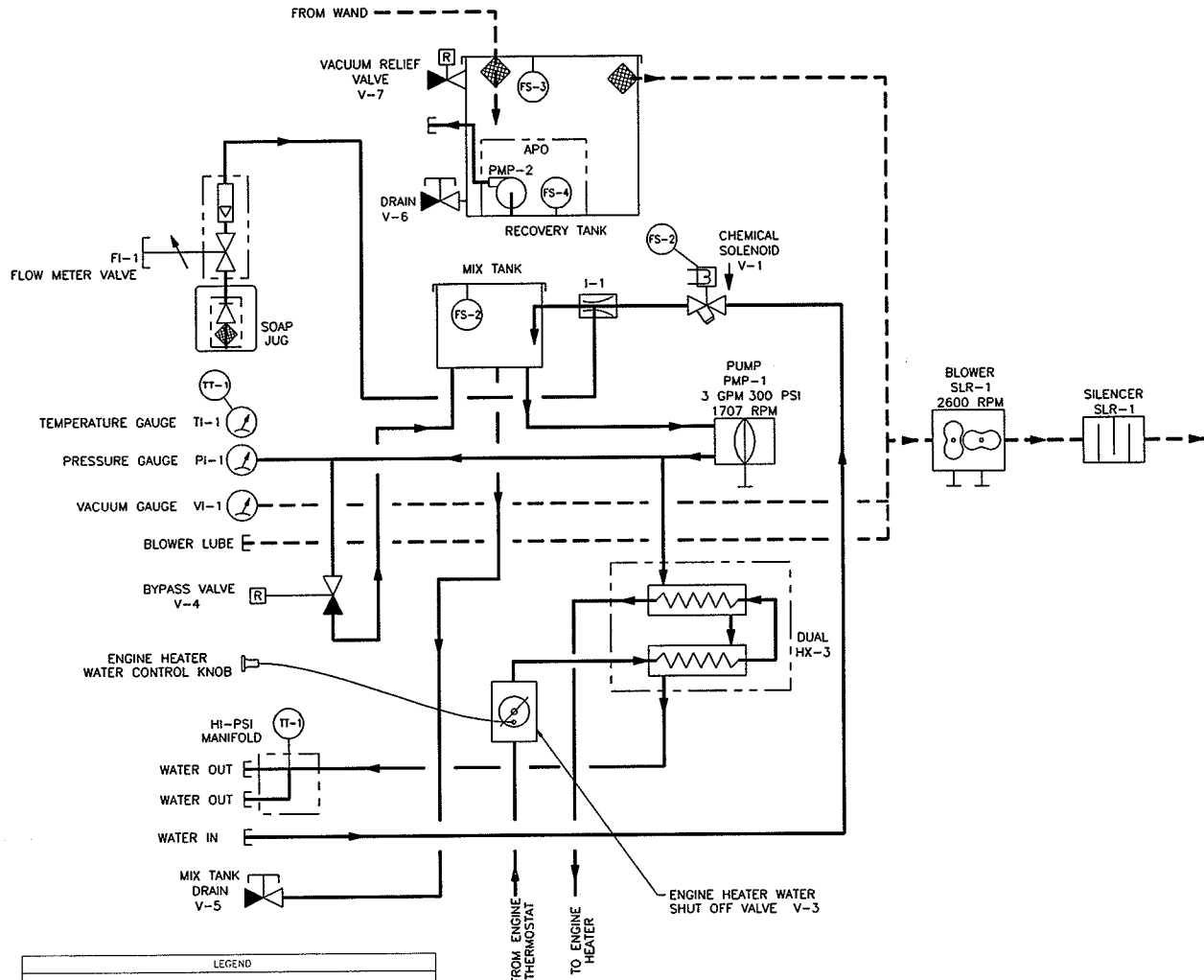

LEGEND	
→ (Solid line)	HI-PRESSURE LOW PRESSURE DRAIN
- - - (Dashed line)	ENGINE EXHAUST BLOWER EXHAUST
	COMBUSTION ENGINE
	CENTRIFUGAL PUMP
	DIAPHRAGM PUMP
	BLOWER
	SILENCER
	SOLENOID VALVE NORMALLY CLOSED WITH STRAINER
	SOLENOID VALVE NORMALLY OPEN WITH STRAINER
	RELIEF VALVE
	MANUAL VALVE
	ORIFICE
	HEAT EXCHANGER
	GAUGE
	FILTER
	VENTURI OR INJECTOR
	FLOW METER
	ADJUSTABLE METERING VALVE
	CHECK VALVE
	TRANSDUCER OR SWITCH
	Y-STRAINER

Figure 5-2: Proportioner Diagram

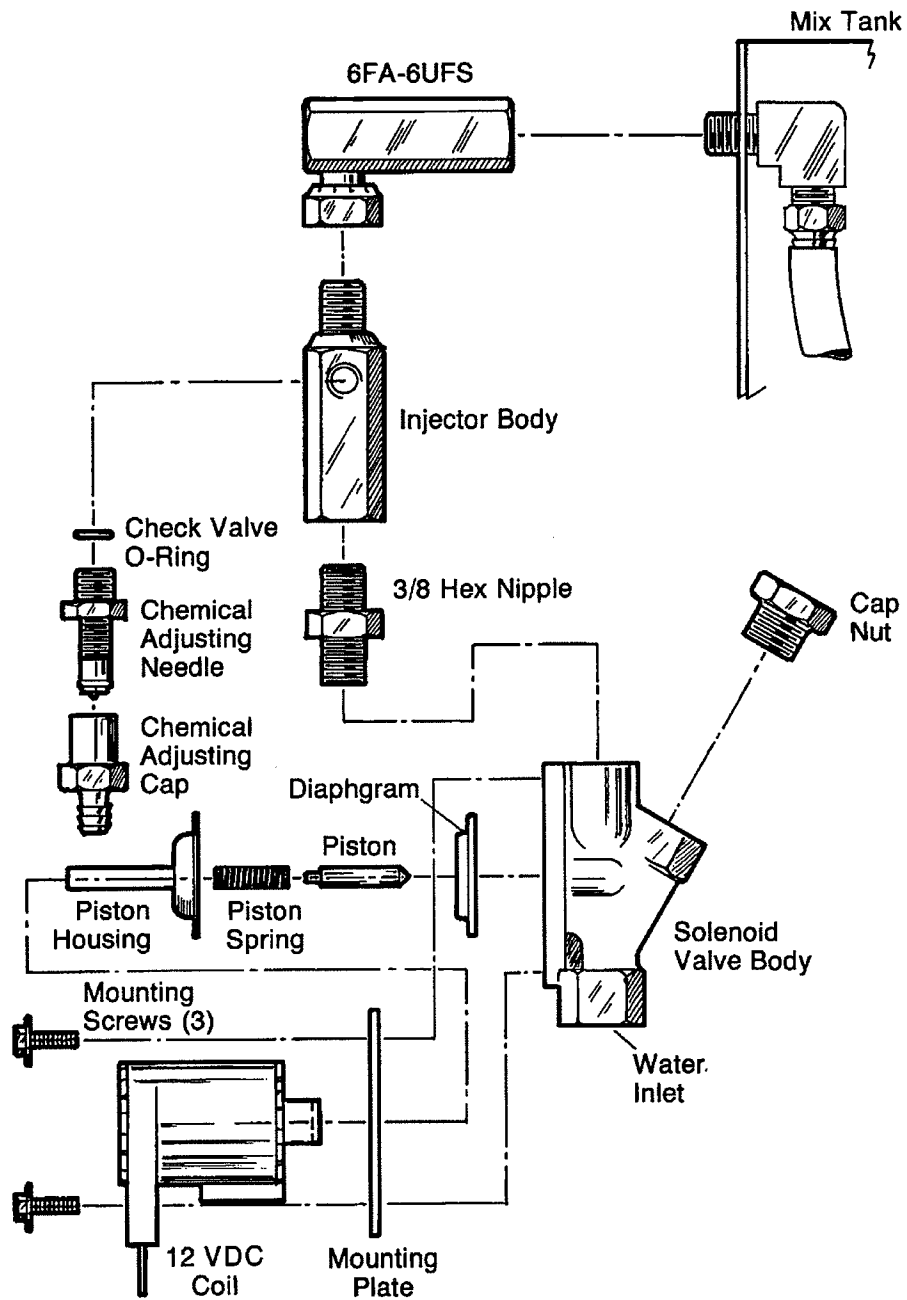

---

# *Pump Maintenance*

*CDS 4.2 / 4.7*

*Section 6-1*

## **DAILY**

Check the oil level and the condition of the oil. The oil level should be 3/4 inch from the top of the fill port to the line on the oil fill plug's dipstick (63).

Use a 5-30 weight synthetic motor.

◆ CAUTION ◆

If you are losing oil but don't see any external leakage, or if the oil becomes discolored and contaminated, one of the diaphragms (17) may be damaged. Refer to the Service Section.

Do not operate the pump with a damaged diaphragm!

◆ CAUTION ◆

Do not leave contaminated oil in the pump housing or leave the housing empty. Remove contaminated oil as soon as discovered and replace it with clean oil.

## **PERIODICALLY**

Change the oil after the first 100 hours of operation, and every 400 operating hours thereafter. When changing, remove the drain plug (60) at the bottom of the pump so all oil and accumulated sediment will drain out.

◆ CAUTION ◆

Do not turn the drive shaft while the oil reservoir is empty.

◆ CAUTION ◆

Protect the pump from freezing.

---

# *Service of Wet End*

*CDS 4.2 / 4.7*

*Section 6-3*

**T**his section explains how to disassemble and inspect all easily-serviceable parts of the pump. Repair procedures for the hydraulic end (oil reservoir) of the pump are included in a later section of the manual.

◆ CAUTION ◆

**Do not disassemble the hydraulic end unless you are a skilled mechanic. For assistance, contact HydraMaster (206-775-7275) or the distributor in your area.**

## **1. Remove Manifold (3) and Valve Plate (12)**

- a. Remove all eight bolts (1) around the manifold.
- b. Remove the manifold (3) and valve plate (12).
- c. Inspect the manifold for warping or wear around the inlet and outlet ports. If wear is excessive, replace the manifold.

To check if the manifold is warped, remove the O-rings (4) and place a straightedge across it. A warped manifold (.003 inches or greater) should be replaced.

- d. Inspect the valve plate in the same manner as the manifold.

## **2. Inspect Valves (5-11)**

The three inlet and three outlet valve assemblies are identical (but face in the opposite direction). Inspect each valve as follows:

- a. Check the spring retainer (10), and replace if worn.

- b. Check the valve spring (8). If it is shorter than a new spring, replace it (don't just stretch the old spring).
- c. Check the valve poppet (7). If worn excessively, replace it.
- d. Remove the valve seat (6).

Inspect the valve seat for wear, and replace it if necessary. A new O-ring (5) should be installed.

- e. Check the dampening washer (11), and replace if worn.
- f. Reinstall the valve assemblies:
  - ▷ Clean the valve ports and shoulders with emery cloth, and lubricate them with lubricating gel or petroleum jelly.
  - ▷ Install the O-Ring (5) on the valve seat (6).
  - ▷ **Inlet (3 upper valves in the illustration below).** Insert the spring retainer (10) into the valve plate, then insert the spring, valve, Tetra seal, valve seat, and dampening washer (8,7,9,6,11). A flat O-Ring [Tetra seal] (5) goes between the retainer and seat.
  - ▷ **Outlet (3 upper valves in the illustration).** Insert the dampening washer, valve and spring, then the retainer. Install the flat O-ring between the retainer and seat.

### 3. Inspect and Replace Diaphragms (17)

- a. Remove the two cap screws (14) from the valve plate (12).
- b. Lift a diaphragm by one edge and turn the pump shaft until the diaphragm moves up to "top dead center." This will expose machined cross-holes in the plumber shaft behind the diaphragms.



- c. Insert a hex wrench through one of the machined cross holes, to hold the diaphragm up. (Don't remove the tool until the new diaphragm is installed in step "g" below.)
  - d. Unscrew the diaphragm. Use a 5/16 in. open end wrench, and turn counterclockwise.
  - e. Inspect the diaphragm carefully. A ruptured diaphragm generally indicates a pumping system problem, and replacing only the diaphragm will not solve the larger problem. Inspect the diaphragm for the following:
    - ▷ **Small Puncture.** Usually caused by a sharp foreign object in the fluid, or by an ice particle.
    - ▷ **Diaphragm pulled away** from the side. Usually caused by fluid being frozen in the pump, or by over-pressurization of the pump.
    - ▷ **Diaphragm becoming stiff** and losing flexibility. Usually caused by pumping a fluid which is incompatible with the diaphragm material.
    - ▷ **Diaphragm edge chewed away.** Usually caused by over-pressurizing the system.
  - f. Clean away any spilled oil. Apply Loctite #242 Threadlocker to the screw of the new diaphragm (or the old one, as appropriate).
  - g. Install the diaphragm and tighten to 10 in-lbs.
  - h. Repeat the above inspection procedure (and replacement, if necessary) with the other two diaphragms.
- 4. Flush Contaminant from Hydraulic End  
(only if a diaphragm has ruptured)**
- a. With the valve plate, manifold, and diaphragm cushion plate still removed (see above), remove the oil drain cap (63) and allow all oil and

contaminant to drain out.

- b. Fill the reservoir with kerosene or solvent. Manually turn the pump shaft to circulate the kerosene. Drain.

◆ CAUTION ◆

**If you have EPDM diaphragms, or if food grade oil is in the reservoir, do not use kerosene or solvents. Instead, flush with the same lubricant that is in the reservoir. Pumps with EPDM diaphragms have "E" as the 7th digit of the Model Number.**

- c. Repeat the flushing procedure (step "B" above).
- d. Fill the reservoir with fresh oil. Manually turn the pump shaft to circulate the oil. And drain once again.
- e. Refill the reservoir. If the oil appears milky, there is still contaminate in the reservoir. Repeat the flushing procedure until the oil appears clean.

### 5. Prime the Hydraulic Cells

- a. With the pump **horizontal**, fill the reservoir with the appropriate Hydra oil for the application.
- b. All air in the oil within the hydraulic cell (behind the diaphragms) must be forced out by turning the shaft (and thus pumping the piston). A shaft rotator is included in the Wanner Tool Kit.

Turn the shaft until a **bubble-free** flow of oil comes from behind all the diaphragms. Watch the oil level in the reservoir. If it gets too low during priming, air will be drawn into the pistons (inside the Hydraulic end). This will cause the pump to run rough, and you will have to start over again with priming the hydraulic cells.

- c. Wipe excess oil from the diaphragm plate and diaphragms.

### **6. Reinstall Valve Plate (12) and Manifold (3)**

- a. Reinstall the valve plate (12), with the valve assemblies installed as outlined above, onto the diaphragm plate (18).
- b. Reinstall the O-rings (4) on the rear side of the manifold. Use petroleum jelly or lubricating gel to hold them in place.
- c. Reinstall the manifold onto the valve plate.
- d. Insert all bolts (1) around the edge of the manifold, and alternately tighten opposite bolts until all are secure. Torque to 15 ft-lbs.
- e. Recheck all bolts for tightness.

---

# *Service of Hydraulic End*

*CDS 4.2 / 4.7*

*Section 6-8*

**T**his section explains how to disassemble and inspect the hydraulic end (oil reservoir) of the pump.

◆ CAUTION ◆

**Do not disassemble the hydraulic end unless you are a skilled mechanic. For assistance, contact HydraMaster (206-775-7275) or the distributor in your area.**

Depending on the repair you are attempting, you may or may not have to remove the motor from a direct-drive pump/motor unit.

Internal piston components (21 - 27) can be serviced without removing the motor or crankshaft. The motor and crankshaft must be removed to service the connecting rod (59), piston housing (20), crankshaft (57), front bearing (68), back bearing (55), or seal (54).

## **TO SERVICE PISTONS WITHOUT REMOVING MOTOR OR CRANKSHAFT**

### **1. Disassemble Pistons**

With the manifold, valve plate, diaphragm cushion, diaphragm plate, and diaphragm removed, and the oil drained from the pump (see the basic Service Section):

- a. Remove the snap ring (27) from one of the pistons, using a standard snap-ring pliers.
- b. Pull out the valve plunger (24). This also removes the washer (26) and

spring (35).

- c. Insert a hook through the center hole of the valve cylinder (22), and pull the cylinder out of the piston. Be careful not to damage the piston.
- d. Inspect all parts, and replace the O-ring and any other parts which are worn or may be damaged.
- e. Repeat steps "a" through "d" for the remaining pistons.

## **2. Reassemble Pistons**

- a. Tip the pump so the pistons are vertical.
- b. Drop a ball (21) into the opening in the bottom of the piston.
- c. Insert a valve plunger (24) into a valve cylinder (22). Slide a spring (25) over the plunger, inside the valve cylinder.
- d. Slide the assembled valve cylinder, plunger, and spring (22-25) into the piston (20).
- e. Insert a washer (26) over the plunger.
- f. Insert a snap ring (27) into the piston. Use the snap-ring pliers.
- g. Repeat the above procedure for the other two pistons.

## **TO SERVICE THE REMAINDER OF THE HYDRAULIC END**

### **1. Remove Pump Housing**

- a. Remove the manifold, valve plate, diaphragm cushion, and diaphragms, as outlined in the basic Service Section.
- b. Drain the oil from the pump housing by removing the drain plug (60).

- c. Stand the pump on end, with the drive shaft up.
- d. Remove the bolts (50) that secure the back cover (52) to the housing (78). Use a 3/8 in. socket wrench. Save the O-rings (51).
- e. Remove the cover and the cover O-ring (53).
- f. Remove the crankshaft (57) by pulling it through the connecting rods (59).

## **2. Remove and Replace Pistons**

To remove the pistons (20), first remove the connecting rod (59) and pin (58) by pressing the pin through the connecting rod.

Reverse the process to reinstall the pistons.

Refer to Step 5 and 6 below to replace the diaphragm and reassemble the pump.

## **3. Reassemble Housing and Casting**

**NOTE: Inspect the shaft seal (54) before continuing. If it looks damaged in any way, replace it. Refer to "Replace Shaft Seal" below.**

- a. Stand the pump on end.
- b. With the pistons and connecting rods in place, reinstall the crankshaft by threading it through the connecting rods.
- c. Reinstall the back cover, cover O-ring, and bolts (with their O-rings).

## **4. Replace Shaft Seal**

- a. Press the back bearing (55) and seal (54) out of the back cover (52). Discard the seal.

- b. Apply a coating to Loctite High-Performance Pipe Sealant with Teflon, or a comparable product, to the outer surface of a new seal and the inside surface of the opening in the back cover (52) where the seal will rest.
- c. Press the new seal into the back cover.
- d. Inspect the bearing (55). If pitted or damaged, replace it.
- e. Apply a coating of Loctite Rc-609 retaining Compound or comparable product to the outer surface of the bearing. Press the bearing into the back cover until it rests on the shoulder. The shield on the bearing **must** face away from the back cover.

## **5. Reinstall Diaphragms**

- a. Screw the plunger puller (from the Tool Kit or Repair Kit) into the plunger (24). Pull out to expose the cross holes in the plunger. Rotate the shaft until the piston is at top dead center.
- b. Insert a diaphragm hex wrench (from the Tool Kit), or similar dowel-type object, through the plunger holes to hold the plunger away from the diaphragm place (18), and to keep the plunger from turning when the diaphragm is being installed.
- c. Apply a small amount of Loctite #242 to the threads of the diaphragm screw (be sure the threads are clean).
- d. Set the diaphragm (17) on the plunger (24), ridge-side out. Screw the diaphragm onto the plunger.
- e. Hold the diaphragm hex wrench, and tighten the diaphragm to 10 in.-lbs of torque.
- f. Repeat the above procedure for the plungers and diaphragms of the other two cylinders.
- g. Fill the reservoir with fresh oil and prime the pump, as outlined in the

basic Service Section.

## **6. Reassemble Pump**

Reassemble the pump as outlined in the basic Service Section.



---

# *Pump Troubleshooting*

*CDS 4.2 / 4.7*

*Section 6-13*

## Cavitation

Inadequate fluid supply because of:

- Inlet line collapsed or clogged
- Air leak in inlet line
- Worn or damaged inlet hose

Fluid too hot for inlet suction piping system.

Air entrained in fluid piping system.

Aeration and turbulence in supply tank.

Inlet suction vacuum too high.

Symptoms of Cavitation:

- Excessive pump valve noise
- Premature failure of spring or retainer (8, 10)
- Volume or pressure drop
- Rough-running pump.

## Drop in Volume or Pressure

Air leak in suction piping.

Clogged suction line or suction strainer.

Suction line inlet above fluid level in tank.

Inadequate fluid supply.

Pump not operating at proper RPM.

Worn pump valve parts.

Foreign material in inlet or outlet valves.

Loss of oil prime in cells because of low oil level.

Ruptured diaphragm.

Cavitation.

Warped manifold from over-pressurized system.

O-rings forced out of their grooves from over-pressurization.

Air leak in suction line strainer or gasket.

## Water Pulsations

- Foreign object lodged in pump valve.
- Loss of prime in hydraulic cells because of low oil level.
- Air in suction line.
- Valve spring broken.
- Cavitation.
- Aeration or turbulence in supply tank.

## Valve Wear

- Normal wear.

## Loss of Oil

- External seepage.
- Rupture of diaphragm.
- Frozen pump.
- Worn shaft seal.
- Oil drain piping or fill cap loose.
- Valve plate and manifold bolts loose.

## Premature Failure of Valve Spring or Retainer

- Cavitation.
- Foreign object in the pump.
- Pump running too fast.
- Spring/retainer material incompatible with fluid being pumped.
- Excessive inlet pressure.

Figure 6-1

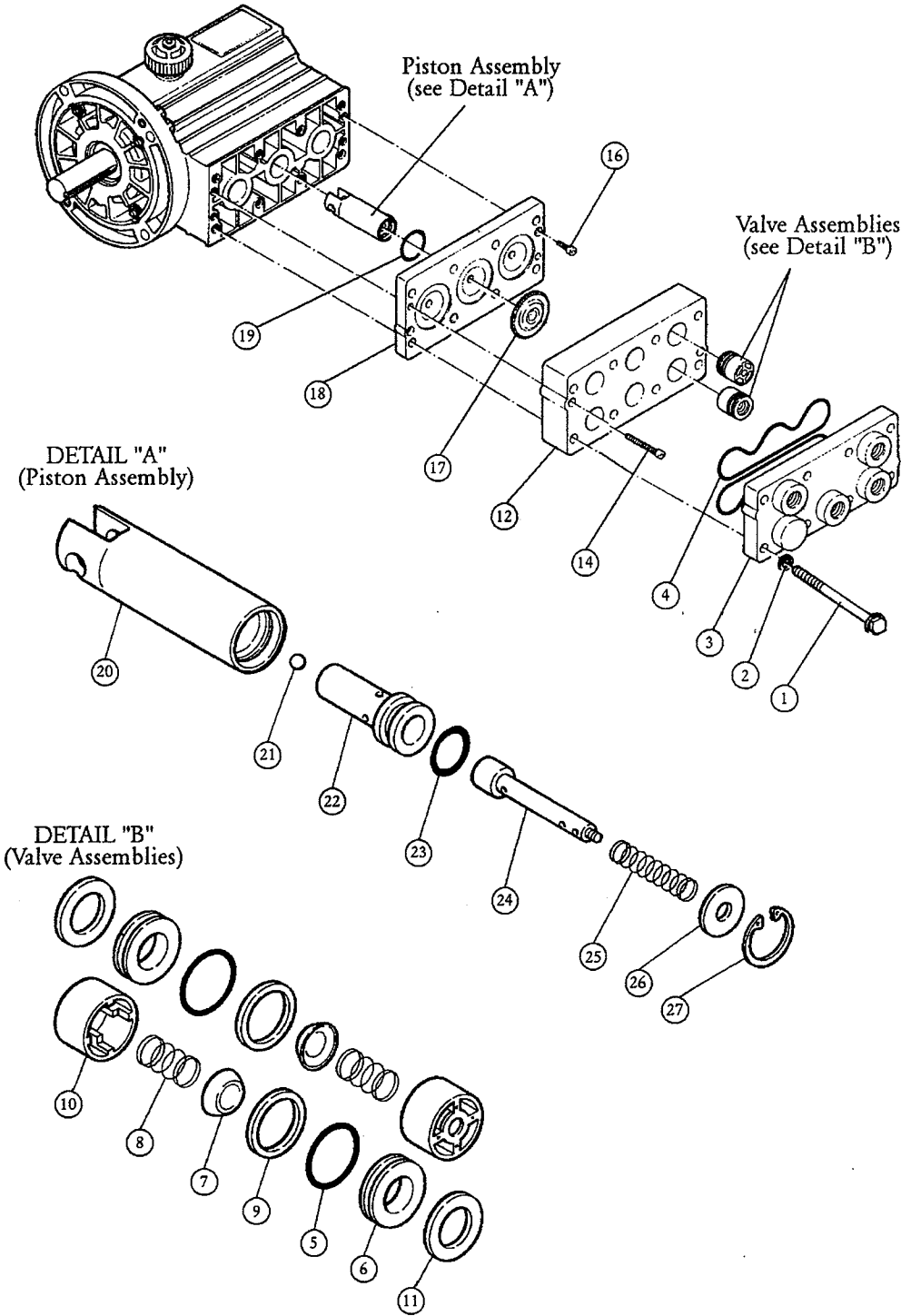

## PARTS LIST

REF. NO.	PART NO.	DESCRIPTION	QTY. PER PUMP
1	D03-024-2010	Bolt, 3" hex-head	8
2	C22-014-2000	Washer, 5/16"	8
3	D03-004-1010	Manifold, brass, NPT	1
4	D03-073-2110	O-ring, manifold, Buna	2
5	C24-009-2110	O-ring, valve seat, Buna	6
6	D03-020-1002	Valve Seat, 17-4 SST	6
7	D03-021-1002	Valve, 17-7 SST	6
8	D03-022-3114	Valve Spring, Elgiloy	6
9	D03-092-2110	Tetra Seal, Buna	6
10	D03-023-2310	Retainer, valve spring, Celcon	6
11	D03-125-2310	Washer, dampening, Celcon	6
12	D03-003-1010	Valve Plate, brass	1
14	D03-029-2010	Cap Screw, socket-head, 1"	2
16	D03-088-2010	Cap Screw, socket-head 1/2"	2
17	D03-018-1220	Diaphragm, Buna-N-XS	3
18	D03-002-1000	Diaphragm Plate	1
19	D03-075-2110	O-ring, diaphragm plate, Buna	3
20	D03-014-1004	Piston	3
21	D10-015-3010	Ball	3
22	D03-043-1000	Valve Cylinder	3
23	D03-034-2110	O-ring, valve cylinder, Buna	3
24	D03-044-1000	Valve Plunger	3
25	D03-045-3110	Spring, sleeve valve	3
26	D03-049-1000	Washer	3
27	D03-048-2210	Snap Ring	3

Figure 6-2

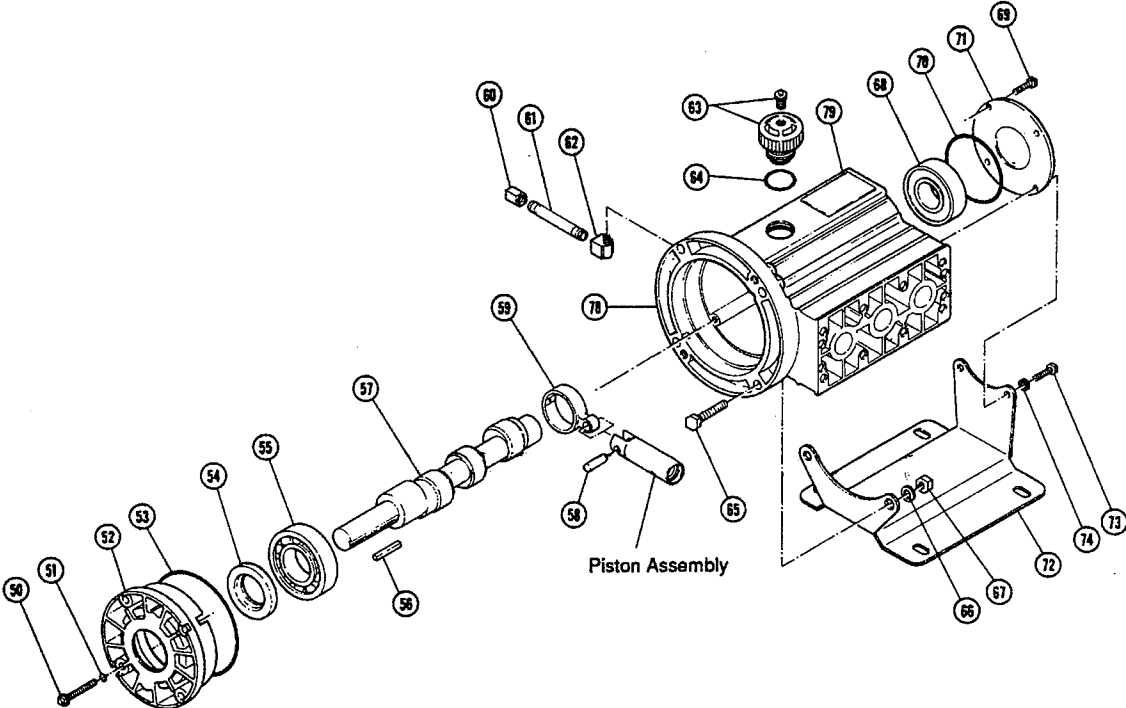

## PARTS LIST CONTINUED...

REF. NO.	PART NO.	DESCRIPTION	QTY. PER PUMP
50	D03-086-2010	Cap Screw, hex-head, with washer	4
51	D03-036-2110	O-ring, back cover screws, Buna	4
52	D03-131-1000	Back Cover	1
53	D03-037-2110	O-ring, back cover, Buna	1
54	D03-031-2110	Seal, Buna	1
55	D03-011-2910	Back Bearing	1
56	D03-085-2210	Key, shaft	1
57	D03-009-1003	Crank Shaft, shaft-driven, 3.0 GPM @ 1725 RPM	1
58	D03-133-1000	Pin	3
59	D03-132-1000	Connecting Rod	3
63	000-027-006	Cap, HydraPump w/ vent & O-ring	1
64	D10-080-2110	O-ring, oil fill, Buna	1
68	D03-010-2910	Front Bearing	1
69	D03-087-2010	Cap Screw, hex-head, 1/2"	4
70	D40-074-2110	O-ring, front cover, Buna	1
71	D03-130-1000	Front Cover	1
78	D03-001-1001	Pump Housing [D-03, M-03]	1
	M13-001-1001	Pump Housing [M-13]	1
79	D10-040-2410	Name Plate	1

# CDS Parts

CDS 4.2 / 4.7  
Section 7-1

Figure 7-1: CDS 4.2 Machine Assembly

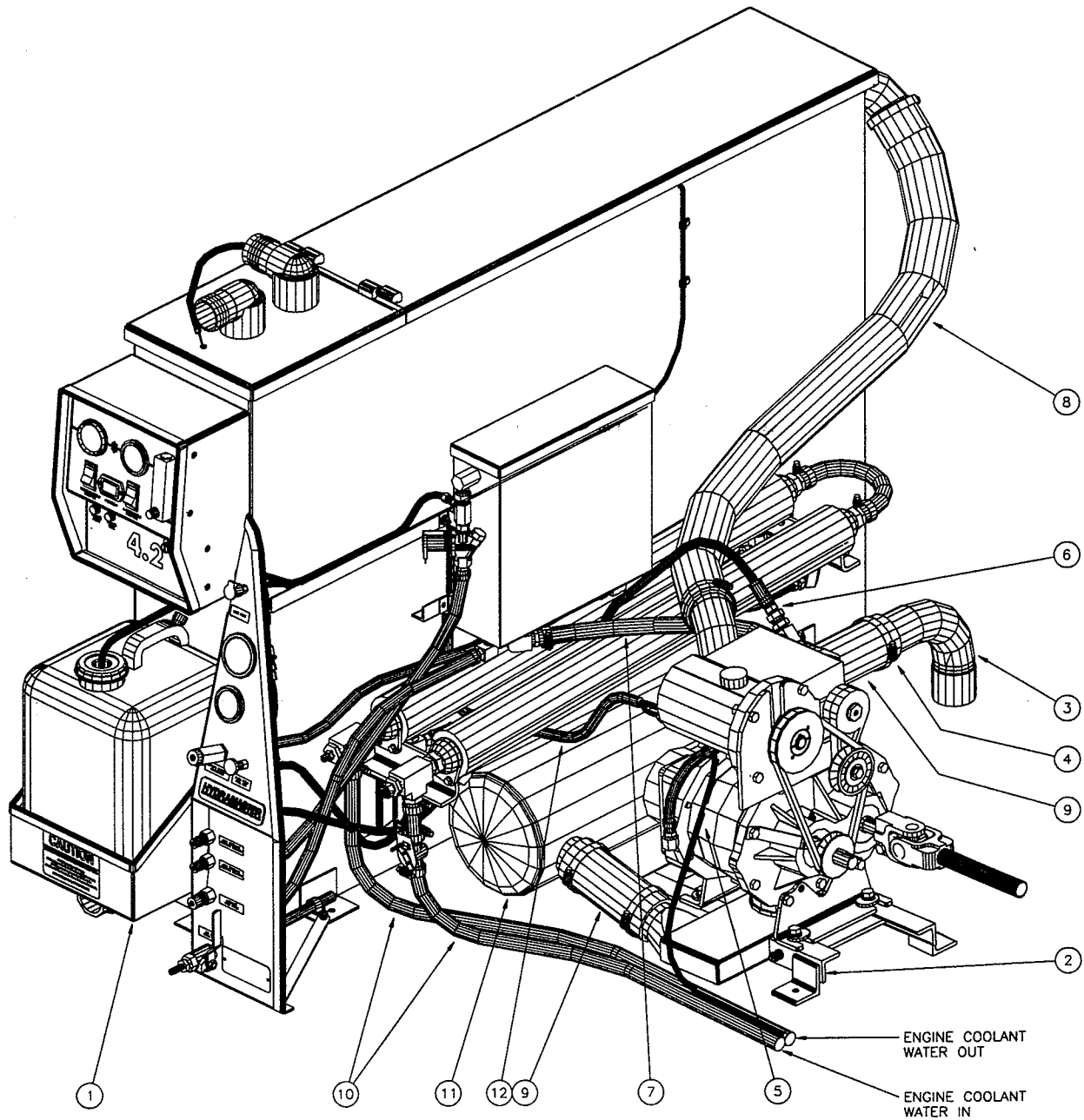
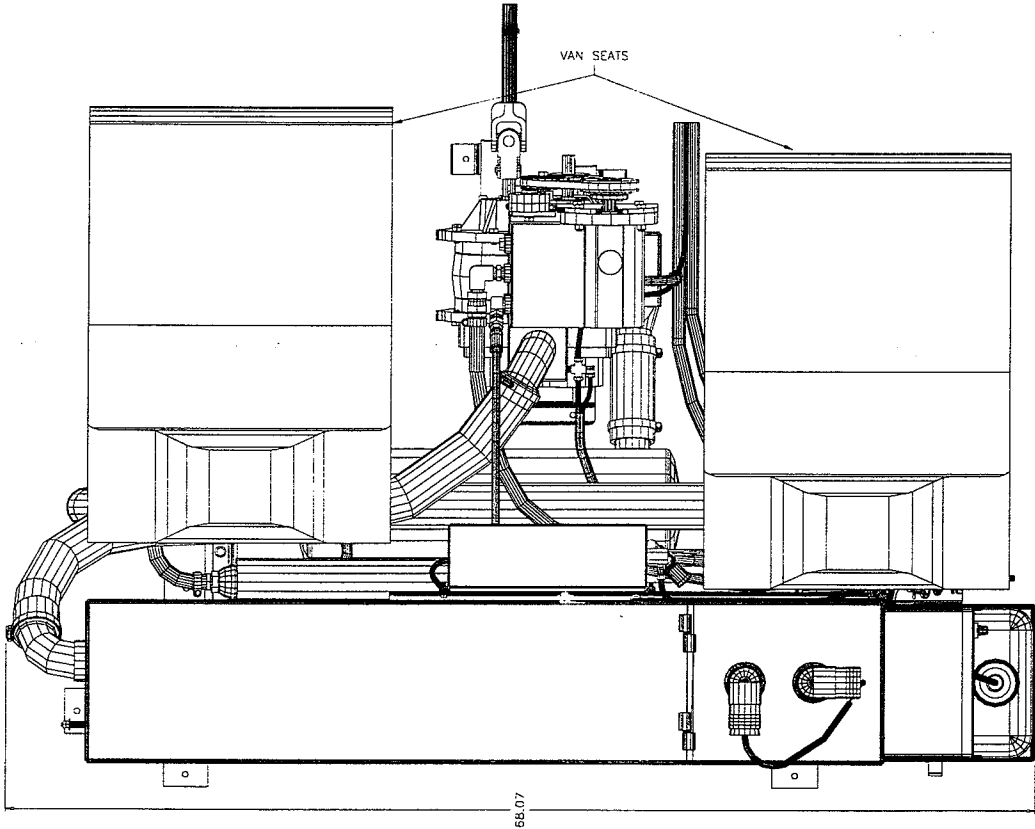
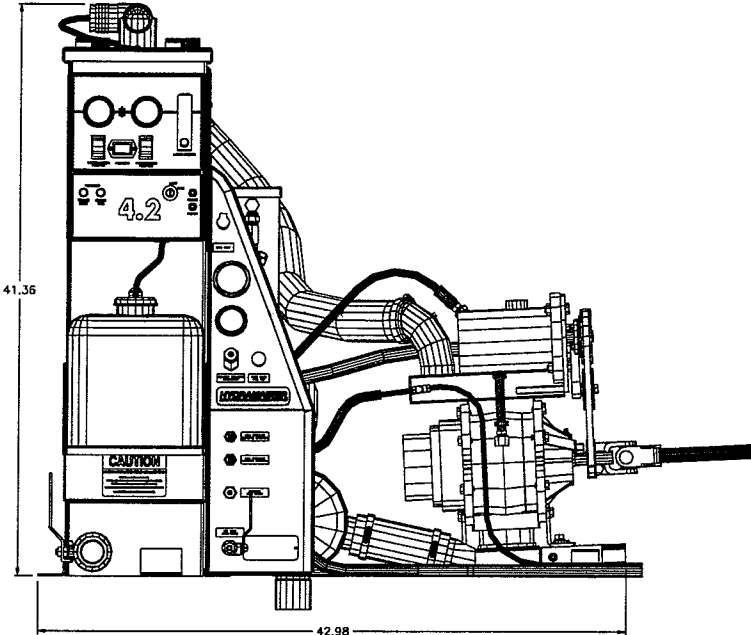

Figure 7-2





## CDS 4.2 Machine Assembly Parts List

ITEM	PART NO	DESCRIPTION	QTY
1	Figure 7-6, 7	Recovery Tank Assembly	1
2	Figure 7-11	Pump and Blower Assembly	1
3	001-004	Adapter, Silencer Exhaust	1
4	033-012	Clamp, Size 44 Hose	2
5	068-030	Hose, $\frac{5}{32}$ " Rubber Vacuum	11'
6	068-301	Hose, $\frac{3}{8}$ " x 32" Throb High Pres. Portable	1
7	068-148	Hose, $\frac{3}{4}$ " x 22" Synflex with $\frac{1}{2}$ and $\frac{3}{4}$ " Ends	1
8	068-189	Hose, $2\frac{3}{4}$ " x 4' CDS Blower to Vacuum Tank	1
9	068-162	Hose, CDS Silencer to Exhaust Adapter	2
10	068-156	Hose, CDS High Temp Heat Exchanger	2
11	093-002	Silencer Assembly, CDS Exhaust	1
12	063-008	Wire Harness Wrap, Split Seam	6'

Figure 7-3: CDS 4.7 Machine Assembly

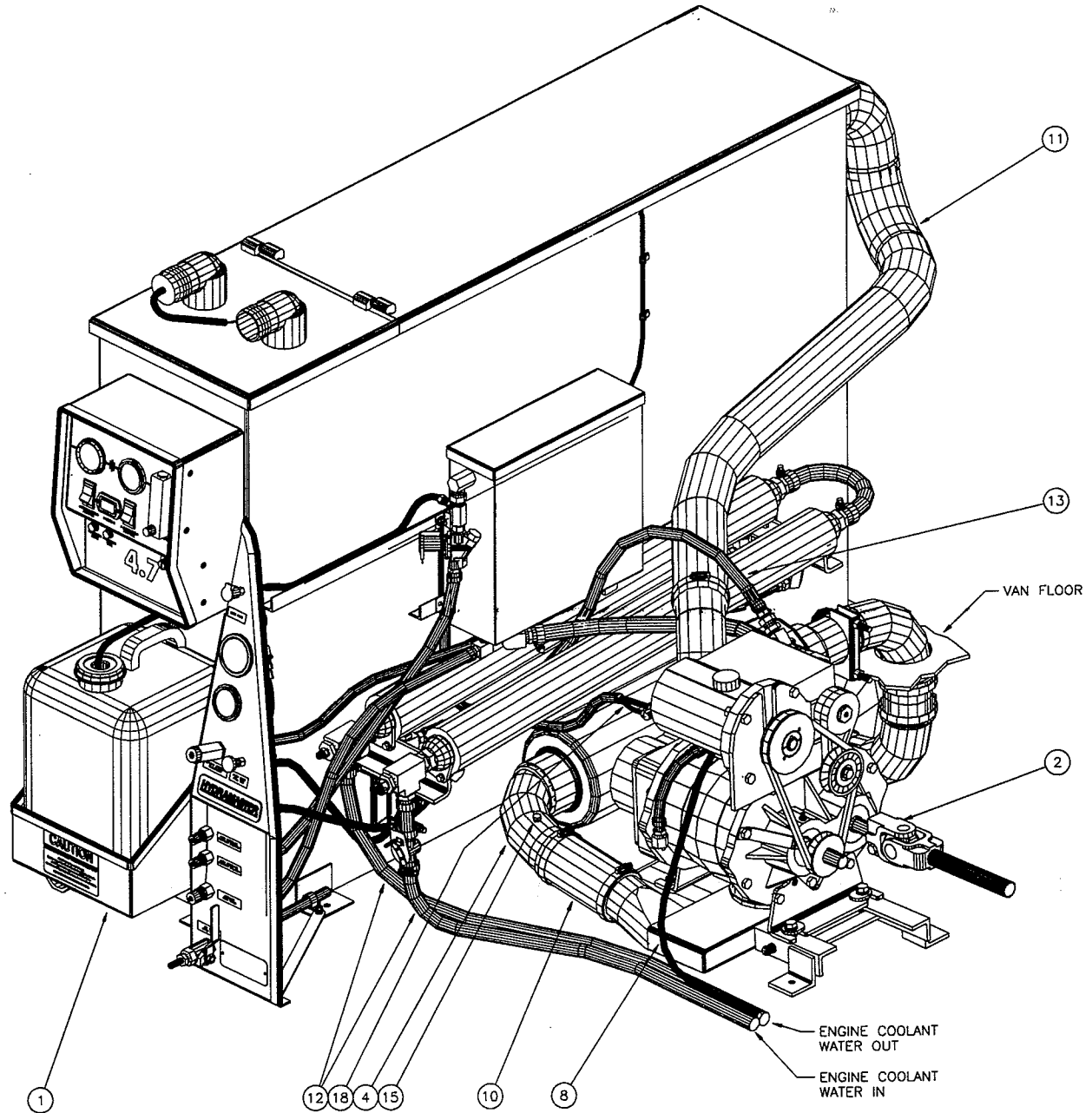

Figure 7-4

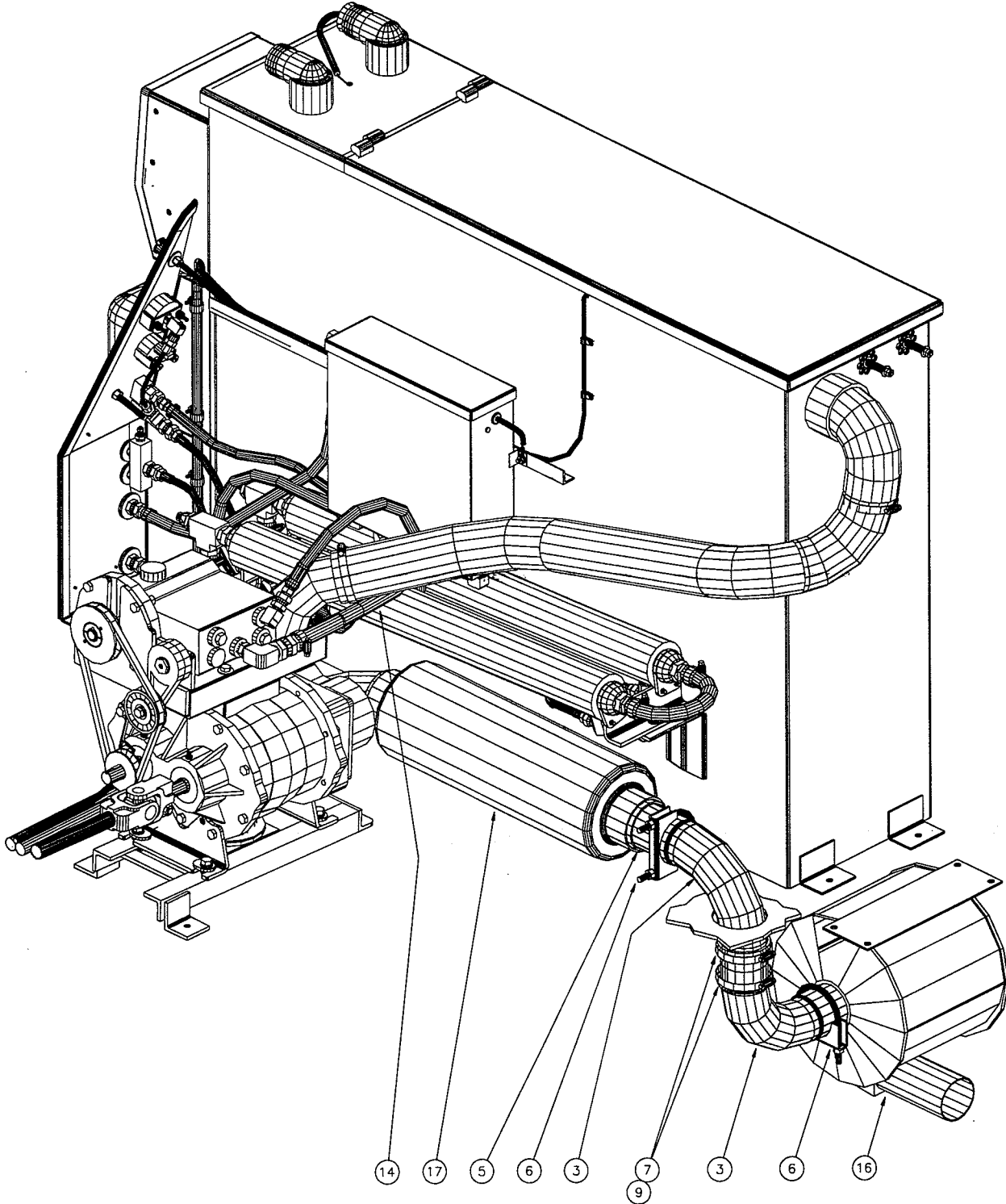
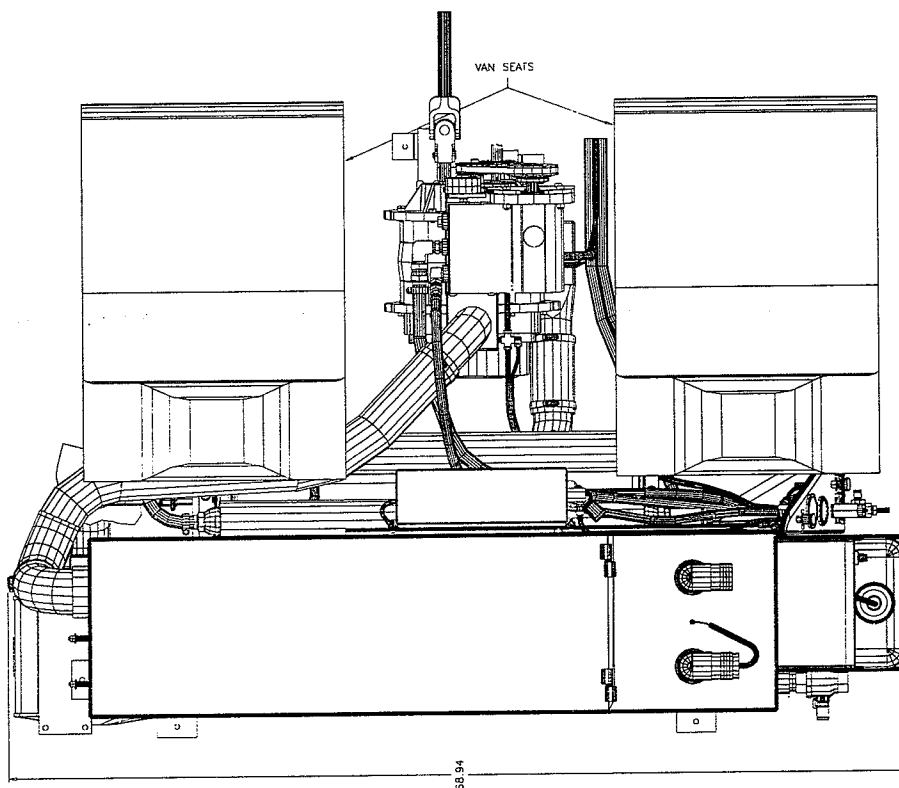
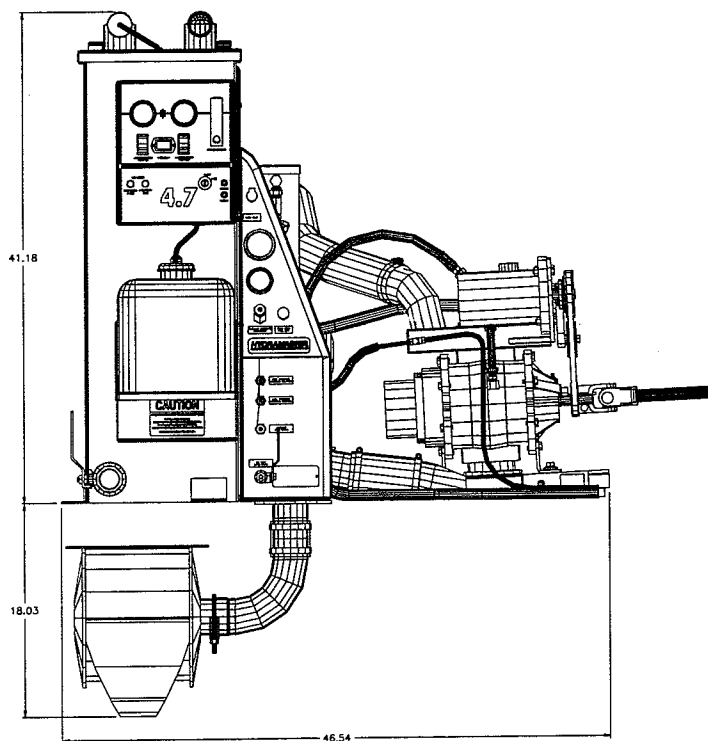

Figure 7-5



## CDS 4.7 Machine Assembly Parts List

ITEM	PART NO	DESCRIPTION	QTY
1	Figure 7-6, 7	Recovery Tank Assembly	1
2	Figure 7-12	Pump and Blower Assembly	1
3	001-006	Adapter, CDS L-Silencer Exhaust	2
4	052-334	Adapter, Vacuum Blower Inlet Fitting	1
5	052-332	Adapter, Vacuum Tank Outlet	1
6	033-034	Clamp, 3" Muffler	2
7	033-013	Clamp, Size 48 Hose	2
8	068-030	Hose, $\frac{5}{32}$ " Rubber Vacuum	11'
9	068-008	Hose, 3" Type 54 Nitrile	4"
10	068-200	Hose, CDS L-Blower Exhaust	1
11	068-202	Hose, CDS L-Blower to Vacuum Tank	1
12	068-156	Hose, CDS High Temp Heat Exchanger	2
13	068-301	Hose, $\frac{3}{8}$ " x 32" Throb High Pres. Portable	1
14	068-148	Hose, $\frac{3}{4}$ " x 22" Synflex with $\frac{1}{2}$ " and $\frac{3}{4}$ " Ends	1
15	106-001	Plug, $\frac{1}{8}$ " Brass	1
16	093-030	Silencer	1
17	093-003	Silencer, Hush Kit Muffler	1
18	063-008	Wire Harness Wrap, Split Seam	10'

## Figure 7-6: Recovery Tank Assembly

D3458 and D3459, Rev A

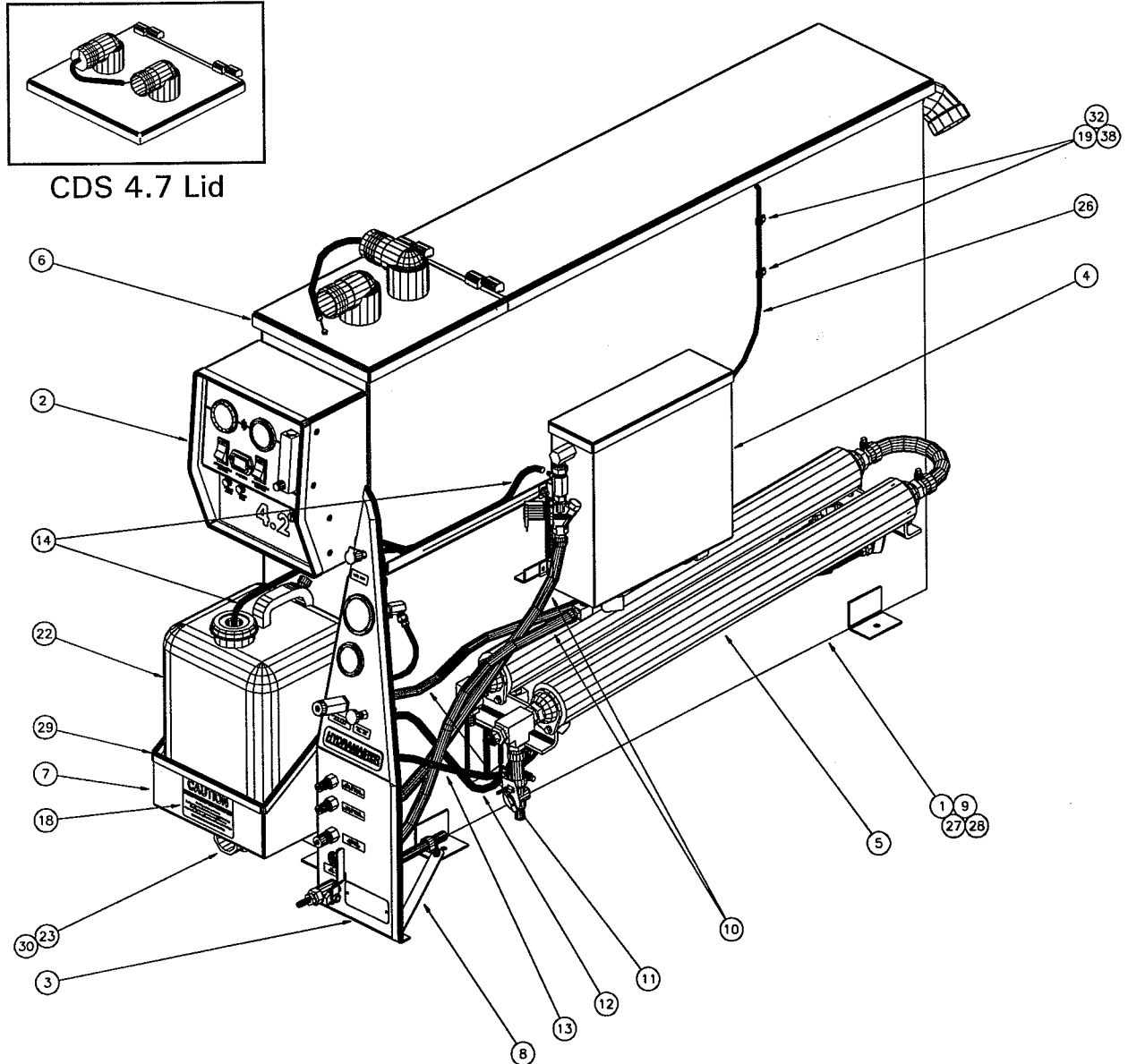
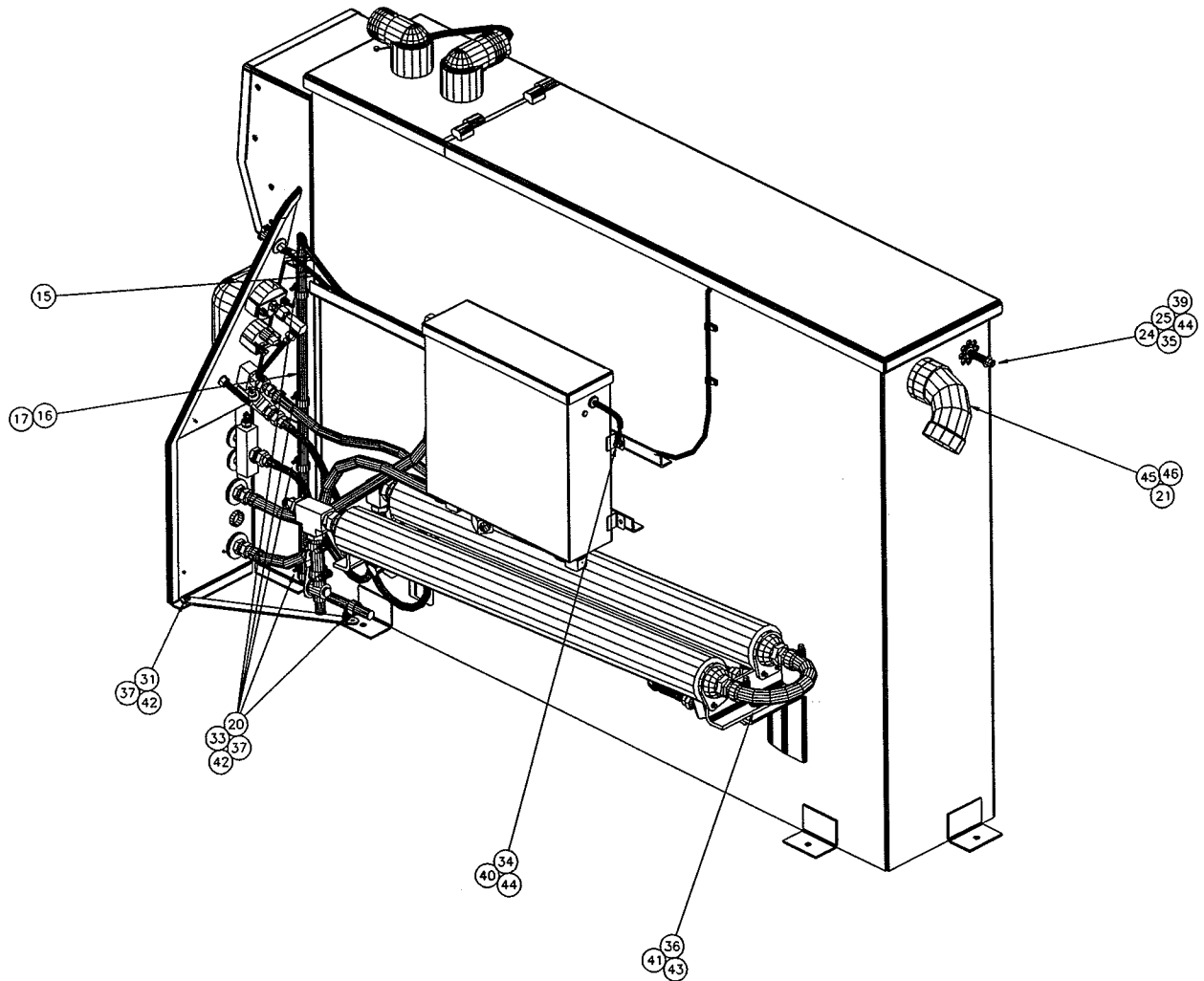
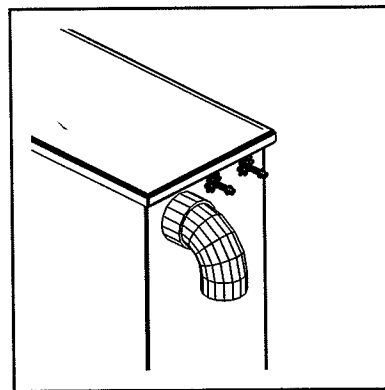
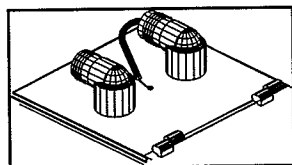

Figure 7-7  
D2458 and D3459, Rev A



CDS 4.7

CDS 4.7 Lid



## Recovery Tank Assembly Parts List

ITEM	PART NO	DESCRIPTION	QTY
1	159-014	Tank, Recovery - CDS 4.2	1
	159-031	Tank, Recovery - CDS 4.7	1
2	Figure 7-13	Dash Box Assembly	1
3	Figure 7-8	Instrument Panel Assembly	1
4	Figure 7-15	Mix Tank Assembly	1
5	Figure 7-9	Dual Heat Exchanger Assembly	1
6	Figure 7-16, 17	Lid Assembly	1
7	166-002	Tray, Chemical Soap Jug	1
8	601-013-001	CDS Instr. Panel to Vac Tank Stabilizer	1
9	105-015	Plate, Filter Bag Support - CDS 4.2	1
	105-011	Plate, Filter Bag Support - CDS 4.7	1
10	068-152	Hose, Mix Tank - Control Panel	2
11	068-150	Hose, CDS By-Pass, High Press. Reg.	1
12	068-089	Hose, 3/8" x 24" Teflon	1
13	068-094	Hose, 3/8" x 16" Teflon	1
14	068-025	Hose, 1/4" Clear	2 1/2 Ft
15	068-030	Hose, 5/32" Rubber / Vacuum	4 1/8 Ft
16	063-007	Harness, CDS Wire - Primary	1
17	063-008	Wire Harness Wrap, Split Seam	3 Ft
18	081-070	Label, Small Caution	1
19	033-021	Clamp, 1/4 Nylon Hose	3
20	033-023	Clamp, 3/4 Nylon Hose	5
21	049-007	Filter, s/s Vacuum Pump Blower - CDS 4.2	1
	049-013	Filter, s/s Vacuum Pump Blower - CDS 4.7	1
22	159-016	Jug, 5 Gallon Plastic Chemical	1
23	052-182	Nipple, 1 1/2" Close - Galvanized Steel	1
24	105-005	Plate, Vacuum Relief	1
25	155-002	Spring, s/s Vacuum Relief Valve	1
26	157-0012	Switch, Tethrd Float Hvy-Duty Liquid Level	1
27	131-027	Trimlok, Brow Trim	3/8"
28	131-028	Gasket, Trimlok - Recovery Tank	3/4"
29	131-003	Gasket, CDS Trim	3/4"
30	169-022	Valve, 1 1/2" Full Port Brass Dump	1
31	143-114	Screw, 10 - 24 x 1/2" FHM Phillips s/s	1



ITEM	PART NO	DESCRIPTION	QTY
32	143-132	Screw, 10 - 24 x 3/4" HHC s/s	2
33	143-064	Screw, 10 - 24 x 1" Flat Hd Mach - Phillips	5
34	143-115	Screw, 1/4 - 20 x 3/4" HHCS s/s	2
35	143-009	Screw, 1/4 - 20 x 2 1/2" HHC s/s	1
36	143-143	Screw, 5/16 - 18 x 1" HHC s/s	2
37	094-004	Nut, 10 - 24 Hex	11
38	094-034	Nut, 10 - 24 s/s Nylock	2
39	094-010	Nut, 1/4 - 20 s/s Hex	2
40	094-007	Nut, 1/4 - 20 Whiz	2
41	094-023	Nut, 5/16 - 18 Whiz	2
42	174-015	Washer, #10 Outside Star	11
43	174-002	Washer, 1/4 Flat	2
44	174-003	Washer, 1/4 s/s Flat	4
45	052-223	Elbow, 2" F Slip x M Slip ABS - CDS 4.2	1
	052-360	Adapter, 3" FPT x 3" M Slip ABS - CDS 4.7	1
46	052-219	Adapter, 2" NPT x 2" F Slip ABS - CDS 4.2	1
	052-361	Elbow, 3" F Slip x 3" M Slip 90 ABS - CDS 4.7	1

## Figure 7-8: Instrument Panel Assembly

D2878, Rev B

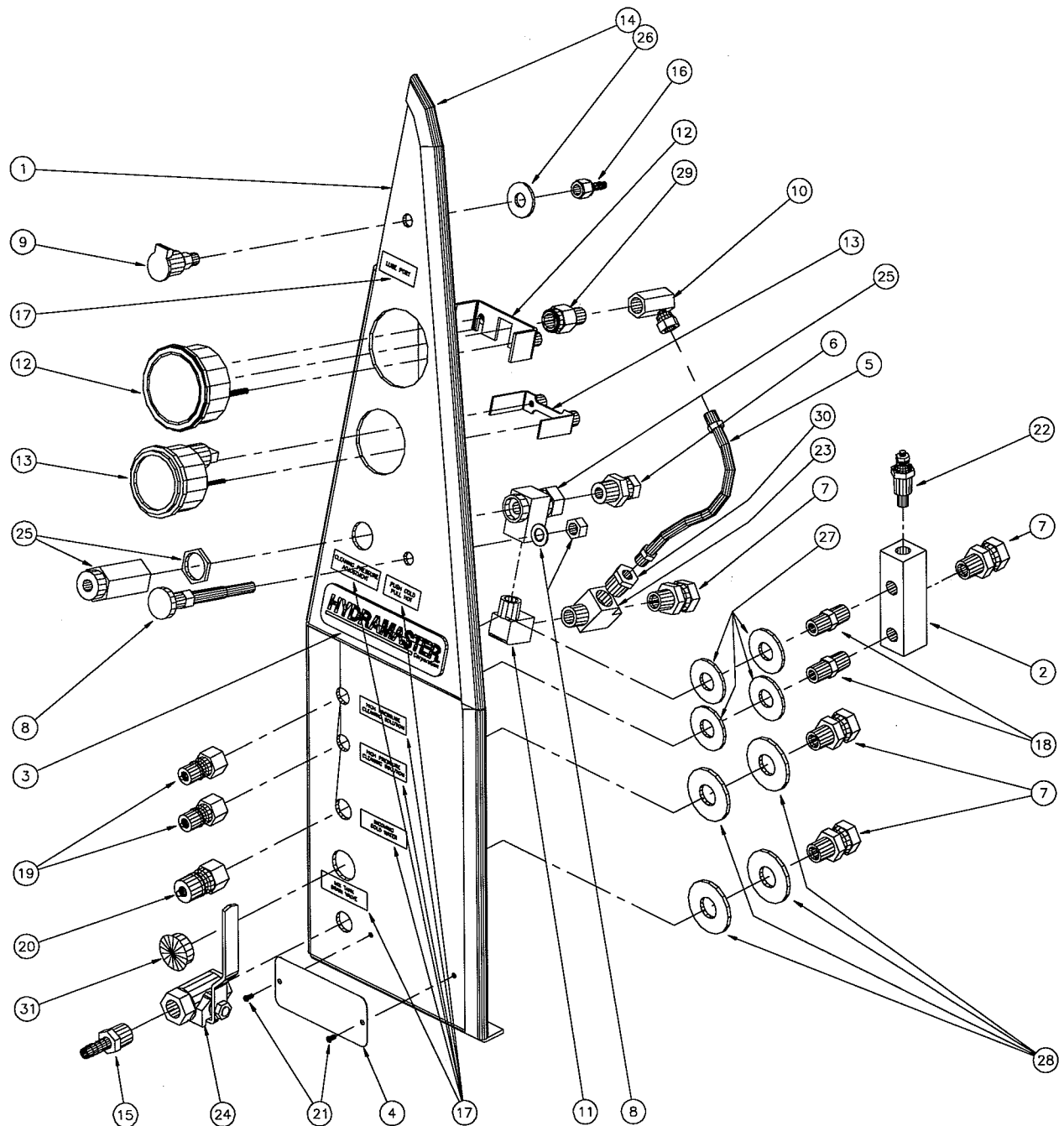

## Instrument Panel Assembly Parts List

ITEM	PART NO	DESCRIPTION	QTY
1	100-007	Panel, CDS Control	1
2	090-008	Manifold, High Press. Brass	1
3	105-020	Plate, HM Cast Name	1
4	105-012	Plate, Machine Serial ID	1
5	068-380	Hose, $\frac{3}{16}$ " x $6\frac{1}{2}$ " Teflon	1
6	052-016	6M-4UFS	1
7	052-019	6M-6UFS	4
8	025-002	Cable, Choke (3 Feet)	1
9	052-272	Cup, Gravity Feed Oil Blower Lub. Port	1
10	052-010	4FA-2UFS	1
11	052-086	Elbow, $\frac{3}{8}$ " Brass Street	1
12	074-003	Gauge, High PSI (1-1000)	1
13	074-006	Gauge, Vacuum	1
14	131-003	Gasket, CDS Trim	$\frac{3}{4}$ "
15	052-104	Insert, #66	1
16	052-096	Insert, #F23	1
17	081-072	Label, CDS Control Panel - Set	1
18	052-071	Nipple, $\frac{1}{4}$ Brass hex	2
19	052-050	Quick Connect, 440 Male w/ Viton - Standard	2
20	052-052	Quick Connect, 660 Male w/ Viton - Standard	1
21	140-015	Rivet, $\frac{1}{8}$ " x $\frac{1}{4}$ " Aluminum Pop	2
22	149-002	Sender, s/w Temp - $\frac{1}{4}$ " Threads	1
23	052-023	Tee, $\frac{3}{8}$ " Male Street - Brass	1
24	169-064	Valve, $\frac{3}{8}$ " Full Port Ball	1
25	169-101	Valve, By-Pass	1
26	174-005	Washer, $\frac{3}{8}$ Flat	1
27	174-040	Washer, $\frac{9}{16}$ ID Flat	4
28	174-008	Washer, $\frac{5}{8}$ Flat	4
29	135-052	Regulator, High PSI Snubber	1
30	052-060	Bushing, $\frac{3}{8}$ M x $\frac{1}{8}$ F Brass	1
31	106-029	Plug, 1" Nylon Hole Plug x $\frac{1}{2}$ " Deep	1

**Figure 7-9: Dual Heat Exchanger Assembly**

D2976, Rev A

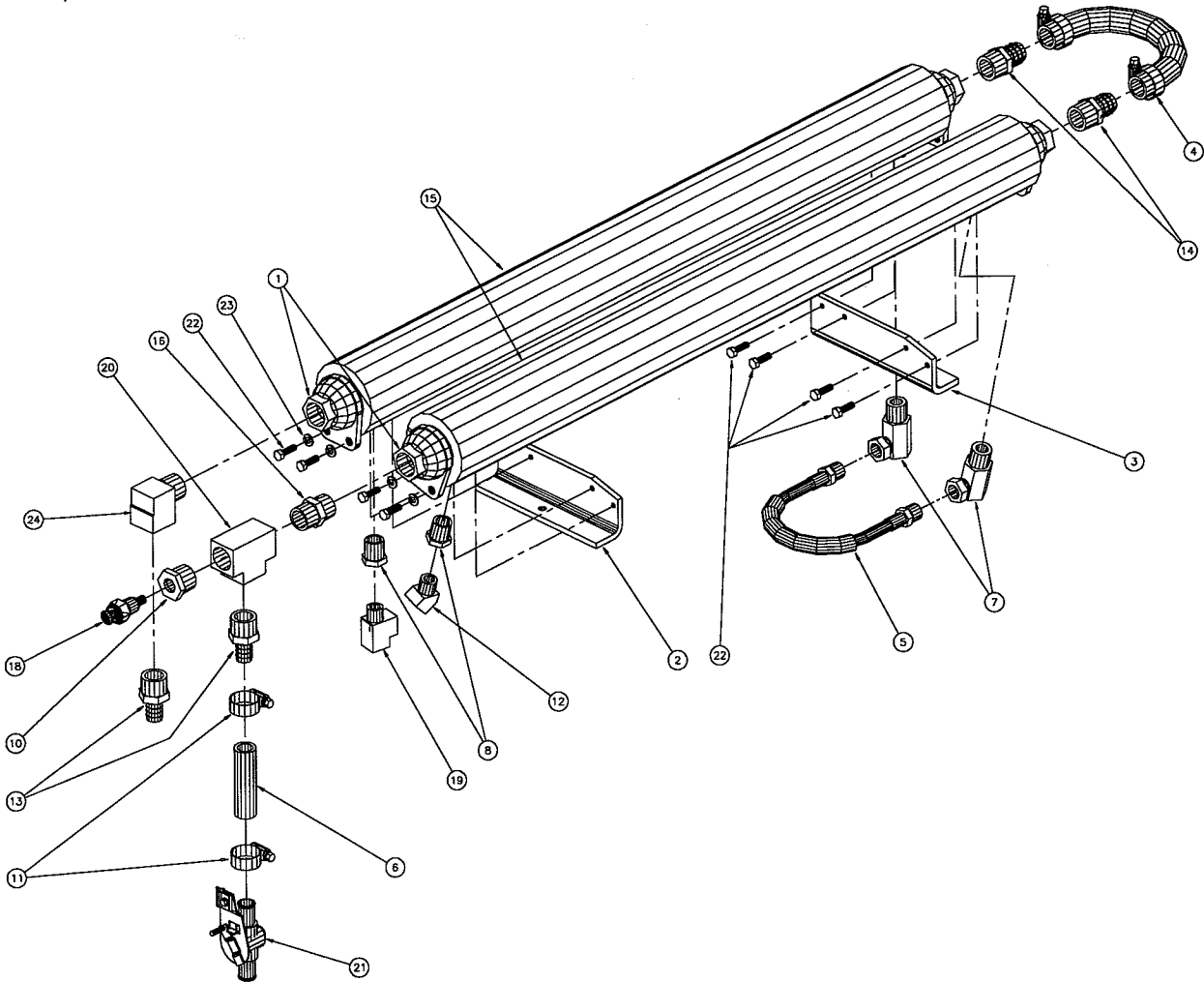

## Dual Heat Exchanger Assembly Parts List

ITEM	PART NO	DESCRIPTION	QTY
1*	038-011	CDS Heat Exchanger Core	2
2	015-055	Bracket, New Style Heat Ex. Mount - Left	1
3	015-056	Bracket, New Style CDS Heat Ex. - Right	1
4	068-173	Hose, Back CDS h/e Loop	1
5	068-071	Hose, 3/8" x 12" Teflon	1
6	068-020	Hose, 5/8" High Temp. Water	3"
7	052-033	8MA-6UFS	2
8	052-064	Bushing, 1/2 M x 3/8 F Brass	2
10	052-259	Bushing, 3/4" MPT x 3/8" FPT Brass	1
11	033-026	Clamp, Size 10 Hose	2
12	052-083	Elbow, 3/8" Brass 45 Street	1
13	052-283	Insert, #1210	2
14	052-338	Insert, #1212 Brass	2
15*	131-008	Insulation, 2 3/8" ID x 1/2 x 72" Long	1
16	052-330	Nipple, 3/4" Brass Hex	1
18	149-021	Sensor, High Temp. Limit 219°F Vanguard Kit	1
19	052-023	Tee, 3/8" Male Street - Brass	1
20	052-336	Tee, 3/4" F x F x F Brass	1
21	169-005	Valve, CDS Hot Water	1
22	143-115	Screw, 1/4-20 x 3/4" HHCS s/s	8
23	174-019	Washer, 1/4 s/s Lock	4
24	052-340	Elbow, 3/4" Brass Street	1

\* For reorder, items 1 and 15 are included together as part no. 038-015.

## Figure 7-10: CDS 4.7 Triple Heat Exchanger Assembly

D3496, Rev A

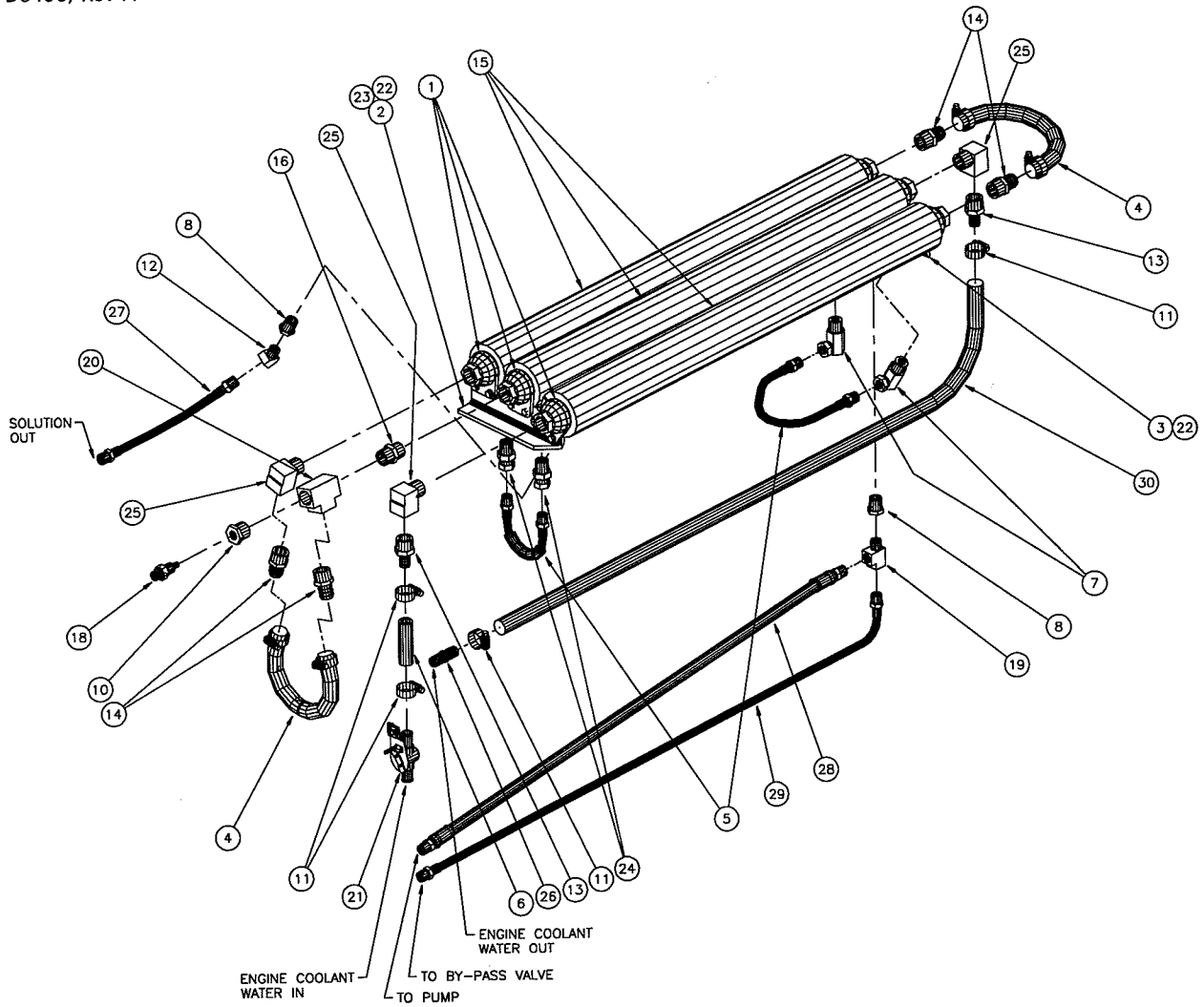

## CDS 4.7 Tripple Heat Ex. Assembly Parts List

ITEM	PART NO	DESCRIPTION	QTY
1*	038-011	CDS Heat Exchanger Core	3
2	015-059	Bracket, Left Side Heat Exchanger Mount	1
3	015-067	Bracket, Right Side Heat Exchanger Mount	1
4	068-173	Hose, Back CDS h/e Loop	2
5	068-071	Hose, 3/8" x 12" Teflon	2
6	068-020	Hose, 5/8" High Temp. Water	3"
7	052-033	8MA-6UFS	2
8	052-064	Bushing, 1/2 M x 3/8 F Brass	2
10	052-259	Bushing, 3/4" MPT x 3/8" FPT Brass	1
11	033-026	Clamp, Size 10 Hose	4
12	052-083	Elbow, 3/8" Brass 45 Street	1
13	052-283	Insert, #1210	2
14	052-338	Insert, #1212 Brass	4
15*	131-008	Insulation, 2 3/8" ID x 1/2 x 72" Long	3
16	052-330	Nipple, 3/4" Brass Hex	1
18	149-021	Sensor, High Temp. Limit 219°F Vanguard Kit	1
19	052-023	Tee, 3/8" Male Street - Brass	1
20	052-336	Tee, 3/4" F x F x F Brass	1
21	169-005	Valve, CDS Hot Water	1
22	143-115	Screw, 1/4-20 x 3/4" HHCS s/s	12
23	174-019	Washer, 1/4 s/s Lock	6
24	052-032	8M-6UFS	2
25	052-340	Elbow, 3/4" Brass Street	3
26	052-119	Mender, 5/8" Brass Hose	1
27	068-094	Hose, 3/8" x 16" Teflon	1
28	068-179	Hose, 3/8" x 41" High PSI	1
29	068-114	Hose, 3/8" x 50" Teflon	1
30	068-020	Hose, 5/8" High Temp Water	45"

\* For reorder, items 1 and 15 are included together as part no. 038-015.

## Figure 7-11: CDS 4.2 Pump and Blower Assembly

D3460, Rev B

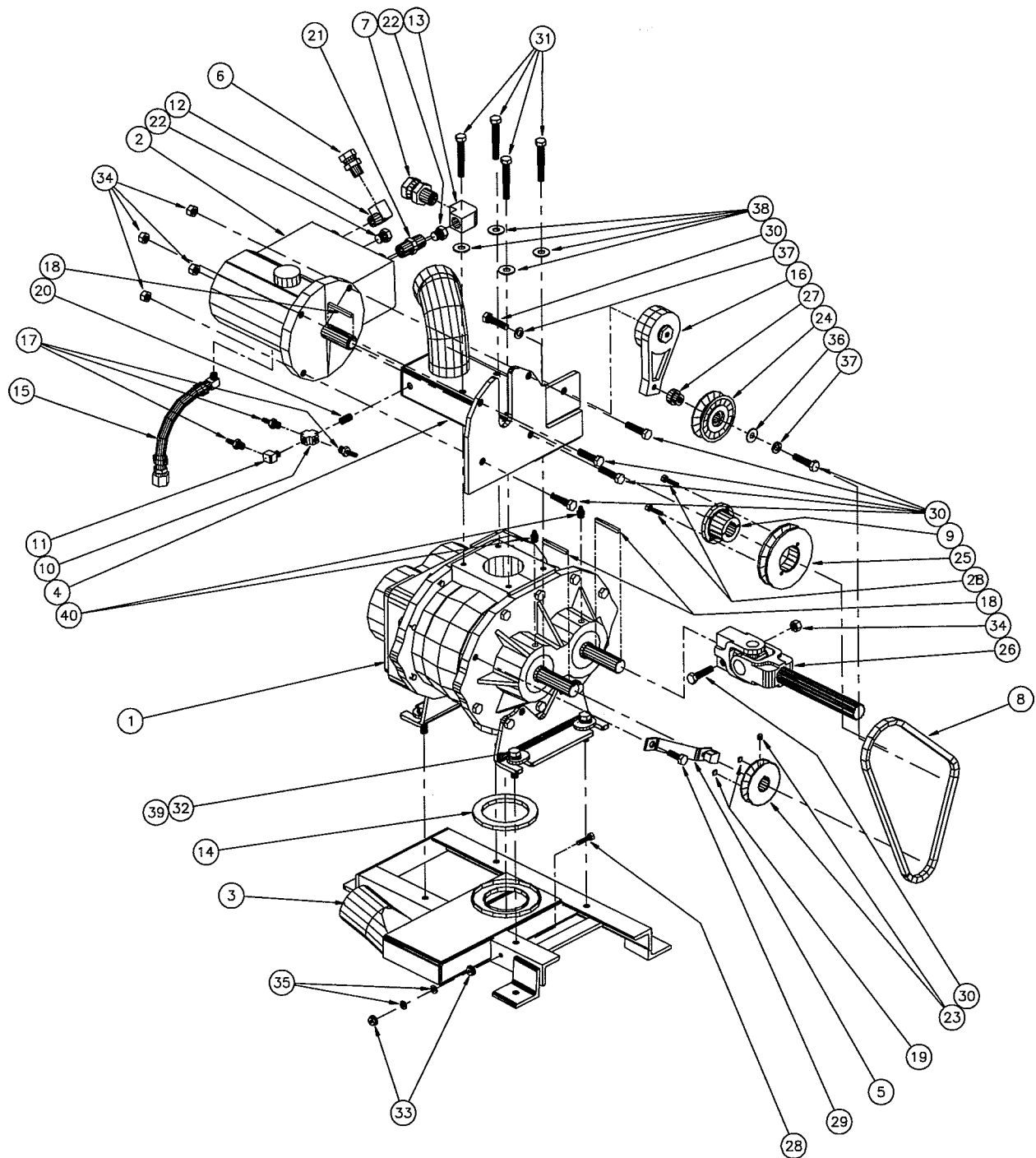



## Figure 7-12: CDS 4.7 Pump and Blower Assembly

D3461, Rev B

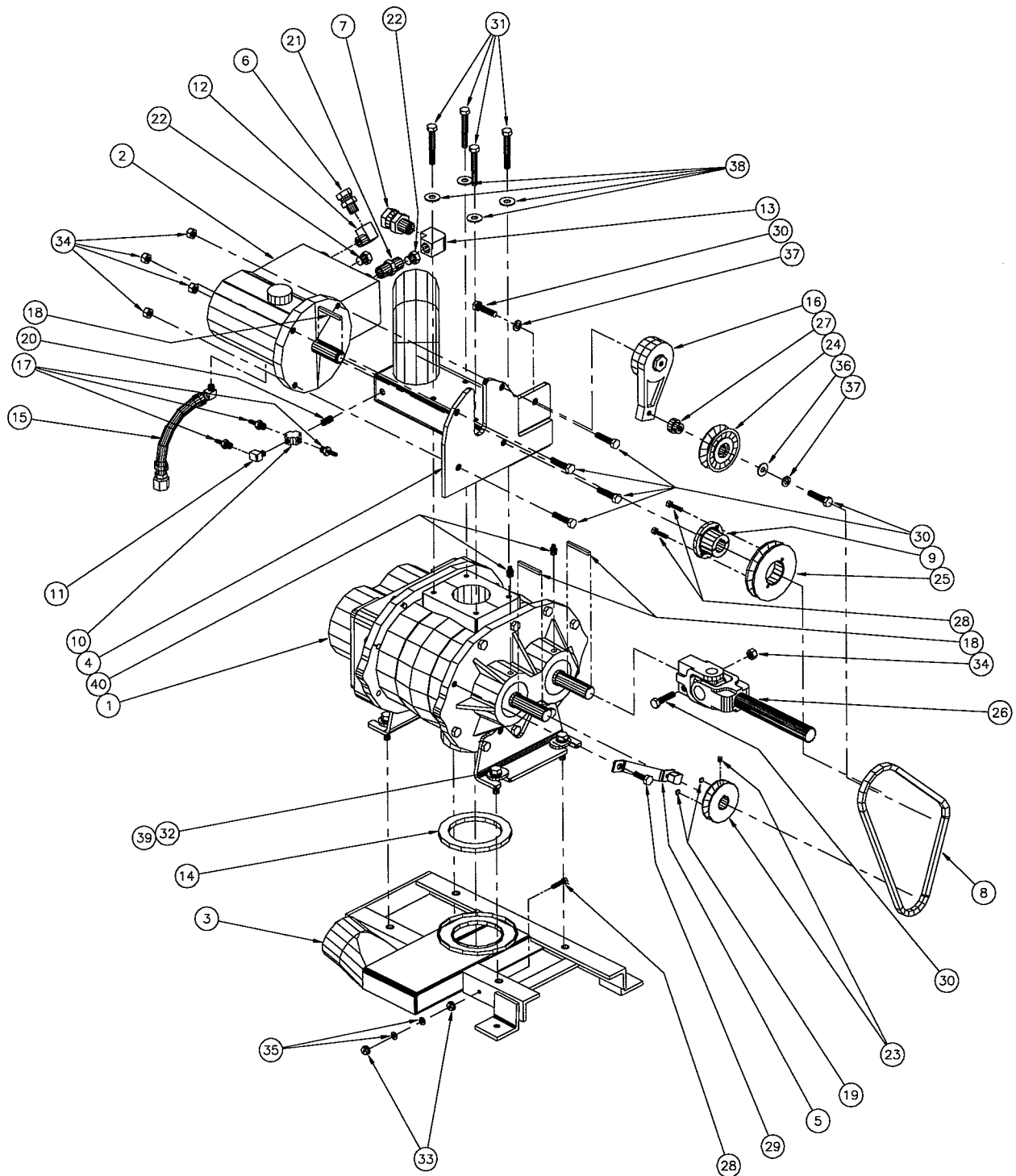

## Pump and Blower Assembly Parts List

ITEM	PART NO	DESCRIPTION	QTY
1	111-022	Blower, 4.2 Hydra Whisper (CDS 4.2)	1
	111-023	Blower, 4.7 Hydra Whisper (CDS 4.7)	1
2	111-050	Pump, 3 GPM High PSI - Hydra	1
3	015-090	Bracket, CDS 4.2 Blower	1
	015-091	Bracket, CDS 4.7 Blower	1
4	015-115	Bracket, CDS 4.2 Pump Mnt for Diaph. Pumps	1
	015-116	Bracket, CDS 4.7 Pump Mnt for Diaph. Pumps	1
5	Figure 7-18	Tachometer Sensor / Bracket Assy	1
6	052-019	6M-6UFS	1
7	052-038	8M-12UFS	1
8	010-022	Belt, Pump and Blower (w/o Cradle Bracket)	1
9	020-019	Bushing, #H x 7/8"	1
10	052-079	Cross, 1/8" Brass	1
11	052-084	Elbow, 1/8" Brass Street	1
12	052-086	Elbow, 3/8" Brass Street	1
13	052-143	Elbow, 1/2" F x F Brass	1
14	057-063	Gasket, CDS 4.2 Blwr Exhaust 1/4" - 300 Deg.	1
	057-056	Gasket, CDS 4.7 Blwr Exhaust - 300 Deg.	1
15	068-163	Hose, Hydra Pump Oil Drain	1
16	109-018	Idler Housing, 3" Pump	1
17	052-293	Insert, #23	3
18	077-001	Key, #3 & 4 Vacuum Pump Drive	3
19	-----	Part of Magnetic Tachometer Sensor (149-010)	2
20	052-057	Nipple, 1/8" Brass Close	1
21	052-076	Nipple, 1/2" Brass Hex	1
22	106-003	Plug, 3/8" Brass	2
23	109-009	Pulley, 2 3/4" x 7/8" - Pump Drive	1
24	109-019	Pulley, 3" Pump Idler	1
25	109-040	Pulley, AK 41 - H Pump	1
26	-----	Splined U-joint Shaft (Part of CDS Drive Shaft)	1
27	154-048	Spacer, Pump Idler	1
28	143-002	Screw, 1/4 - 20 x 1" HHC s/s	3
29	143-018	Screw, 3/8 - 16 x 1" HHC	1
30	143-020	Screw, 3/8 - 16 x 1 1/2" HHC Grade 5 Zinc	7
31	143-097	Screw, 3/8 - 16 x 2 1/2" Grade 5 HHCS	4

---

ITEM	PART NO	DESCRIPTION	QTY
32	143-028	Screw, $\frac{7}{16}$ - 14 x 1 $\frac{1}{2}$ " HHC Grade 5 Zinc	4
33	094-007	Nut, $\frac{1}{4}$ - 20 Whiz	2
34	094-015	Nut, $\frac{3}{8}$ - 16 Two-Way Lock, Zinc Plated Steel	5
35	174-014	Washer, #10 s/s Lock	2
36	174-004	Washer, $\frac{5}{16}$ Flat	1
37	174-021	Washer, $\frac{3}{8}$ Lock	2
38	174-029	Washer, $\frac{3}{8}$ " s/s Rubber Back	4
39	174-022	Washer, $\frac{7}{16}$ Lock	4
40	-----	Grease Fitting, $\frac{1}{8}$ " NPT (Existing)	2

Figure 7-13: Dash Box Assembly

C2712, C3466, Rev B

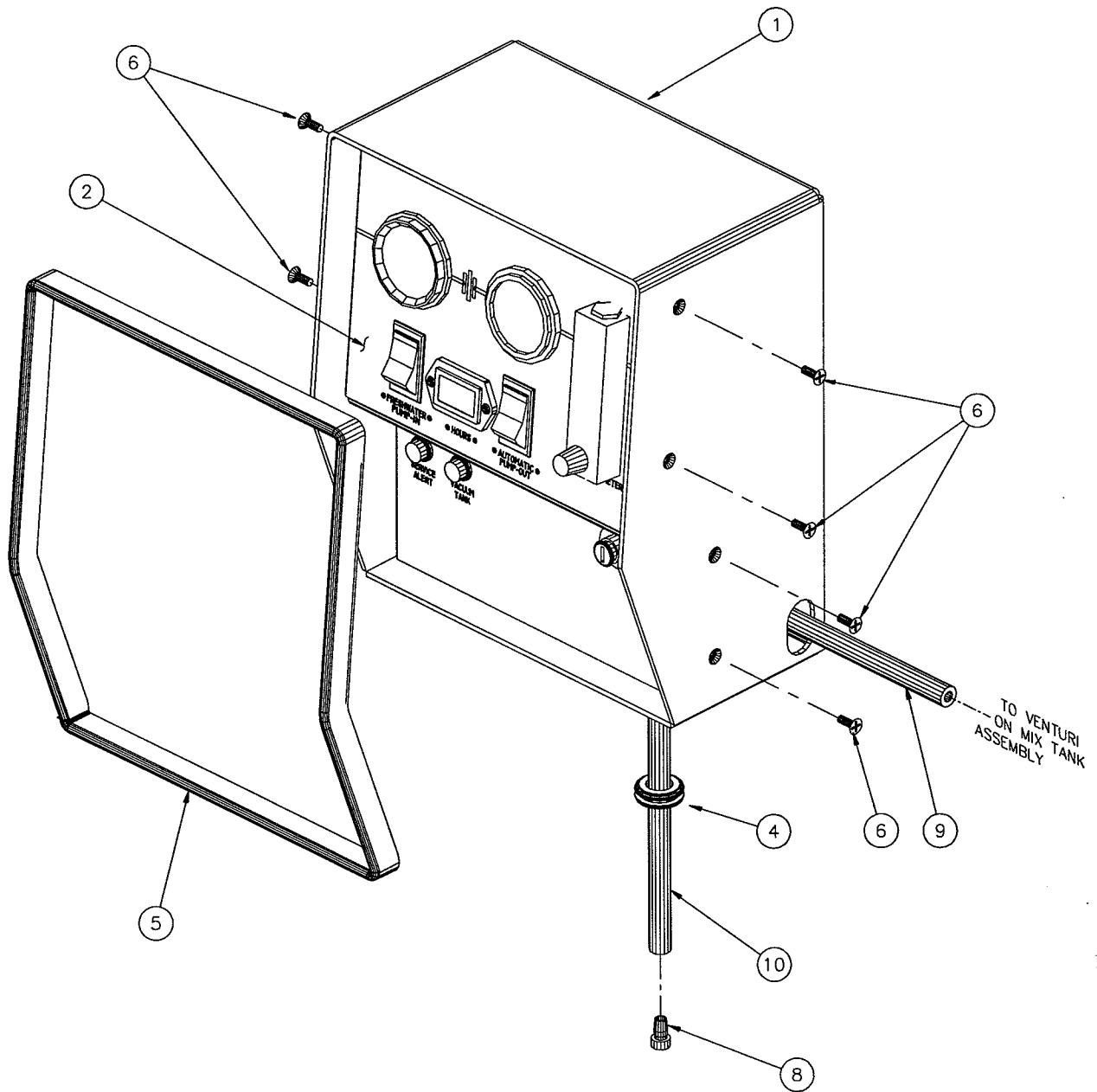

## Dash Box Assembly Parts List

ITEM	PART NO	DESCRIPTION	QTY
1	013-006	Box, CDS Dash	1
2	Figure 7-14	Dash Panel Assembly	1
4	060-002	Grommet, Large Wiring	1
5	131-003	Gasket, CDS Trim	45"
6	143-114	Screw, 10-24 x ½" FHM Phillips s/s	8
7	094-034	Nut, 10-24 s/s Nylock	8
8	169-062	Valve, ¼ Anti-Siphon	1
9	068-025	Hose, ¼" Clear	30"
10	068-025	Hose, ¼" Clear	30"
Not Shown:			
	178-090	Wire Assembly, Vanguard High Temp. Switch	1

Figure 7-14: Dash Panel Assembly

C3465, Rev B

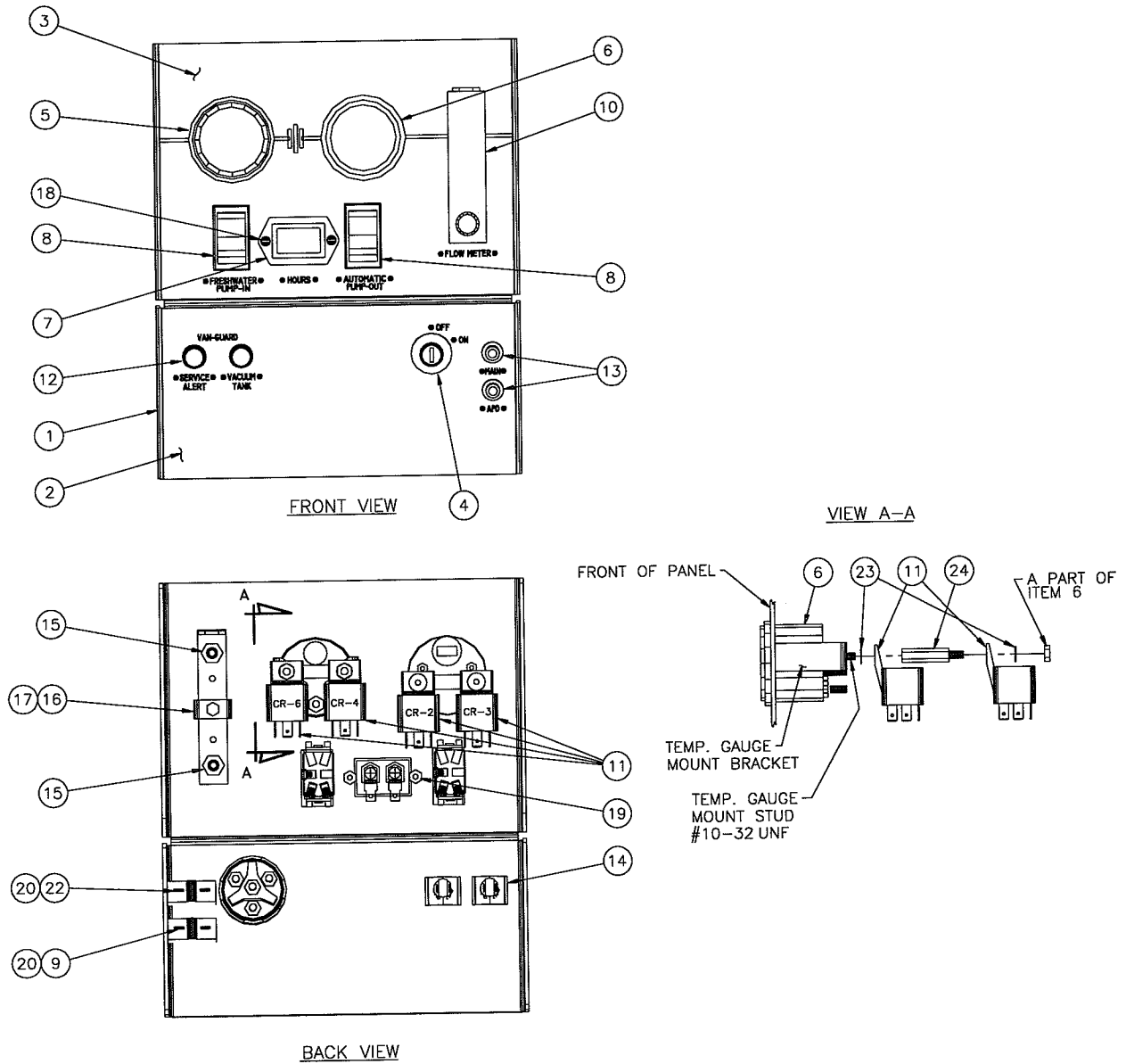

## Dash Panel Assembly Parts List

ITEM	PART NO	DESCRIPTION	QTY
1	100-006	Panel, CDS Dash	1
2	-----	Labels, Lower Dash (Parts of Label Sets Below)	
	081-094	Label, CDS 4.2 - 3 Piece Set	1
	081-020	Label Set, Coit CDS	1
	081-037	Label Set, ServPro CDS 4.2 - 4 Piece Set	1
3	-----	Labels, Upper Dash (Parts of Label Sets Above)	
4	157-008	Switch, Ignition	1
5	074-004	Tachometer, High Pressure Pump	1
6	074-001	Gauge, S/W Water Temperature	1
7	074-011	Meter, Rectangular Hour	1
8	157-007	Switch, 12v DC Lighted Rocker - Black	2
9	018-003	Breaker, 15 amp Circuit	1
10	074-020	Meter, Chemical Flow	1
11	157-022	Switch, Relay	6
12	084-006	Lamp, Red Pilot - Round	2
13	094-024	Nut, 3/8-27 Knurled Finish for Breakers	2
14	033-049	Clamp, Indicator Light	2
15	052-097	Insert, #24	2
16	015-005	Bracket, Chemical Flow Meter Mounting	1
17	143-132	Screw, 10-24 x 1/4 HHC s/s	1
18	-----	Screw, 6-32 x 1/2 Rnd Hd (Part of Item 7)	2
19	-----	Nut, 6-32 Hex (Part of Item 7)	2
20	094-024	Nut, 3/8-27 Knurled Finish for Breakers	2
22	018-005	Breaker, 20 amp Circuit	1
23	174-015	Washer, #10 Outside Star	4
24	154-059	Spacer, 10-32 M/F x 1.25" Long	2
Not Shown:			
	063-007	Harness, CDS Wire - Primary (Dash Box - Males)	1

Figure 7-15 Mix Tank Assembly  
D2967, Rev C

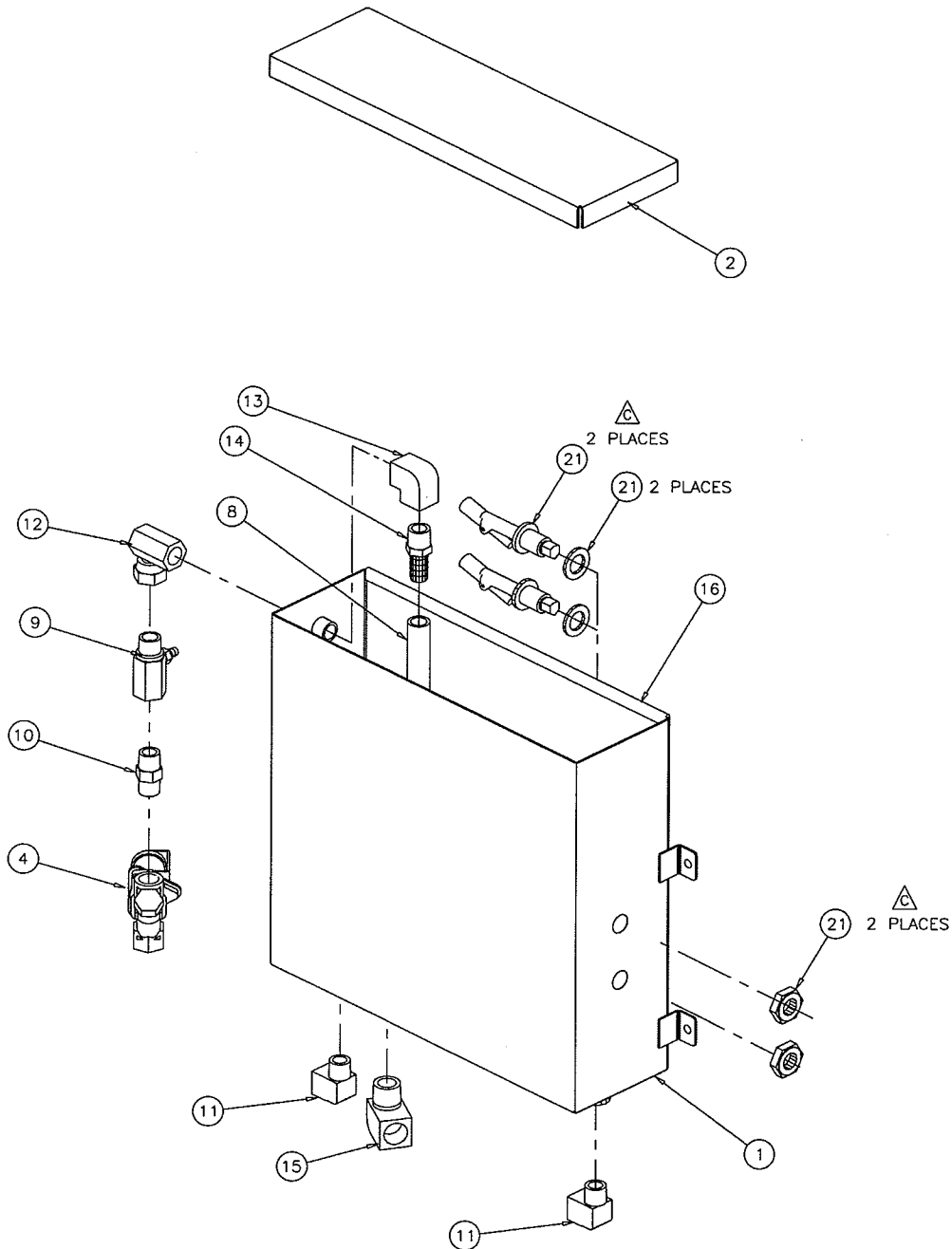



## Mix Tank Assembly Parts List

REF. NO.	PART NO.	DESCRIPTION	QTY
1	159-032	Tank, CDS Chemical Mix	1
2	041-038	Cover, CDS Chemical Mix Tank	1
3	-----	-----	—
4	169-120	Valve, Chemical System Solenoid-12 volt	1
5	-----	-----	—
6	-----	-----	—
7	-----	-----	—
8	068-327	Hose, 1/2" x 10.5" LG Clear Brand	1
9	181-008	Venturi, Low Pressure Injector-Modified	1
10	052-074	Nipple, 3/8" NPT Hex	1
11	052-086	Elbow, 3/8" NPT Street	2
12	052-026	6FA-6UFS	1
13	052-142	Elbow, 3/8" NPT Female	1
14	052-105	Insert, No. 68	1
15	052-087	Elbow, 1/2" NPT Street	1
16	131-027	Trimlok, 12.75" LG CrossFire Brow	1
21	157-031	Switch, Side Mount	2

Figure 7-16: CDS 4.2 Lid Assembly

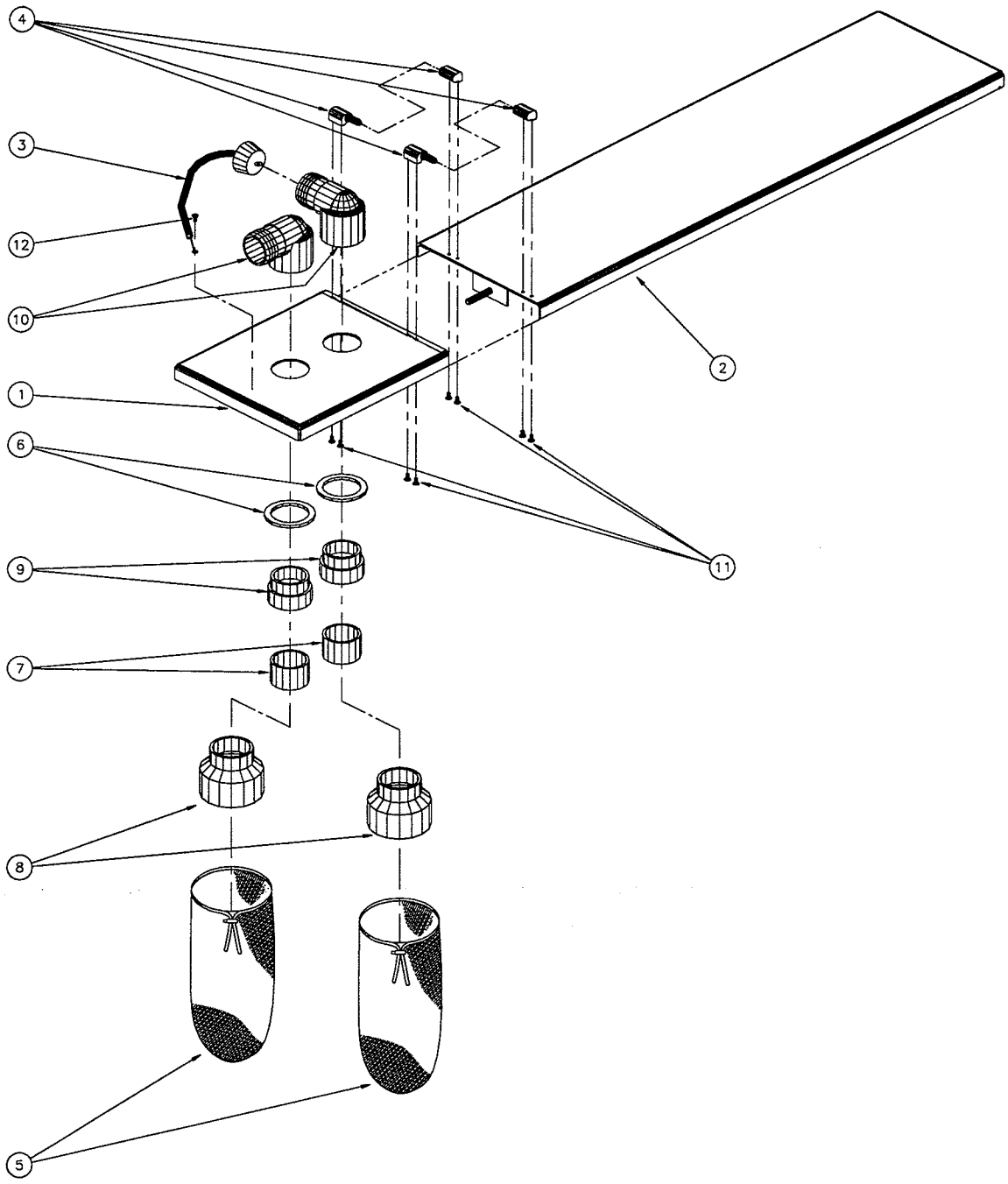
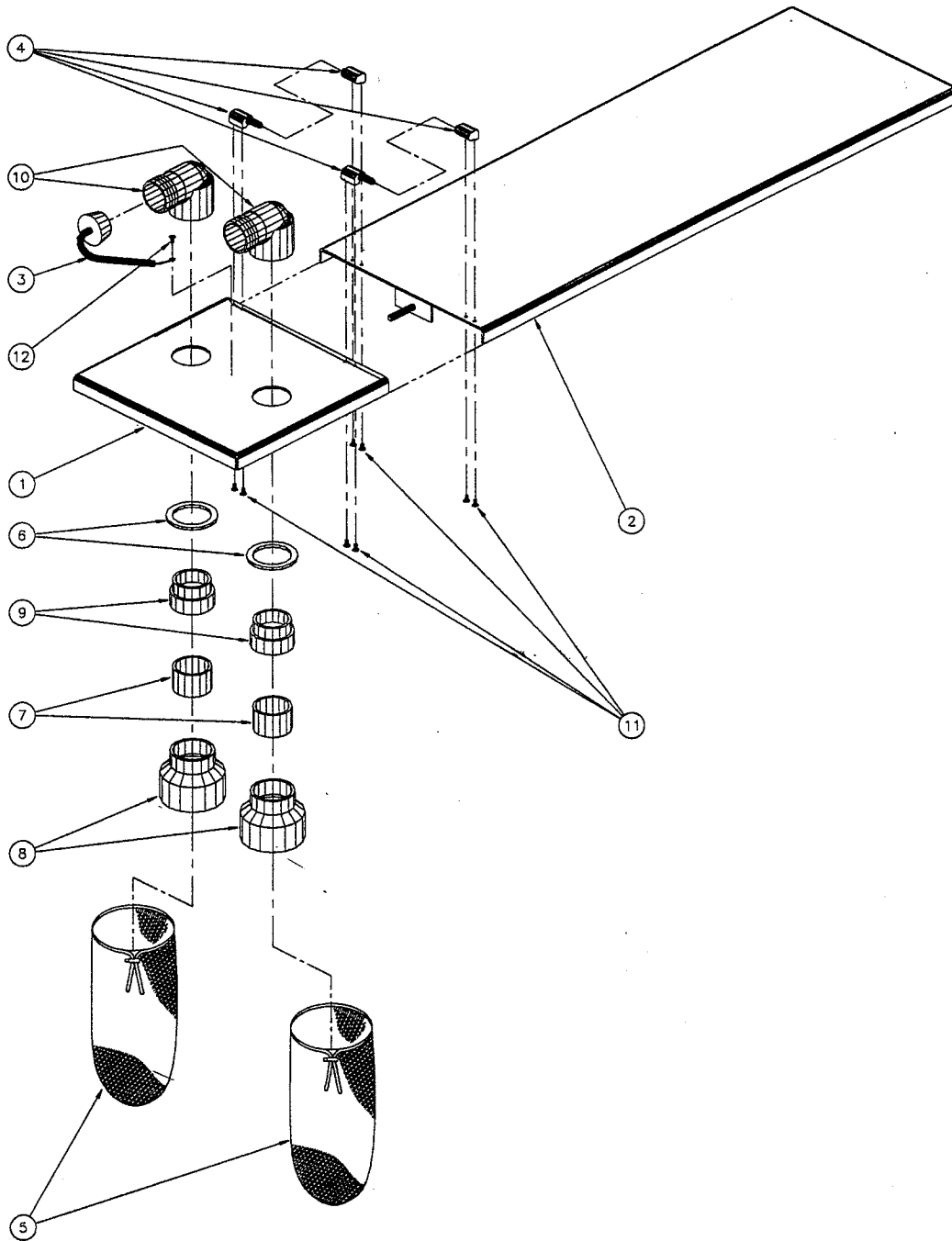

Figure 7-17: CDS 4.7 Lid Assembly



## Lid Assembly Parts List

ITEM	PART NO	DESCRIPTION	QTY
1	041-098	Lid, Front Vacuum Tank (CDS 4.2)	1
	041-094	Lid, Front Vacuum Tank (CDS 4.7)	1
2	041-099	Lid, Rear Vacuum Tank (CDS 4.2)	1
	041-042	Lid, Rear Vacuum Tank (CDS 4.7)	1
3	078-039	Kit, Vacuum Inlet Stopper	1
4	067-017	Hinge Set, Left	2
5	049-030	Filter Bag	2
6	057-015	Gasket, 1 1/2" Bulkhead Fitting	2
7	125-052	Tube, 2" PVC x 1 1/2" Long FB Adapter Sleeve	2
8	052-404	Adapter, 3" F Slip x 2" F Slip	2
9	052-219	Adapter, 2" NPT x 2" F Slip ABS	2
10	052-222	Elbow, 2" Comb - Insert x FPT	2
11	143-060	Screw, 10-24 x 3/8" Flat Hd Machine	8
12	143-166	Screw, 10-24 x 3/8" s/s HHC	1

Figure 7-18: Tachometer Sensor and Bracket Assembly

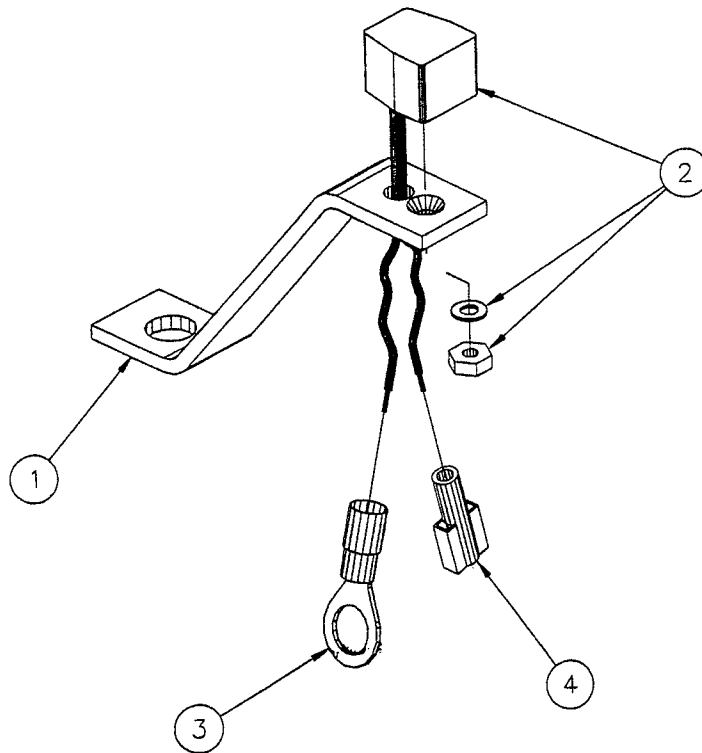

ITEM	PART NO	DESCRIPTION	QTY
1	015-060	Bracket, CDS Tach. Magnet Extension	1
2	149-010	Sensor, CDS Magnetic Tach. (only parts shown are used here)	1
3	037-017	Terminal, 3/8 Stud, 10 GA Wire, Vinyl Insulated	1
4	037-012	Terminal, Fully Insulated Female QC	1

Figure 7-19: Vertical Pump In Tank Assembly

D3715

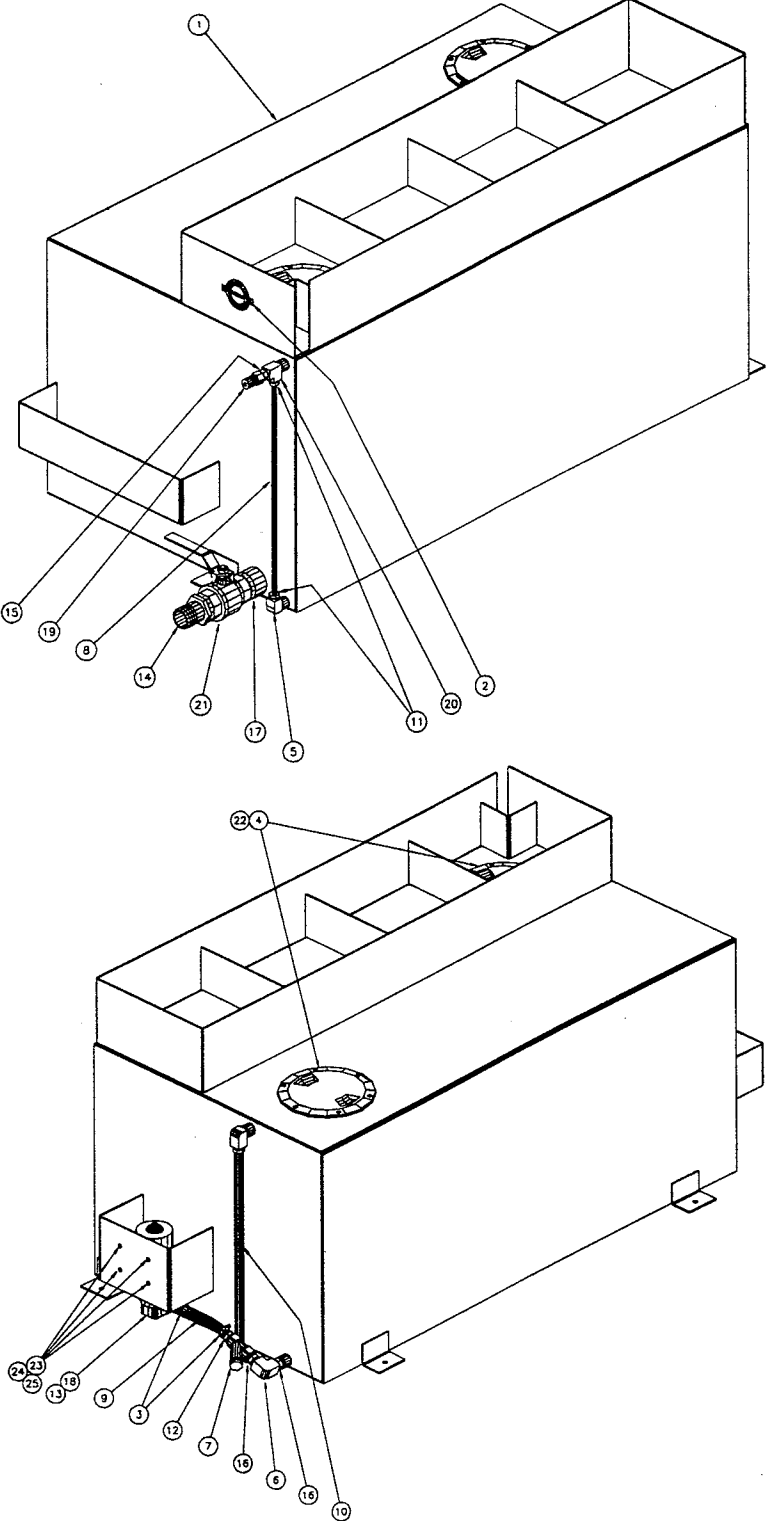

## Vertical Pump In Tank Assembly Parts List

ITEM	PART NO	DESCRIPTION	QTY
1	159-004	Tank, 120 Gallon Vertical	1
2	081-173	Label, "HydraMaster" Accessory	1
3	033-004	Clamp, Size 6 Mini Hose	2
4	041-005	Cover, 6" Pump In Tank	2
5	052-086	Elbow, 3/8" Brass Street	1
6	052-143	Elbow, 1/2" F x F Brass	1
7	049-006	Filter, 1/2" Inline Y - Cat Pump	1
8	068-025	Hose, 1/4" Clear	18"
9	068-327	Hose, 1/2" Clear Braid	6 1/2"
10	068-165	Hose, Pump In Overflow	1
11	052-103	Insert, #64	2
12	052-107	Insert, #88	1
13	052-313	Insert, 1/2" Plastic Swivel Straight	2
14	052-226	Insert, 1 1/2" NPT x 1 1/2" Barb	1
15	052-074	Nipple, 3/8" Brass Hex	1
16	052-076	Nipple, 1/2" Brass Hex	2
17	052-182	Nipple, 1 1/2" Close - Galv. Steel	1
18	111-010	Pump, 35 PSI Elect. Pump In with M Thrds	1
19	052-052	Quick Connect, 660 Male with Viton	1
20	052-023	Tee, 3/8" Male Street - Brass	1
21	169-022	Valve, 1 1/2" Full Port Brass Dump	1
22	143-114	Screw, 10-24 x 1/2" FHM Phillips s/s	12
23	143-113	Screw, 10-24 x 1 1/2" FHM s/s	4
24	094-034	Nut, 10-24 s/s Nylock	4
25	174-001	Washer, #10 s/s Flat	4

**Figure 7-20: Horizontal Pump In Tank Assembly**

D3700, Rev A

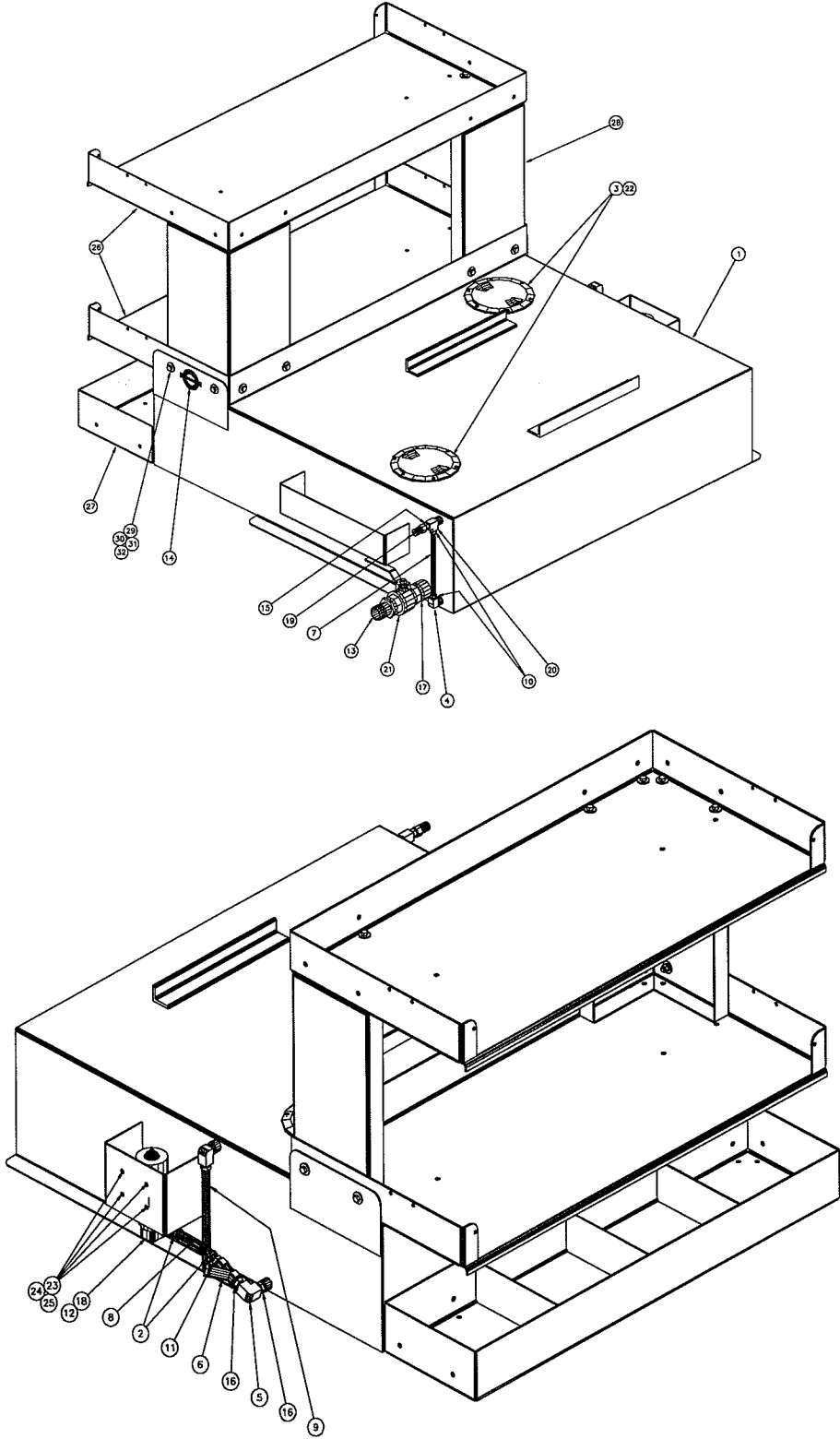



## Horizontal Pump In Tank Assembly Parts List

ITEM	PART NO	DESCRIPTION	QTY
1	159-005	Tank, 120 Gallon Horizontal	1
2	033-004	Clamp, #6 Mini Hose	2
3	041-005	Cover, 6" Pump In Tank	2
4	052-086	Elbow, 3/8" Brass Street	1
5	052-143	Elbow, 1/2" F x F Brass	1
6	049-006	Filter, 1/2" Inline Y - Cat Pump	1
7	068-025	Hose, 1/4" Clear	9 5/8"
8	068-327	Hose, 1/2" Clear Braid	6 1/2"
9	068-165	Hose, Pump In Overflow	1
10	052-103	Insert, #64	2
11	052-107	Insert, #88	1
12	052-313	Insert, 1/2" Plastic Swivel Straight	2
13	052-226	Insert, 1 1/2" NPT x 1 1/2" Barb	1
14	081-173	Label, "HydraMaster" Accessory	1
15	052-074	Nipple, 3/8 Brass Hex	1
16	052-076	Nipple, 1/2" Brass Hex	2
17	052-182	Nipple, 1 1/2" Close - Galv. Steel	1
18	111-010	Pump, 35 PSI Elect. Pump In with M Thrds	1
19	052-052	Quick Connect, 660 Male with Viton	1
20	052-023	Tee, 3/8" Male Street - Brass	1
21	169-022	Valve, 1 1/2" Full Port Brass Dump	1
22	143-114	Screw, 10-24 x 1/2" FHM Phillips s/s	12
23	143-113	Screw, 10-24 x 1 1/2" FHM s/s	4
24	094-034	Nut, 10-24 s/s Nylock	4
25	174-001	Washer, #10 s/s Flat	4
26	166-012	Tray, Air Mover - Removable	2
27	166-014	Tray, 4 Bin Storage - Removable	1
28	083-002	Leg, Tray Support	2
29	143-019	Screw, 3/8 - 16 x 1 1/4" HHC Grade 5 Zinc	16
30	094-014	Nut, 3/8 - 16 Hex	16
31	174-005	Washer, 3/8 Flat	32
32	174-021	Washer, 3/8 Lock	16

## CDS Belts Item No. 20

---

PART NO.	DESCRIPTION
<b>All Vans</b>	
010-016	Belt, 4.2/4.7 Pump Drive
010-022	Belt, '91 Pump Drive
010-023	Belt, '92-93 Pump Drive
<b>Chevrolets</b>	
010-001	Belt, '85 Chev 8 Drive
010-002	Belt, '85-86 Chev 8 Water Pump
010-032	Belt, '86 Chev 8 Drive
010-034	Belt, '87-91 Chev 8 Drive
010-010	Belt, '92 + Chev Drive
010-039	Belt, '97 + Chev 8 with AC
010-046	Belt, '97 + Chev 8 Main Drive
<b>Ford 6</b>	
010-004	Belt, '86 Ford 6
010-028	Belt, '86 Ford 6 Alternator Drive
010-035	Belt, '87-93 Ford 6 Drive
010-040	Belt, '87-93 Ford 6 Drive (with Factory Air)
010-036	Belt, All Ford 6 AC Drive
<b>Ford 8</b>	
010-031	Belt, '86 Ford 8 Drive
010-030	Belt, '87 Ford 8 Drive
<b>Ford 302</b>	
010-029	Belt, '87-89 Ford 302 Drive
<b>Ford 351</b>	
010-008	Belt, '90 Ford 351 Drive
010-029	Belt, '91-93 Ford 351 Drive

---

---

## **Ford Diesel**

010-006	Belt,	'91 Ford Diesel Drive
010-037	Belt,	'92-93 Ford Diesel Drive

---

## **Astro**

010-004	Belt,	'85 Astro Drive
010-026	Belt,	'85 Astro Alternator Drive
010-027	Belt,	'85 Astro Drive
010-032	Belt,	'86 Astro Drive
010-033	Belt,	'87 Astro Drive
010-034	Belt,	'87-91 Astro Drive

---

## **Dodge**

010-038	Belt,	'91-93 Dodge 360 Drive with V-Belt (2 per mach.)
010-047	Belt,	'92+ Dodges Poly-V

Figure 1-21: **Valve Assembly**

C3652

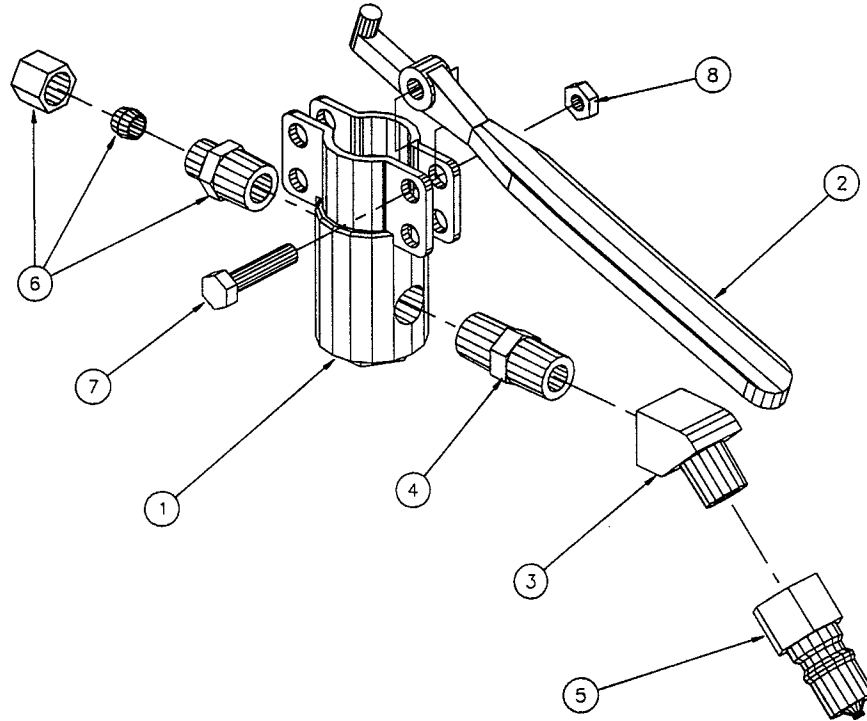

ITEM	PART NO	DESCRIPTION	QTY
1	169-058	Valve, s/s HM Solution	1
2	167-013	Trigger, Hydra Hoe Valve - Brass	1
3	052-082	Elbow, 1/4" Brass 45 Street	1
4	052-095	Nipple, 1/4" s/s Hex	1
5	052-050	Quick Connect, 440 M with Viton	1
6	052-152	Compression, 1/4" Male Hydra Hoe Fitting	1
7	143-002	Screw, 1/4 - 20 x 1" HHC s/s	1
8	094-009	Nut, 1/4 - 20 s/s Nylock	1

Figure 1-22: **Solution Valve Assembly**

B1234, Rev A

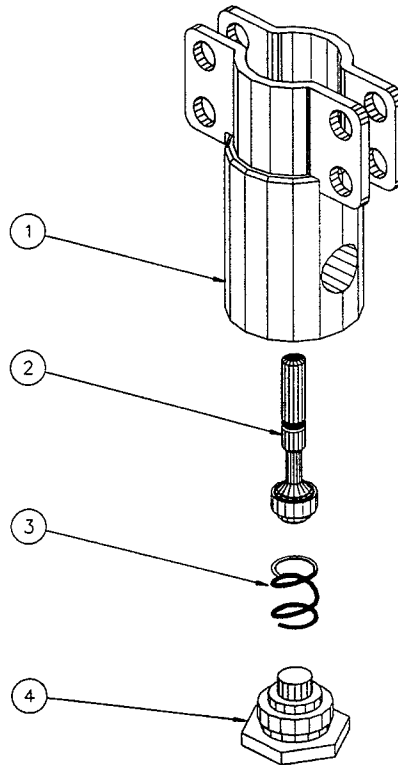

ITEM	PART NO	DESCRIPTION	QTY
1	600-012-001	Valve Body Sub Assembly	1
2	600-012-002	Valve Stem Sub Assembly	1
3	155-003	Spring, HM Solution Valve	1
4	027-001	Cap, Brass	1

Figure 1-23: Valve Stem Assembly

B3743

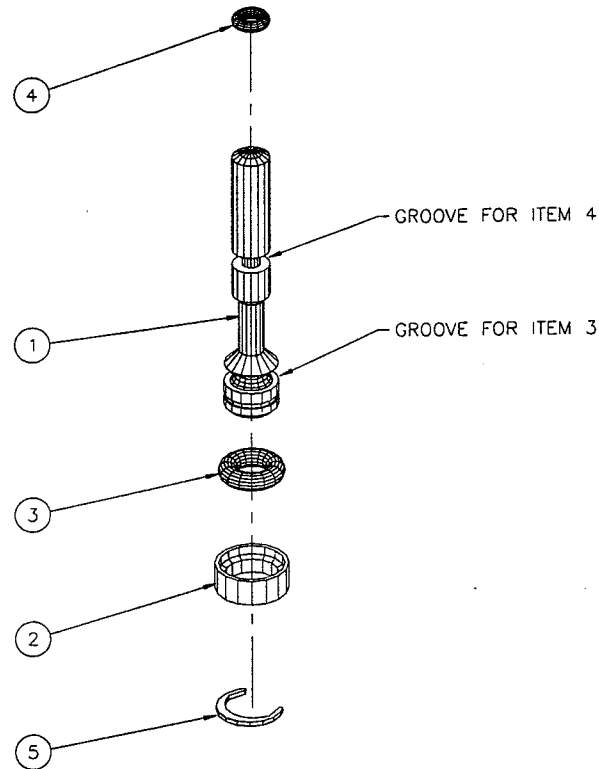

ITEM	PART NO	DESCRIPTION	QTY
1	107-129	Plunger, HM Solution Valve	1
2	139-003	Ring Keeper, HM Solution Valve	1
3	097-010	O-Ring, HM Valve Plunger - Large	1
4	097-022	O-Ring, Solution Valve Flow Meter - Small	1
5	139-004	Ring, Solution Valve Stem Snap	1

Figure 1-24: Hydra Hoe Wand Assembly

C2660

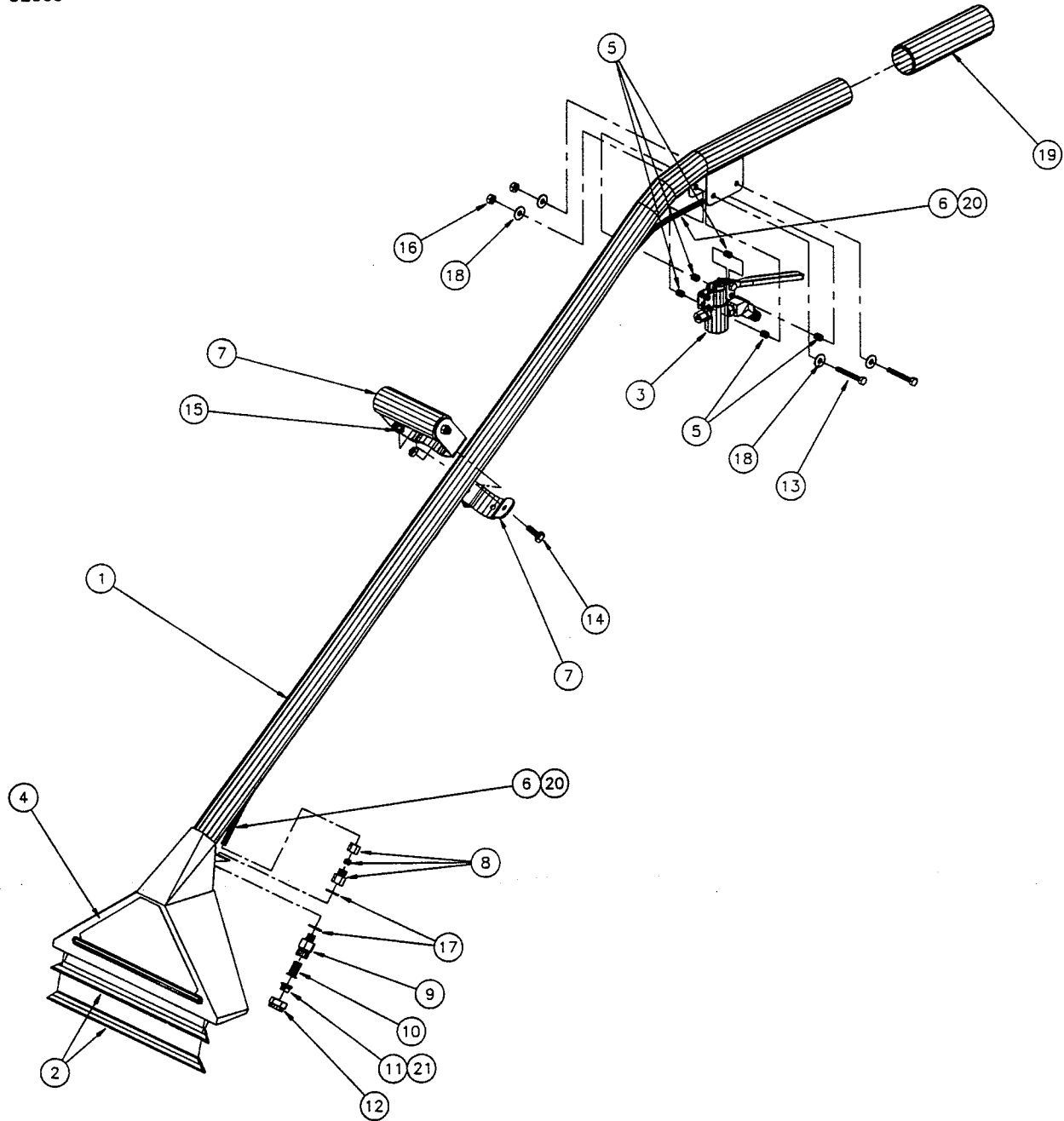

## Hydra Hoe Wand Assembly Parts List

ITEM	PART NO	DESCRIPTION	QTY
1	173-001	Wand Kit, 12" s/s Truckmount	1
2	082-004	Lips, 12" s/s HM Wand (2 Pieces)	1
3	169-055	Valve Assembly, s/s Hydra Hoe with Trigger	1
4	081-015	Label, "HydraMaster" Wand	1
5	154-001	Spacer, 1/4 x 5/16 s/s Solution Valve	5
6	168-001	Tube, Hydra Hoe Solution - 1/4" OD s/s	1
7	061-006	Handle, Pressure Guide	1
8	052-151	Compression, 1/8" Female Hydra Hoe Fitting	1
9	052-153	Housing, Brass Stabilizer Wand Nozzle Fitting	1
10	186-001	Stabilizer - Jet Assembly Group	1
11	076-005	Jet, #6 s/s Hydra Hoe	1
12	094-028	Nut, Brass Jet Assembly Group	1
13	143-005	Screw, 1/4 - 20 x 1 3/4" HHC	2
14	143-012	Screw, 5/16 - 18 x 3/4" HHC s/s	2
15	094-035	Nut, 5/16 - 18 s/s Nylock Half	2
16	094-009	Nut, 1/4 - 20 s/s Nylock	2
17	174-032	Washer, 3/8 s/s Flat	2
18	174-003	Washer, 1/4" s/s Flat	4
19	061-007	Handle Grip Hydra Hoe	1
20	063-003	Harness Wrap, High Temp. 1/4" - Gray	4
21	076-045	Jet, 8004E s/s T	1



Figure 7-25: By-Pass Valve Assembly

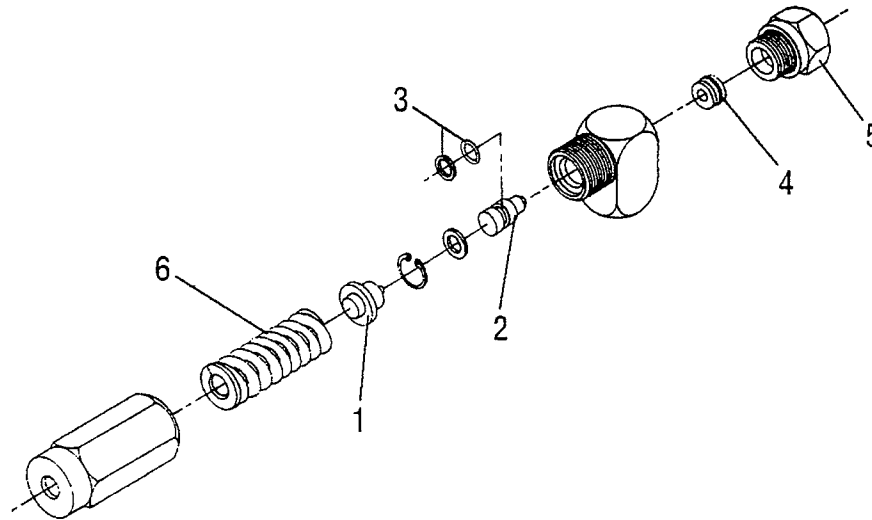

### 169-101 Valve, By-Pass Truckmount

ITEM	PART NO	DESCRIPTION	QTY
1	105-101	Thrust Plate, By-pass Valve	1
2	105-102	Piston Plate, By-pass Valve	1
3	097-028	Seal Set for By-pass Valve	1
4	148-004	Seat and O-Ring, By-pass Valve	1
5	097-005	O-Ring, By-pass Valve Fitting	1
6	155-019	Spring, High PSI By-pass	1
Not Shown:			
	078-102	Kit, By-pass Repair (Complete, Incl. 078-101)	1
	078-101	Kit, Seal and Spring High PSI By-pass (Includes Items 3 and 6)	1

---

# Vacuum System

*CDS 4.2 / 4.7*

## *Section 8-1*

The vacuum blower in this machine is a positive displacement lobe type. The performance and life of this unit is greatly dependent on the care and proper maintenance it receives.

Because of the close tolerances between the lobes and housing of the vacuum blower, solid objects entering the inlet will damage the internal lobes, gears and bearing or drive system.

To prevent this, a stainless steel filter screen has been placed at the vacuum inlet inside the vacuum recovery tank. This stainless steel screen is finger tight and should be removed for cleaning weekly.

◆ CAUTION ◆

When machine is being run for test purposes and the vacuum inlet on top of the machine is open, caution should be used.

Figure 8-1

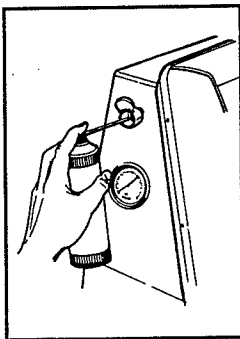

To protect the vacuum blower from overloading and damaging itself, there is a vacuum relief system installed on the vac tank. When the vacuum tank inlet is completely sealed off, a maximum of 12 HG will be attained. At the end of each day, an oil based lubricant should be sprayed in before shutting down the machine. If you fail to lubricate the vacuum blower daily, rust deposits and moisture will decrease the life of the vacuum blower..

◆ CAUTION ◆

Foam passing through the blower could lead to serious problems. Therefore,

it is important to keep the vacuum tank foam free.

Read the vacuum blower manual carefully for proper oil change and grease application. The maintenance log may differ slightly from the manual, but the truck-mounted carpet cleaning machine application is very demanding of the vacuum blower and therefore it should be maintained more regularly.

◆ CAUTION ◆

NOTE: The Vacuum tank is protected from overflowing by a vacuum tank float kill switch. The switch is not activated by foam, only by liquid.

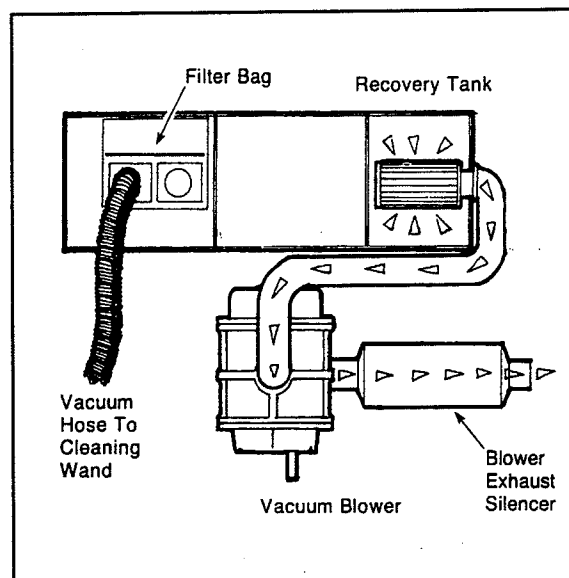

Figure 8-2: Vacuum System Flow

## VACUUM TANK FILTER BAGS

HydraMaster filter bags are designed to trap lint, sand and dirt that would normally collect at the bottom of your vacuum tank. The use of these bags, if emptied at the end of each job, will eliminate the build-up of much of the debris in the tank. The drawstring top of these bags is designed to be slipped around the incoming dirty water inlet in the vacuum tank.

## **BLOWER LUBRICATION**

At the gear end the timing gear teeth are lubricated by being partially submerged. The gear teeth serve as oil slingers for gear end bearings. At the drive end the bearings are grease lubricated.

## **FILLING PROCEDURE**

Remove square head vented oil fill plug on gear end. Remove oil level plug located in the head plate. Fill gear case until oil drips out of the oil level hole.

Use lubricants as listed below.

Add fresh oil as required to maintain proper level. The oil should be drained, flushed and replaced every 300 hours. The oil drain plug is under the head plate.

**NOTE:** Older units may have oil fill level and drain holes located in the cast iron gear case instead of in the head plate.

Bearings on drive end of blower require grease lubrication every 300 hours of operation. Bearings which require grease lubrication will have a grease fitting at each bearing. When regreasing, the old grease will be forced out of the vents during operation. To prevent damage to seals, these vents must be kept open at all times.

## INSTRUCTIONS FOR OIL LUBRICATED GEARS AND BEARINGS

Blower Discharge Temperature	Oil Grade USA	Oil Viscosity, Centistokes at 40°
-40° to 32° F (-40° to 0° C)	SAE 10W	45
32° to 100° F (0° to 38° C)	SAE 20	100
100° to 275° F (38° to 135° C)	SAE 40	200
over 275° F (135° C)	SAE 50	250

In applications with extreme variations in ambient temperature a 20W - 50W multiple viscosity oil is recommended.

## GREASE LUBRICATED BEARINGS

Blower Discharge Temperature	Grease Type
-40° to 275° F (-40° to 120° C)	No. 2 Bearing Grease

# Blower Troubleshooting

CDS 4.2 / 4.7

Section 8-5

No	Problem / Possible Cause	Solution
1	There is no vacuum or a loss of vacuum.	
1.1	The <i>stainless steel filter</i> is clogged.	Clean or replace the filter.
1.2	The <i>filter bag</i> is clogged.	Clean or replace the filter bag.
1.3	The <i>vacuum tank dump valve</i> is "open" or defective.	If water drips from the valve when the machine is not running, the valve will cause a vacuum loss when the machine is running. Replace it if it is defective.
1.4	The <i>hose</i> on the live hose reels is collecting water.	Unroll the entire length of the hose each time you use it.
1.5	The <i>vacuum hose</i> is plugged.	Remove the obstruction by reversing the vacuum hose.
1.6	There is a restriction in the <i>cleaning tool</i> .	Remove the obstruction.
1.7	The <i>vacuum tank seal</i> is defective.	Replace the seal.
1.8	The <i>hose</i> from the blower to the recovery tank is kinked or has collapsed inside.	Replace or reshape the hose. <b>NOTE:</b> A special reinforced hose is required for replacement.
1.9	There is a hole in the <i>recovery tank</i> .	Inspect the tank for leaks using smoke and weld the tank if it is required.
1.10	There is a hole in the <i>vacuum hose</i> .	Repair or replace the hose.
1.11	The <i>vacuum release</i> is loose.	Readjust the vacuum release.
1.12	The <i>engine speed</i> is too low.	Adjust the speed.

No	Problem / Possible Cause	Solution
1.13	The <i>vacuum blower's</i> end plates or lobes are worn.	Replace the worn components. <b>NOTE:</b> This must be accomplished by a qualified technician.
1.14	There are <i>vacuum leaks</i> around the top collector box.	A vacuum leak can usually be detected by spraying a mist of WD40 or blowing smoke towards the leak. The mist or smoke will be sucked into the leak. When you see the leak, repair it.

No	Problem / Possible Cause	Solution
<b>2</b>	<b>The blower is noisy.</b>	
2.1	There is an <i>exhaust</i> leak between the blower and the silencer.	Inspect the fittings to determine where the air leak is. Repair as necessary.
2.2	The <i>blower</i> is out of oil or the gears may be bad. <b>NOTE:</b> Permanent damage may result from a lack of lubrication.	Add oil. If the noise continues, replace the gears or blower. <b>NOTE:</b> Replacement of the gears must be accomplished by a qualified technician.
2.3	The <i>silencer</i> is bad.	Inspect it for an external hole. Repair or replace the silencer.
2.4	The <i>lobes</i> are hitting.	Replace the blower.
2.5	The <i>engine</i> is running at the wrong speed. This is noticeable because the blower noise increases with speed.	Adjust the engine to run at the proper speed.
2.6	The <i>bearings</i> are worn.	Remove and replace the bearings as required. <b>NOTE:</b> This process must be accomplished by a qualified technician.



No	Problem / Possible Cause	Solution
<b>3</b>	<b>The blower will not turn.</b>	
3.1	The <i>lobes</i> are locked up because of rust, burnt chemical foam, or a sugar-like substance has been vacuumed up from the carpet.	<p>a. Most <i>burnt foam</i> and <i>rust</i> can be removed by soaking the lobes with liquid wrench. After soaking the lobes, with the machine running, pour a half gallon of hot water into the top of the blower. Then spray WD40 or Pennz Lube into the top of the blower to displace the water.</p> <p>b. Any <i>sugar-like substances</i> can be removed by soaking the lobes with hot water.</p>
3.2	There is debris in the <i>blower</i> .	Remove the debris. A stainless steel filter is provided at the vacuum inlet in the vacuum tank to prevent this problem.
3.3	The blower has broken <i>gears</i> or shattered <i>lobes</i> .	Rebuild or replace the blower. <b>NOTE:</b> Rebuilding the blower must be accomplished by a qualified technician.

No	Problem / Possible Cause	Solution
4	The shaft turns, but the lobes do not.	
4.1	The <i>shaft</i> is broken inside the blower.	Replace the blower.

---

# *Electrical System*

*CDS 4.2 / 4.7*

*Section 9-1*

The electrical system has been specifically designed with the technician in mind. Often the most difficult problem to trace is an electrical failure.

The entire electrical system operates on 12 volts DC which is provided by your truck's battery.

## **VANGUARD SYSTEM**

This unit is equipped with a Vanguard System. The Vanguard System monitors two sensors: a coolant temperature switch and an oil pressure switch.

The *temperature switch* is a normally open switch. The contacts in the switch, if you were to check them 'off the shelf,' would be open. When the switch reaches its preset limit it will close the contacts and allow the wire connected to it (green and white) to be grounded. In other words a failure (high temperature situation) would be sensed by the system, resulting in the clutch drive being deactivated.

The oil *pressure switch* is a normally closed switch. The contacts in the switch, if you were to check them 'off the shelf,' would be closed. Until the switch reaches its preset limit the contacts are closed and thus grounded. When the switch senses sufficient oil pressure has built up, then the contacts in the switch open and the switch is no longer grounded. So when a failure is sensed (a loss of oil pressure) the contacts in the switch again close and the switch will provide a ground through the blue wire. This results in the clutch drive being deactivated.

◆ CAUTION ◆

It is very important to tie up any loose wires or hoses near the drive shaft area.

Tie wraps are sufficient for wires and small hoses. When securing large hoses or wiring harnesses in the area of the drive shaft, a hose clamp with a clear vinyl hose inserted onto the clamp should be used to tie down these components. For example, on Dodge installations, if the fuel injector wires are not properly secured the wires could rub against the CDS drive shaft causing a short in the electrical system of the van.

Figure 9-1 Wiring Schematic  
D2800, Rev H

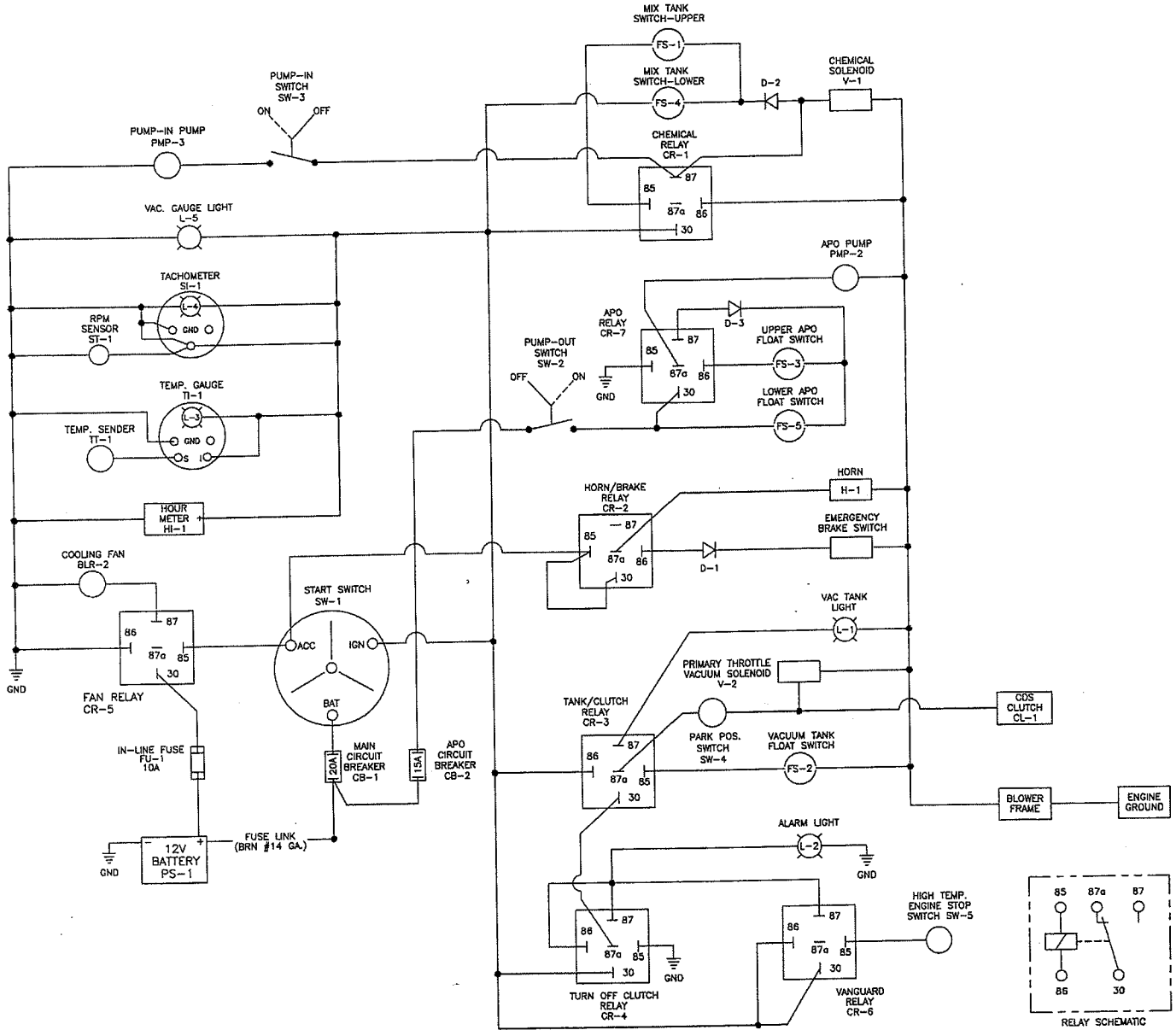

Figure 9-2 Wiring Diagram

D2953 Sht 1, Rev H

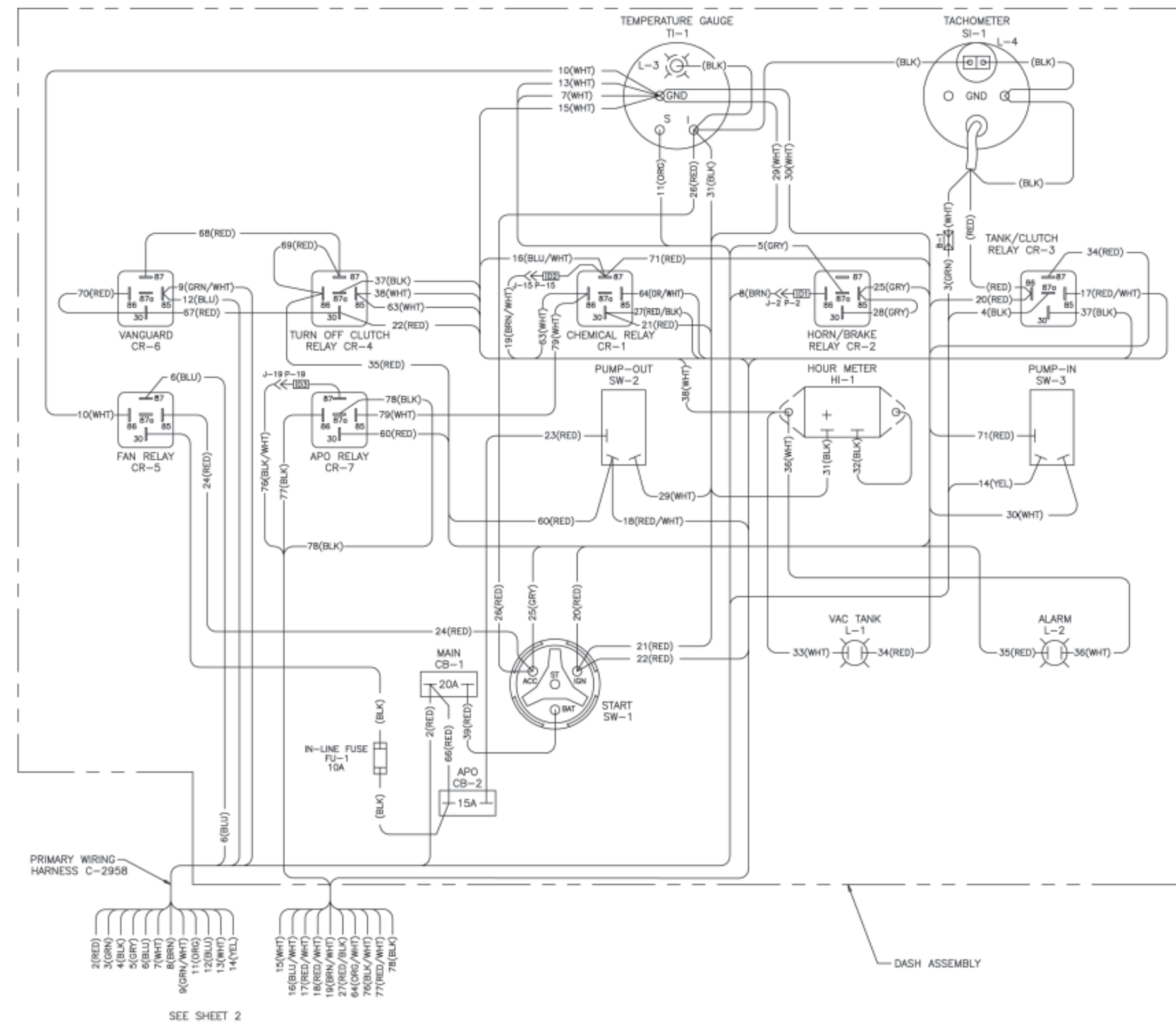
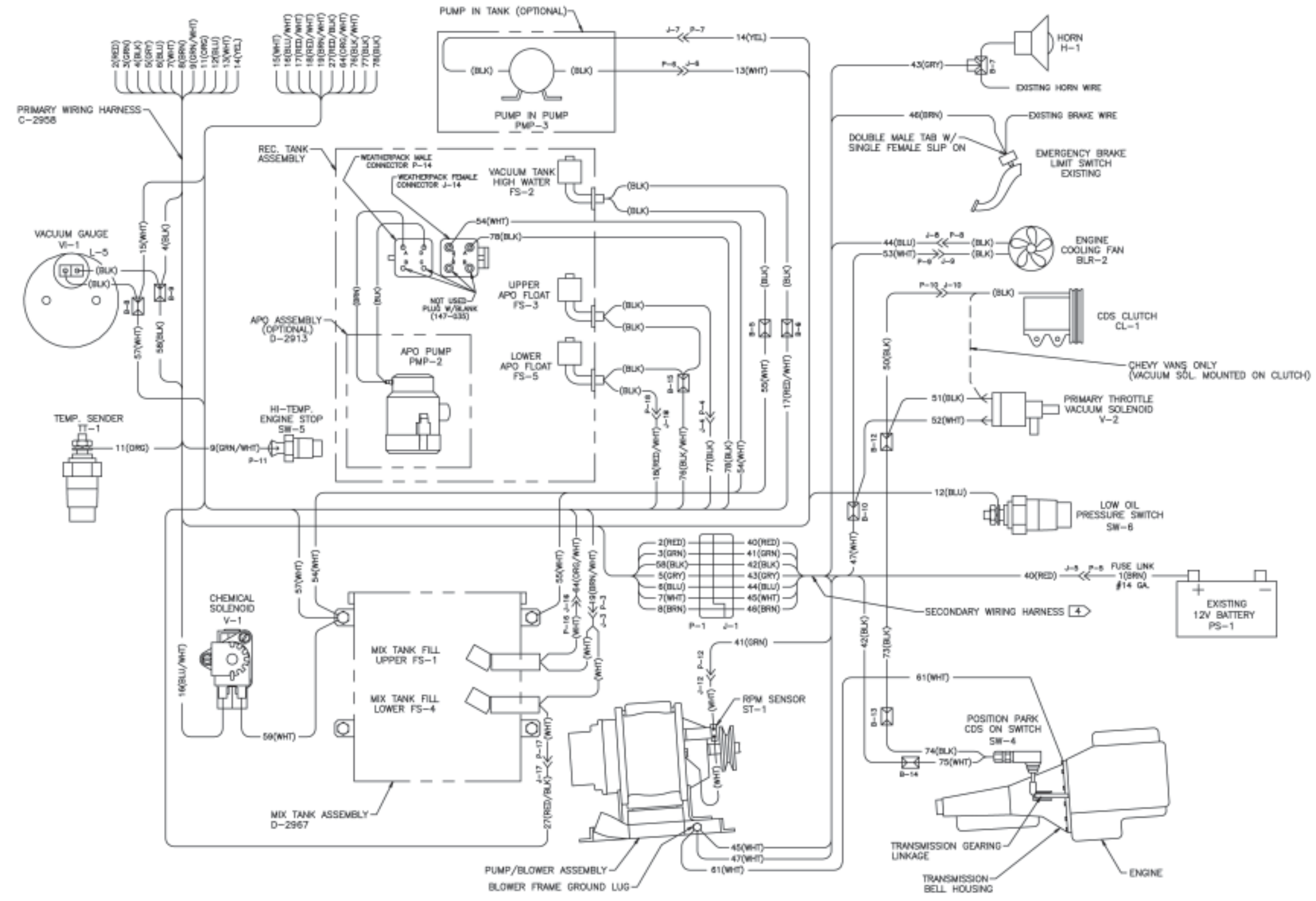

Figure 9-3 Wiring Diagram  
D2953 Sht 2, Rev H



---

# *Electrical Troubleshooting*

*CDS 4.2 / 4.7*

*Section 9-6*

<b>No</b>	<b>Problem / Possible Cause</b>	<b>Solution</b>
<b>1</b>	<b>The battery voltage is low.</b>	
1.6	Defective battery.	Remove and replace.
1.7	Corroded battery terminals.	Clean terminals and battery posts.
1.8	Low battery fluid.	Add water to appropriate level.
1.9	Loose wiring within electrical system.	Examine all terminal connections and verify that they are secure.
1.10	Electrical short in wiring system.	Examine electrical systems for bare wires.
1.11	Poor ground connection.	Examine terminal and remove corrosion is necessary.



No	Problem / Possible Cause	Solution
2	The hour meter is inoperative.	
2.1	Time is not advancing correctly.	<ul style="list-style-type: none"><li>a. Verify 12 volts DC is available at the hour meter with the ignition switch turned on. This can be accomplished with a volt meter or a test lamp.</li><li>b. Remove and replace hour meter if 12 volts is available.</li><li>c. A nylon gear within the clock may have been jammed due to a sudden jolt of the machine or truck. you may try simply tapping on the meter to try to free the nylon gear.</li></ul>

---

# *Machine Maintenance*

*CDS 4.2 / 4.7*

## *Section 10-1*

To avoid costly repairs and down-time, it is imperative to develop and practice good maintenance procedures from the beginning. These procedures fall into daily, weekly, monthly and quarterly increments, and are outlined below. All recommended maintenance must be performed by competent service personnel.

**Important:** Record date and machine hours in maintenance log.

We have provided a maintenance log for your convenience at the end of this section. *Records of maintenance must be kept and copies may be required to be furnished to HydraMaster before the warranty is honored.* It is recommended that you affix a copy of the log on the vehicle door near your unit for convenience and to serve as a maintenance reminder.

## **OPERATIONAL MAINTENANCE**

### **DAILY**

Check engine oil level.

Inspect garden hose screen. Clean as needed.

Visually inspect machine for loose wires, oil leaks, water leaks, etc.

Inspect vacuum tank s/s filter and filter bag for tears, holes, etc.

Clean, repair or replace as needed.

Lubricate blower with an oil based lubricant through blower inlet.

### **WEEKLY**

Check oil level in blower.

Check high pressure pump oil. Add as necessary.

Check drive shaft system set screws. Tighten as needed.

Check pump drive belt for wear.

Check pump pulleys.

Check high pressure water lines for wear or chafing.

Check engine compartment fuel line for any chafing, especially near rotating parts.

Check engine compartment wiring for any chafing, especially near rotating parts.

Check CDS unit wiring for any chafing.

Check all nuts and bolts. Tighten as needed.

Inspect vacuum relief valve. Clean and lubricate as necessary.

Clean vacuum tank thoroughly with high pressure washer.

Flush water and chemical system with 50/50 white vinegar solution.

Check gauge RPMs. Adjust to 2600 RPMs at blower.

## MONTHLY

Change engine oil.

Check engine air cleaner filter. Clean as necessary.

Remove pressure By-pass Valve piston plate. Grease plate. Reinstall.

Check water level in battery. Clean connections as needed.

Grease drive shaft u-joints.

(See Drive Shaft Maint. at the end of this chapter.)

## QUARTERLY

Change oil in blower.

Change oil in pump.

Grease blower bearing fittings.

## YEARLY

Give truck complete tune-up.

Flush the truck's cooling system. Add new anti-freeze.

Change the truck's transmission fluid.

## AS REQUIRED: DE-SCALING

Scale deposits on the interior of the heating system can cause a noticeable loss in heating performance. Deposits of this kind result from hard water deposits, excessive chemical use, improper chemicals, etc. The frequency with which de-scaling procedures are required will vary.

If your area has particularly hard water or you see evidence of deposits in the water system, you may have to de-scale monthly. To de-scale your system, add an appropriate de-scaler chemical to your mix tank. Circulate it through the heating system. Let it stand. Flush and repeat as necessary. Clean all screens and strainers, and check them frequently following de-scaling.

## OVERALL MACHINE MAINTENANCE

**Maintaining the original appearance of your unit is important for two reasons:**

1. It represents a big dollar investment for your cleaning business and its appearance should reflect that fact. A dirty machine is not professional.
2. Maintenance, troubleshooting, and repair is much easier to accomplish on a clean, well maintained unit. Regular cleaning of the machine offers you an opportunity to visually inspect all facets of the machine and spot potential problems before they occur.

**The following maintenance is recommended by the manufacturer at the frequency indicated:**

### AFTER EACH JOB

Check recovery tank, stainless steel filter and filter bag as required.

### DAILY

Wipe machine down thoroughly with a damp cloth.  
Flush recovery tank out thoroughly.

Empty filter bag and inspect for rips, tears, etc. Replace as needed.  
Remove, thoroughly clean and reinstall stainless steel filter screen in recovery tank.

Inspect and clean vacuum slot on cleaning wand.

Check wand head for sharp edges that could tear carpet. File down as needed.

Clean wand to maintain original appearance.

Wipe down vacuum and high pressure hoses as needed.

Visually inspect hoses for cuts, etc.

## WEEKLY

Wipe down entire unit as needed.

Apply good coat of auto wax to all painted surfaces inside and out, and to control panel.

Thoroughly clean recovery tank using high pressure hot water (unit with optional high pressure cleaning gun may be used for this).

Remove stainless steel filter in recovery tank and thoroughly clean, removing all lint build-up. Inspect for damage and reinstall.

Remove filter bag. Thoroughly clean and reinstall. If torn, replace.

Empty chemical from chemical container. Wash out thoroughly to remove any chemical build-up.

Inspect chemical feed line strainer and use 50% white vinegar/water solution to remove any chemical build-up.

Thoroughly clean wand and inspect for clogged jet, debris in vacuum slot and leaking fittings at valve.

Apply light coat of auto wax to wand.

Thoroughly clean vacuum and high pressure hoses including hose cuffs. Inspect for wear or damage to hoses and quick connect fittings.

Inspect garden hose connect/adaptor screen for debris. Remove and clean thoroughly.

Inspect all lines for wear or abrasions that may cause possible leaks.

# Drive Shaft Maintenance

Figure 10-1: Drive Shaft Assembly  
B3619

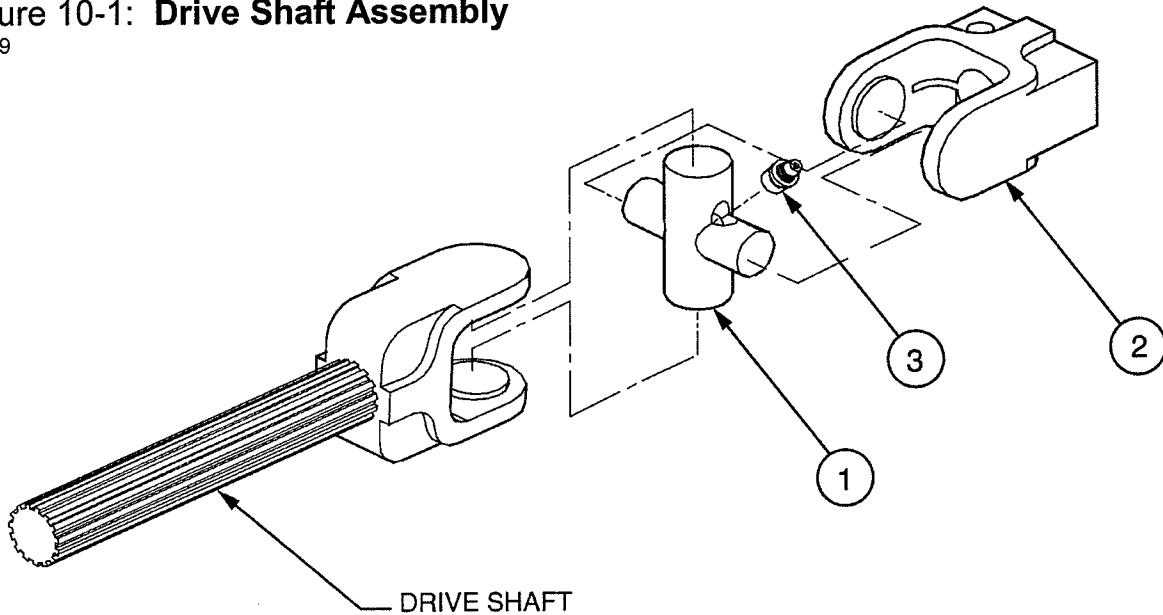

ITEM	PART NO	DESCRIPTION	QTY
1	039-011	Replacement U-Joint for CDS Drive Shaft	1
2	039-012	Replacement Yoke for CDS Drive Shaft	1
3	-----	Zerk Grease Fitting, 1/8" NPT	1

## LUBRICATE ZERK FITTINGS

Apply grease to zerk fittings (item 3) at clutch and at blower flange U-joints every 100 operating hours

**Note:** HydraMaster flexible drive shaft assemblies have two universal joints, one on either end of the drive shaft. The above mentioned lubrication interval refers to both universal joints.

# Troubleshooting

CDS 4.2 / 4.7

Section 10-6

No	Problem / Possible Cause	Solution
<b>1</b>	<b>The radiator overflows.</b>	
1.1	The CDS <i>heat exchanger</i> has developed an interior leak.	Test each heat exchanger separately with pressurized water or air. Replace the bad one.
1.2	The <i>radiator cap</i> is faulty.	Test the cap for pressure. Replace it if necessary.
1.3	The engine is overheating because the <i>engine thermostat</i> is malfunctioning.	See an authorized dealer to check the engine thermostat for proper operation. Replace it if necessary.
1.4	The engine is overheating because the <i>engine water pump</i> is malfunctioning.	At the heater core, remove the return line from the heat exchanger to the heater core. Remove the radiator cap and hold the hose in the radiator. Replace the water pump if the water volume is below five gallons per minute at the van's idle speed.
1.5	The engine is overheating because the <i>engine fan clutch</i> is slipping or not engaging.	See an authorized dealer to check the fan clutch and replace it if necessary.
1.6	<b>In Fords only</b> , the engine is overheating because the <i>oxygen by-pass relay</i> is missing or not working properly.	There should be + 12 volts present on both oxygen by-pass relay contacts 30 and 87a with the van engine running and the CDS off. However there should be + 12 volts present only on one of the oxygen by-pass relay contacts 30 or 87a with the van engine running and the CDS on. Replace the relay if necessary.

No	Problem / Possible Cause	Solution
<b>2</b>	<b>The van engine sputters, then dies.</b>	
2.1	In 1992 and 1993 Fords, there can be a loss of <i>fuel pressure</i> to the fuel injectors after the CDS has run for an hour or more.	See an authorized dealer to inspect the fuel pump in the gas tank.
2.2	The <i>van engine</i> is in need of a tune up.	See an authorized dealer.
2.3	The <i>van</i> is overheating.	Please refer to Problems 1.3 - 1.6 in this chapter. Also see an authorized dealer.



No	Problem / Possible Cause	Solution
<b>3</b>	<b>When the CDS is turned on, nothing happens.</b>	
3.1	A <i>circuit breaker</i> is blown.	<ul style="list-style-type: none"> <li>a. Replace the weak breaker.</li> <li>b. There is a short in the wiring. See 3.3 in this chapter.</li> </ul>
3.2	The <i>fuse link</i> is blown.	<ul style="list-style-type: none"> <li>a. Replace the link.</li> <li>b. There is a short in the wiring between the battery and breaker. See 3.3 in this chapter.</li> </ul>
3.3	There is a short in the <i>system</i> .	Unplug each individual wire, one at a time (ie. the clutch, the horn circuit), until the breaker does not blow. Replace the shorted wire or part. See Electrical, Chapter 9.
3.4	There is a bad <i>ignition switch</i> .	With the key in the "ON" position, test the switch with a V.O.M. or a 12 V.D.C. test light for voltage on the accessory or ignition post. If there is no voltage, replace the switch.
3.5	There is a bad <i>ground wire connection</i> .	Check all the grounds wires. Make sure all of the connections are secure. Ground wires are white in color.
3.6	The <i>recovery tank</i> is full of water.	Empty all the water from the recovery tank.
3.7	There is a bad <i>float in the recovery tank</i> .	Disconnect one of the wires on the recovery tank float switch and turn the CDS on. If the unit starts with the float disconnected then replace the defective float.

No	Problem / Possible Cause	Solution
3.8	The Vanguard light comes on because a sensor is sending a signal to the control unit.	<p>Check each individual sensor. Determine if the sensor is sending a true signal or if the sensor is defective.</p> <p><b>Example:</b> If it is determined that the oil pressure switch is signaling the control unit it must be determined if the van engine is in fact lacking sufficient oil pressure.</p> <p><b>Note:</b> The CDS heat exchangers need to be grounded will for the conductivity sensor to function properly. If the conductivity sensor is shutting the unit down, first ground the heat exchangers and then retest the installation.</p> <p><i>(See the CDS Owner's Manual page 9-1 for proper sensor function.)</i></p>
3.9	The control unit is defective.	<p>To check, remove the control box from the CDS dash assembly with the wires still connected. Verify that the control unit has 12 vdc going to the positive terminal and to the common terminal.</p> <p>Disconnect the green/white wire from input 2 and the blue wire from input 1. Disconnect the orange/white wire from the terminal labeled "Probe" and connect a ground wire to this terminal. If the system does not work with the control unit wired in this manner, replace the control box.</p>

No	Problem / Possible Cause	Solution
4	<b>The tachometer bounces.</b>	
4.1	There is a bad <i>ground wire connection</i> on the sensor or the gauge.	Check the ground wires to make sure all of the connections are secure and clean.
4.2	The <i>gauge</i> is bad.	Check the wires going to the gauge for cuts, abrasions and bad connections. With the CDS ignition on, the red wire should have +12 volts on it. The black wire should have a ground common to the sensor ground and the white wire should go to the sensor. Replace the gauge if necessary.
4.3	The <i>sensor</i> is bad.	Disconnect the wire going to the sensor. Using a volt-OHM meter, check the resistance from ground to the wire going to the sensor. The resistance should be 410 to 450 OHMs. Replace the sensor if necessary.

No	Problem / Possible Cause	Solution
<b>5</b>	<b>The engine RPM is too high or too low.</b>	
5.1	The <i>vacuum throttle booster cable</i> is stretched or broken.	Replace the cable and readjust the pods. See your nearest HydraMaster Service Center.
5.2	The <i>vacuum throttle booster</i> (pod) is out of adjustment.	Readjust the pods. See your nearest HydraMaster Service Center.
5.3	The <i>vacuum solenoid</i> is bad.	The vacuum solenoid is normally a closed valve. The valve will open to allow vacuum through when 12 volts are present across its terminals. Replace the solenoid if necessary.
5.4	The <i>vacuum hose</i> going to the solenoid valve or throttle booster is clogged, pinched or cut.	Replace the hose.
5.5	The <i>vacuum throttle cable</i> is catching on something.	Replace the cable or add a protective cover.
5.6	The vacuum solenoid is not getting <i>power</i> .	Trace the wiring and locate the electrical problem.
5.7	The <i>vacuum throttle booster</i> does not engage.	Check the vacuum at your vacuum hose. If there is vacuum but the pod does not engage, replace the vacuum pod.

<b>No</b>	<b>Problem / Possible Cause</b>	<b>Solution</b>
<b>6</b>	<b>The van engine is overheating.</b>	
6.1	See Problems 1.3 - 1.6 in this chapter.	

No	Problem / Possible Cause	Solution
<b>7</b>	<b>The front end clutch will not work.</b>	
7.1	The <i>recovery tank</i> is full.	Empty the tank.
7.2	The <i>float switch</i> in the recovery tank is defective.	When the float is down, the circuit is open. When the float is up, the circuit is closed. If necessary replace the switch.
7.3	There is no <i>power</i> getting to the clutch.	Locate any burnt, broken, or cut wire and repair as necessary.
7.4	The <i>clutch</i> is burnt and slipping.	See Problem 9 in this chapter.

No	Problem / Possible Cause	Solution
8	The pump clutch will not work.	
8.1	The <i>pump clutch switch</i> has failed.	Replace the switch.
8.2	The <i>lower float switch</i> in the mix tank is defective.	When the float is down, the circuit is open. When the float is up, the circuit is closed. Replace the switch if necessary.
8.3	There is no <i>power</i> getting to the clutch.	Locate any burnt, broken, or cut wire and repair as necessary. Also check for and repair any loose connection.
8.4	There is a bad <i>ground</i> .	Check the blower frame ground connection. Repair as necessary.
8.5	The <i>clutch</i> has failed.	Replace the clutch.

No	Problem / Possible Cause	Solution
<b>9</b>	<b>The clutch is burnt and slipping.</b>	
9.1	The <i>clutch housing</i> is defective (bad bearings or worn shaft).	This allows the clutch pulley to rub on the coil of the clutch. Replace the clutch housing. And, if the clutch is burnt, replace it.
9.2	There is too much blower load due to excessive <i>vacuum</i> .	Clean and adjust the vacuum relief valve. Readjust the vacuum to be 12 Hg when under a full load. Replace the clutch.



No	Problem / Description	Solution
10	Problems with the drive shaft.	
10.1	The drive shaft vibrates.	Vibration is usually caused from one of the following: a. A bent shaft. If this is the cause, replace the shaft. b. An excessive amount of the splined shaft is exposed. If the exposed shaft is over 4 inches, remount the blower closer to the engine. c. The bearings in the clutch housing are worn. If this is the cause, replace the bearings and clutch housing shaft. d. The universal joints are worn out. If this is the cause, replace the shaft. e. The blower is out of alignment. If the blower is more than 3° out of alignment with the van engine, the universal joints on the drive shaft fight each other. This causes the vibration. If necessary, reinstall the blower.
10.2	The drive shaft is broken.	Replace the shaft.
10.3	The drive shaft is rattling.	Remove the splined shaft and grease.
10.4	The drive shaft is rubbing on the safety ring.	This is usually caused by the deterioration of the motor mount on the passenger side. Inspect the engine motor mounts and replace them as necessary.

No	Problem / Possible Cause	Solution
11	In Fords only, the insulator spacer on the radius arm is deteriorated (passenger side).	
11.1	The <i>heat shield</i> is not in place.	Install a shield, auxiliary fan and oxygen by-pass relay.
11.2	There is a problem with the <i>radius arm</i> .	Repair or replace the arm.

No	Problem / Possible Cause	Solution
<b>12</b>	<b>The van starter is burnt or not working.</b>	
12.1	The <i>starter blanket</i> is missing.	Inspect the starter. Replace the missing blanket if necessary.
12.2	The <i>auxiliary fan</i> is not working.	Inspect the fan and replace if necessary.
12.3	<b>On Fords</b> , the <i>oxygen by-pass relay</i> is not working.	There should be +12 volts present on both oxygen by-pass relay contacts 30 and 87a with the van engine running and the CDS <b>off</b> . However there should be +12 volts present only on one of the oxygen by-pass relay contacts 30 or 87a with the van engine running and the CDS <b>on</b> . Replace the relay if necessary.
12.4	The <i>starter motor</i> is defective.	Replace the starter and install a starter blanket if it is not already equipped.
12.5	The <i>starter solenoid</i> is defective.	Remove and test the solenoid. Replace it if necessary.
12.6	The <i>battery</i> is dead.	Charge the battery.
12.7	The <i>RPMs</i> are too high.	See Problem 5 in this chapter.

No	Problem / Possible Cause	Solution
13	The cleaning water is too cold.	
13.1	Too much <i>water</i> is being moved.	Measure the water output with an 8006 jet installed. Your output at 300 PSI should be less than 1.5 GPM. If the flow is more than 1.5 GPM, the temperature will be low. To achieve maximum efficiency with your heat exchangers the water flow must not be continuous. A ten seconds "on" and ten seconds "off" pattern will keep the temperature at maximum.
13.2	The incoming <i>water temperature</i> is extremely low.	Insulate the incoming garden hose.
13.3	The <i>heat exchangers</i> are clogged with hard water deposits.	Remove the fittings on the cleaning water end of the heat exchangers and inspect for hard water deposits. If the heat exchangers have deposits, they must be cleaned or replaced.
13.4	The <i>water hose</i> is kinked somewhere from the van engine to the heat exchangers.	Inspect both of the hoses going to the heat exchangers from the engine compartment. Repair or replace as required.
13.5	The <i>van engine thermostat</i> is bad.	Check the "Engine Temperature" gauge located on the van instrument panel. If it reads "Cold" or below "Normal" have the thermostat replaced.

No	Problem / Possible Cause	Solution
13.6	The <i>engine water pump</i> is bad.	Check the water flow going to and from the heat exchangers. (See Problem 1.4 in this chapter.) If the water flow is bad then replace the water pump. <b>NOTE:</b> The water pump must match model and year exactly.
13.7	The <i>water hoses</i> from the engine to the heat exchangers are plumbed backwards.	Reroute the hoses correctly.
13.8	The <i>high pressure water hoses</i> are plumbed wrong.	Reroute the hoses correctly.
13.9	The <i>shut off valve</i> is malfunctioning.	Repair or replace the valve.
13.10	The <i>radiator</i> is plugged.	Remove the radiator. At a radiator shop, give it a hot tank treatment.
13.11	The <i>heater core</i> is restricted or plugged.	See Authorized HydraMaster Dealer.

No	Problem / Possible Cause	Solution
14	<b>The water pump is pulsing.</b>	
14.1	The hoses are restricted due to <i>hard water deposits</i> and/or <i>chemical build-up</i> .	Descale the machine.
14.2	The <i>throb hose</i> is hardened due to age or heat and cannot absorb spikes.	Replace the throb hose.
14.3	The <i>inlet hose</i> is drawing air.	Reseal the fittings. Tighten the hose clamps. Or replace the hose.
14.4	The <i>valves</i> are obstructed.	Clean or replace the valves.
14.5	There is a pin hole in one or more of the <i>diaphragms</i> , small enough to lose the prime but not to leak any oil into the water or water into the oil.	Replace all of the diaphragms. One could be replaced temporarily, however all should be replaced.
14.6	The <i>valve spring</i> is broken.	Replace the valves.

## CDS 4.2/4.7 MAINTENANCE LOG

MAX HRS	DAILY SERVICE	OIL RECOMMENDATIONS					
8	ENGINE OIL check	BLOWER	40 weight non-detergent				
8	GARDEN HOSE SCREEN clean	PUMP	5 - 30 weight synthetic motor oil				
8	MACHINE general inspection	ENGINE	See the van's Owner's Manual for oil recommendations.				
8	VAC TANK FILTER BAG clean						
8	BLOWER INLET spray with lubricant						
	WEEKLY SERVICE	DATE & HOURS					
25	BLOWER check oil level						
25	PUMP OIL check						
25	DRIVE SHAFT SYSTEM tighten set screws						
25	BELTS & PULLEYS check for wear						
25	HIGH PRESSURE LINES check for chafing						
25	ENGINE COMP. FUEL LINE check for chafing						
25	ENGINE COMP. WIRING check for chafing						
25	CDS UNIT WIRING check for chafing						
25	NUTS & BOLTS check tightness						
25	VACUUM RELIEF VALVE inspect, clean, lube						
25	VACUUM TANK clean						
25	CHEMICAL SYSTEM flush with vinegar						
25	GAUGE RPMs check and adjust at blower						
	MONTHLY SERVICE						
100	ENGINE OIL change						
100	ENGINE AIR CLEANER clean						
100	BY-PASS VALVE grease piston and o-rings						
100	BATTERY WATER LEVELS check						
100	DRIVE SHAFT grease u-joints						
	QUARTERLY SERVICE (3 MONTHS)						
400	BLOWER OIL change						
400	PUMP OIL change						
400	BLOWER grease bearing						
	YEARLY TRUCK MAINTENANCE						
	COMPLETE TUNE-UP						
	COOLING SYSTEM flush (new anti-freeze)						
	TRANSMISSION FLUID change						

---

# *How to Order Parts*

*CDS 4.2 / 4.7*

*Section 11-1*

**T**o obtain a proper diagnosis of your malfunction, and to order warranty replacement parts or repairs, it is important that you proceed in the following manner:

## **WARRANTY PARTS ORDERS**

1. Call the local distributor where you purchased your equipment and ask for the Service Department.
2. Have the following information ready:
  - A. Equipment Model
  - B. Date of Purchase
  - C. Hours on the Unit
  - D. Unit Serial Number
  - E. Description of Malfunction
3. Once it has been determined which parts are needed to correct the problem with your machine, make arrangements with your distributor to either perform the repairs or ship the parts to you.

## **PARTS ORDERS**

Call your local distributor. In most instances, he either stocks or has access to parts through a regional service center.

## **EMERGENCIES**

If, for any reason, your distributor is unable to supply you with the necessary parts, he may call us and arrange for expedited shipping.



HydraMaster sells parts only through authorized distributors and service centers.

## **ONE FINAL NOTE**

Any questions you have regarding the warranty program should be directed to the Customer Service Department at (425) 775-7275, 8 a.m. to 5 p.m. Monday through Friday (PST).

We shall always endeavor to be fair in our evaluation of your warranty claim, and shall provide you with a complete analysis of our findings.

HydraMaster warranty covers only defective materials and/or workmanship for the periods listed. **Labor and/or diagnostic reimbursement is specifically excluded.**

---

# *Warranty Information*

*CDS 4.2 / 4.7*

*Section 12-1*

**T**o avoid misunderstandings which might occur between machine owners and manufacturer, we are listing causes of component failure that specifically voids warranty coverage. Such causes as listed below shall constitute **abuse or neglect**.

**BLOWER:** Failure to lubricate impellers daily with an oil based lubricant. Failure to lubricate bearings as recommended in blower manual. Failure to maintain proper oil levels in the blower. Failure to use the correct oil grade and viscosity as recommended in blower manual. Failure to properly maintain blower safeguard systems such as waste tank filter screen, vacuum safety relief valve and waste tank automatic shut-off system. Allowing foam to pass through blower.

**HIGH PRESSURE WATER PUMP:** Failure to maintain proper oil level as recommended in pump manual. Failure to change oil in pump at recommended intervals. Failure to protect pump against freezing. Failure to maintain pump protection shut-off system. Failure to use water softener in hard water areas. Use of improper chemicals.

**VAC TANK:** Failure to properly maintain filtering devices in tank. Failure to clean tank as recommended by manufacturer. Failure to maintain vacuum safety release in tank lid. Use of improper chemicals.

**CHEMICAL PROPORTIONER:** Use of improper chemical. Failure to use water softener in hard water area. Operating machine without proper chemical filter screen. Failure to protect against freezing.

**CONTROL PANEL:** Failure to protect flowmeter and water pressure gauge against freezing.

**VACUUM AND SOLUTION HOSES:** Failure to protect hoses against freezing. Failure to protect hoses against burns from engine/blower exhaust. Damage to

hoses from being run over by vehicles. Kinking or cracking from failure to store or unroll hoses correctly. Normal wear and tear from everyday use.

**CLEANING WAND:** Failure to protect against freezing. Obvious physical abuse of wand.

**WATER HEATING SYSTEM:** Over pressurization of the system (recommended maximum working pressure - 800 PSI). Failure to protect against freezing.

**HARD WATER DEPOSITS:** Failure to use or maintain a water softening system or a properly installed magnetic-type de-scaler with machine operating in designated "Hard Water Areas" (3.5 grains or more per gallon).

## **WARRANTY PROCEDURE**

Warranty coverage is available to you **ONLY** through HydraMaster Corporation, 11015 47th Avenue W, Mukilteo, WA 98275. When warranty parts are needed, write **HydraMaster Warranty Dept.** at the above address, or call the Warranty/Service Dept. at (425) 775-7275. **No collect calls will be accepted.** When calling, be sure to have machine information and serial number ready for the service representative. **Hours of Warranty/Service Dept. are 8:00 am to 5:00 pm Pacific Time.**

**IMPORTANT:** HydraMaster's warranty policy provides replacement parts without charge for thirty (30) days to customers maintaining current account status. An invoice will be sent to the customer for the amount of the parts sent. The customer's faulty parts **must be** returned for evaluation prior to the expiration of the thirty (30) day period. Upon warranty approval, a credit will be issued the customer for the replacement parts invoice. **Warranty disapproval or failure to return the faulty parts within the thirty (30) day period allowed will result in the customer being charged for the replacement parts sent.**

---

# Accessories

*CDS 4.2 / 4.7  
Section 13-1*

## **Genuine HydraMaster Accessories & Detergents**

**T**his section of your Owners Manual is devoted to Accessories and Detergents which we have found to be helpful and useful. *These products can enhance your cleaning and reduce your labor costs!*

HydraMaster Machine accessories are the most innovative collection available in the cleaning industry. Our patented **RX-20 Rotary Extractors** have changed the shape of steam cleaning. Our hoses and tanks are of the finest quality construction.

**SafeClean Detergents** have been specially prepared, not only to give you exceptional cleaning, but also to optimize your truckmount's operation and reliability. *Most detergents don't work well under the high heat, high pressure conditions of truckmount use.* **SafeClean** will maintain your machines's water pump and water heating systems at peak efficiency and help ensure fewer breakdowns.

***For more information, or to order Genuine  
HydraMaster Accessories and Detergents  
Call your nearest authorized HydraMaster Distributor.***

# **HYDRAMASTER**

Corporation  
6323 204th Street SW, Lynnwood, WA 98036

## **PRODUCT SUPPORT BULLETIN**

TO: All CDS Installers

DATE: 27 Oct 1992

RE: 1993 Chev Brake Lines

PSB #: 92102

Chevrolet cargo vans for 1993 have a new routing for their brake lines. They now travel directly over top of the transmission.

Caution is required when drilling the mounting hole on the passenger side of the blower frame. The brake lines can be lowered out of the way by unbolting two (2) mounting brackets that hold the lines in position.

The blower mounting bolt for this foot should go in from the bottom. Then the brake lines can be reattached.

# HYDRAMASTER

Corporation  
6323 204th Street SW, Lynnwood, WA 98036

## PRODUCT SUPPORT BULLETIN

TO: All HydraMaster Distributors      DATE: 14 Jun 1994

RE: '93 Dodge Vans      PSB #: 94062  
Location of Fuel Tanks

It has come to our attention that the fuel tanks on 1993 and newer Dodge vans are located directly against the floor of the van. Caution must be used when drilling any holes through the floor. The attached illustration indicates the area in the rear of the van where no screws may penetrate the floor.

Anyone who has installed flooring in a 1993 or newer Dodge van may need to check to see that no damage was done to the fuel tank. The fuel tanks are rotationally molded polyethylene plastic. If any holes were made in the tank they can be easily sealed with a hot knife. Please do not use an open flame.

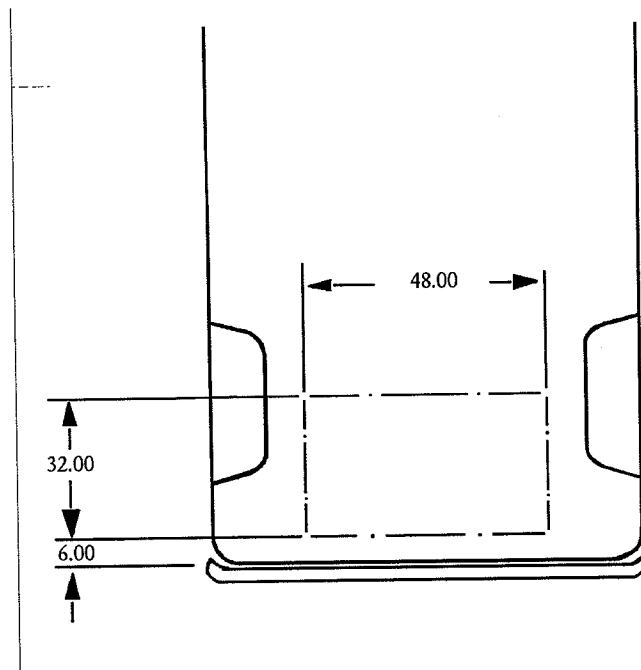

# **HYDRAMASTER**

---

Corporation  
6323 204th Street SW, Lynnwood, WA 98036

## **PRODUCT SUPPORT BULLETIN**

TO: All HydraMaster Distributors      DATE: 14 Jun 1994  
that Install Equipment

RE: Chevrolet CDS Installations      PSB #: 94063

This is just a reminder...

When installing CDS or slide-in units in Chevrolet vans, caution must be used while drilling holes through the floor.

There are two areas in which to be cautious. The brake lines, which travel up over the transmission, are close to the blower mounting location. (See Product Support Bulletin 92102.) Also behind the passenger seat, below the floor, is the ABS control unit.

Please check below the van before drilling any holes. This will minimize costly mistakes.

# **HYDRAMASTER**

Corporation  
6323 204th Street SW, Lynnwood, WA 98036

## **PRODUCT SUPPORT BULLETIN**

TO: All HydraMaster Distributors      DATE: 04 Apr 1995

RE: CDS Drive Shaft and Blower      PSB #: 95041  
Installation

HydraMaster would like to reemphasize the importance of proper drive shaft and blower alignment when installing CDS units. HydraMaster has experienced very good success with its flexible drive shaft technology. In order to maintain this fine record of reliability, standards of alignment during installation must be maintained.

According to the drive line manufacturer, input and output shafts must be at equal angles or, in other words, parallel with each other. When viewed from the side a typical van engine is three to five degrees off horizontal (see illustration on following page). This can be measured along the valve cover with an angle finder. This is also the angle of the input shaft, the shaft which extends off the back of the clutch housing. The blower shaft must be at this same angle. When viewed from the top the input shaft is parallel with the engine crank shaft. The blower shaft must be parallel with the engine crank also.

To achieve parallel shafts on Ford installations, spacers are required under the blower frame's front feet. On 1992 to 1995 gasoline engine Ford vans, two spacers are required under each leg. On 1985 to 1994 Ford diesel vans, four spacers are required on the leg on the driver's side and three spacers on the passenger's side. Chevrolet and Dodge installations require no additional spacers.

The blower frames are designed to sit on the van's floor, not on a raised plywood floor. Placing the rear of the blower frame on the plywood flooring may result in a misaligned drive shaft. A misaligned drive shaft may exhibit excessive vibration and result in reduced service life.

If you are not sure if the angles of the engine and blower match, an inexpensive angle finder gauge would be a good investment. If you can not locate one in your area, contact HydraMaster.



**Product Support Bulletin No. 95041...**

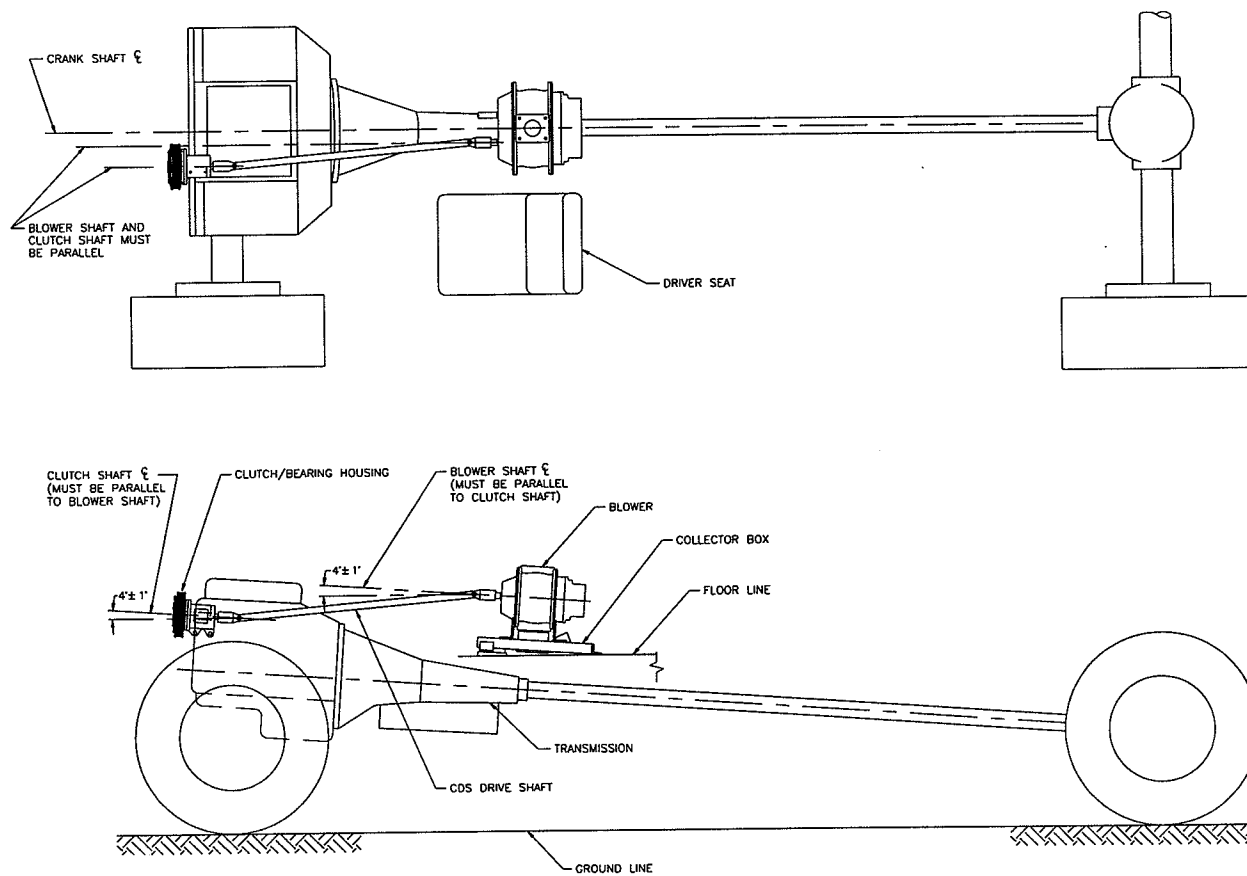

The drive shaft's recommended lubrication interval is now 400 hours. HydraMaster recommends that you lubricate with grade 2 bearing grease.

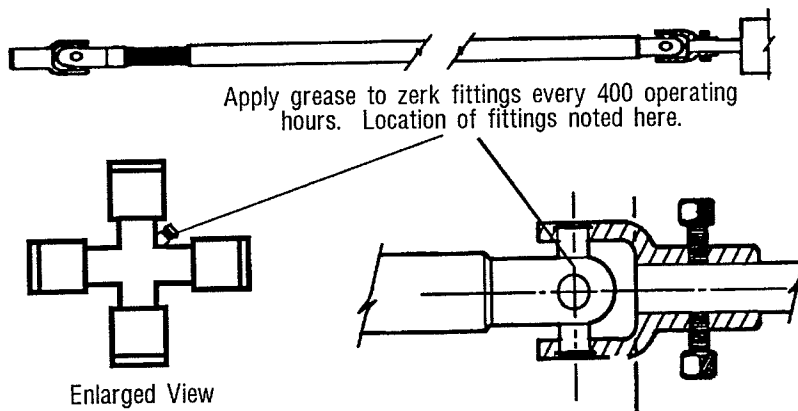

# HYDRAMASTER

Corporation  
11015 47th Avenue W, Mukilteo, WA 98275

## PRODUCT SUPPORT BULLETIN

TO: HM Distributors

DATE: 11 Jun 1998

RE: CDS Maintenance and Wear

PSB #: 98061

### The "Wear Effect" of a CDS on Its Host Vehicle

**Fiction:** It is sometimes said, usually by those promoting competitive systems, that each hour on the CDS hour meter is equivalent to running the vehicle at 50 mph, therefore 1,000 machine hours in a year would be equivalent to putting 50,000 miles on the vehicle. 15 years of experience teaches us that this calculation is inaccurate. In fact, *the "wear effect" of a CDS on the engine is less than 10 miles for each machine hour.*

**Fact\*:** History has proven that the engine of a CDS vehicle which is kept well lubricated and cooled, is typically able to transport the van over 100,000 miles on the odometer while also running the CDS System for 4 to 5,000 hours before any major engine work is required.

**Fact:** The CDS System's horsepower demand on the vehicle's engine is only a small percentage of the engine's capability. This low stress is a key to the excellent reliability and longevity of the engine system.

**Fact:** The light payload weight of the CDS when compared to other machines, puts less wear on the vehicle's other systems (i.e. brakes, differential, drive line, transmission, suspension, body, etc.). The lighter weight also contributes to improved gas mileage during transportation.

\*Hours and miles are based upon actual reports. They do not constitute a guarantee and do not in any way modify the standard warranties of the vehicle or the CDS System.