



Titan 575 Owner's Manual

HydraMaster
11015 47th Avenue West
Mukilteo, Washington 98275

MAN-44326 Rev. 0, September 1, 2011
(182-576-D)

No part of this manual may be reproduced or used in any form or by any means (i.e. graphic, electronic, photocopying or electronic retrieval systems) without the express written permission of HydraMaster. Specifications and information in this document are subject to change without prior notice. All rights reserved. © 2011 HydraMaster

Table of Contents

GENERAL INFORMATION	SECTION 1
System Concept.....	1-3
Contact Information.....	1-4
Warnings, Cautions and Notices.....	1-5
Responsibilities.....	1-9
Machine Specifications.....	1-12
Optional Equipment.....	1-14
Spare Parts.....	1-15
High Altitude Operation.....	1-17
Local Water Precautions.....	1-17
INSTALLATION INFORMATION	SECTION 2
Operating the Titan 575 In Hot Weather.....	2-2
Setting Up the Titan 575.....	2-5
Orientation of Fuel Pump.....	2-6
CLEANING INFORMATION	SECTION 3
Precautions.....	3-1
Preparing the Carpet for Extraction.....	3-2
Rinse and Recover.....	3-2
Overwetting.....	3-3
Streaking.....	3-3
Cleaning Tool Tips.....	3-4
Severe Cleaning Situations.....	3-8
OPERATING INSTRUCTIONS	SECTION 4
Setting the Temperature.....	4-3
Start-up Procedure.....	4-4
Setting the Pressure (for Optional High Pressure Washing Kit).....	4-5
Shut Down Procedure.....	4-7
MACHINE MAINTENANCE	SECTION 5
Operational Maintenance.....	5-2
Overall Machine Maintenance.....	5-4
Engine Maintenance.....	5-5
High Pressure Pump Maintenance.....	5-8
Vacuum System Maintenance.....	5-17
Descaling Procedure (Required).....	5-18
Freeze Guarding.....	5-19

TITAN 575

WATER AND CHEMICAL SYSTEM	SECTION 6
ELECTRICAL SYSTEM.....	SECTION 7
Electrical System Information.....	7-1
SYSTEMS TROUBLESHOOTING	SECTION 8
Heating System.....	8-2
Chemical System	8-3
Engine	8-4
High Pressure System	8-7
Vacuum System	8-9
ASSEMBLIES AND PARTS LISTS.....	SECTION 9
Machine Assembly Parts List	9-2
Frame Assembly Parts List	9-11
Engine Assembly Parts List	9-15
Exhaust Assembly Parts List	9-16
Top Cover Assembly Parts List	9-17
Flywheel Plate Assembly Parts List	9-19
Upper Dash Assembly Parts List	9-21
Electrical Panel Assembly Parts List	9-24
Blower Assembly Parts List.....	9-26
Pump and Silencer Assembly Parts List	9-27
Pump Assembly Parts List	9-30
Water Box Assembly Parts List	9-32
Lower Dash Assembly Parts List.....	9-35
Side Cover Assembly Parts List.....	9-36
Grill Assembly Parts List	9-37
Blower Heat Exchanger Assembly Parts List.....	9-40
Coolant Heat Exchanger Assembly Parts List.....	9-41
Diverter Valve Box Assembly Parts List	9-42
By-Pass Valve Assembly Parts List.....	9-43
3-Way Valve Assembly Parts List.....	9-44
Actuator Valve Assembly Parts List.....	9-45
Hi Pressure Manifold Assembly Parts List	9-46
70 Gallon Universal Recovery Tank Assembly Parts List.....	9-48
100 Gallon Universal Recovery Tank Assembly Parts List.....	9-50
70 Gallon Universal Recovery Tank for	
85 Gallon Rotomolded Tank Assembly Parts List	9-54
100 Gallon URT for 85 Gallon Rotomolded Tank Assembly Parts List ...	9-58
High Pressure Washing Kit - Pump Assembly Parts List	9-60
High Pressure Washing Kit - Lower Left Dash Assembly Parts List	9-61
Recovery Tank Cover with 2 1/2" Port Kit Assembly Parts List.....	9-63
Hose Routings.....	9-64

TITAN 575

HOW TO ORDER PARTS	SECTION 10
Warranty Parts Orders	10-1
Parts Orders.....	10-1
Emergencies	10-1
WARRANTY INFORMATION	SECTION 11
Blower	11-1
High Pressure Water Pump	11-1
Vacuum Tank	11-1
Chemical System	11-1
Control Panel	11-1
Vacuum and Solution Hoses	11-2
Cleaning Wand and Tool	11-2
Water Heating System	11-2
Hard Water Deposits.....	11-2
Warranty Procedure	11-2
ACCESSORIES AND CHEMICAL SOLUTIONS.....	SECTION 12

List of Figures

Figure 1-1. Hard Water Map of Mainland United States.....	1-18
Figure 2-1. Location of Roof Vents in Vehicle	2-1
Figure 2-2. Recommended Location of Titan 575 in Van	2-3
Figure 2-3. Install Fuel Pump, Outlet Side Up.....	2-6
Figure 2-4. Fuel Pump Must Be in Vertical Position	2-6
Figure 4-1. Titan 575 Upper Dash Assembly.....	4-1
Figure 4-2. Titan 575 Lower Dash Assembly.....	4-2
Figure 4-3. Heat Selector Valve.....	4-3
Figure 4-4. Thermostat Dial.....	4-3
Figure 4-5. Location of Water Pressure Selector Valve	4-5
Figure 4-6. Location of Chemical System Switches	4-6
Figure 4-7. Location of Blower Lube Port on Lower Dash Assembly	4-7
Figure 5-1. Remove Valve Cap and Valve Assembly	5-9
Figure 5-2. Inspect Manifold and Old Valves.....	5-9
Figure 5-3. Replace Center Inlet Check Valve With Modified Check Valve.....	5-10
Figure 5-4. Apply Grease and Install Valves.....	5-10
Figure 5-5. Replace Valve Cap and Torque to 95 ft. lbs. (13 m kgs)	5-10
Figure 5-6. Separate Manifold from Crankcase.....	5-11
Figure 5-7. Seal Assemblies May Come Off with Manifold.....	5-11
Figure 5-8. Examine Ceramic Plungers.....	5-11
Figure 5-9. Remove Stainless Steel Plunger Bolt and Ceramic Plunger	5-12
Figure 5-10. Install O-ring, Apply Sealant and Slide Plunger over Plunger Guide	5-12
Figure 5-11. Extract Retainers and Seals.....	5-13
Figure 5-12. Seal Kit and Insertion Tool for Seal Installation.....	5-14
Figure 5-13. Install Seal Assembly Using O-Ring Grease.....	5-14
Figure 5-14. Install Retainers into Cavities.....	5-15
Figure 5-15. Press Low Pressure Seal Assembly into Cavity.....	5-15
Figure 5-16. Re-install Manifold and Torque Fasteners.....	5-16
Figure 5-17. Torque Sequence in “X” Pattern.....	5-16
Figure 5-18. Torque Bolts to 22 ft. lbs (3 m kgs).....	5-16
Figure 5-19. Recirculation Fitting.....	5-18

Figure 6-1. Annotated Water, Chemical and Solution Flow Diagram - View 1 of 3	6-3
Figure 6-2. Annotated Water, Chemical and Solution Flow Diagram - View 2 of 3	6-4
Figure 6-3. Annotated Water, Chemical and Solution Flow Diagram - View 3 of 3	6-5
Figure 6-4. Water, Chemical and Solution Flow Diagram - Larger View	6-6
Figure 6-5. Chemical Flow Diagram - Larger View.....	6-7
Figure 6-6. Exhaust Flow Diagram.....	6-8
Figure 7-1. Electrical Schematic.....	7-2
Figure 7-2. Wiring Diagram - View 1 of 3	7-3
Figure 7-3. Wiring Diagram - View 2 of 3	7-4
Figure 7-4. Wiring Diagram - View 3 of 3	7-5
Figure 9-1. Machine Assembly - View 1 of 4	9-2
Figure 9-2. Machine Assembly - View 2 of 4	9-3
Figure 9-3. Machine Assembly - View 3 of 4	9-4
Figure 9-4. Machine Assembly - View 4 of 4	9-5
Figure 9-5. Frame Assembly - View 1 of 5	9-6
Figure 9-6. Frame Assembly - View 2 of 5	9-7
Figure 9-7. Frame Assembly - View 3 of 5	9-8
Figure 9-8. Frame Assembly - View 4 of 5	9-9
Figure 9-9. Frame Assembly - View 5 of 5	9-10
Figure 9-10. Engine Assembly - View 1 of 3.....	9-12
Figure 9-11. Engine Assembly - View 2 of 3.....	9-13
Figure 9-12. Engine Assembly - View 3 of 3.....	9-14
Figure 9-13. Exhaust Assembly.....	9-16
Figure 9-14. Top Cover Assembly	9-17
Figure 9-15. Flywheel Plate Assembly	9-18
Figure 9-16. Upper Dash Assembly.....	9-20
Figure 9-17. Electrical Panel Assembly - View 1 of 2.....	9-22
Figure 9-18. Electrical Panel Assembly - View 2 of 2.....	9-23
Figure 9-19. Blower Assembly.....	9-25
Figure 9-20. Pump and Silencer Assembly	9-27
Figure 9-21. Pump Assembly - View 1 of 2	9-28
Figure 9-22. Pump Assembly - View 2 of 2	9-29
Figure 9-23. Water Box Assembly	9-31
Figure 9-24. Lower Dash Assembly - View 1 of 2.....	9-33
Figure 9-25. Lower Dash Assembly - View 2 of 2.....	9-34
Figure 9-26. Side Cover - Machine Assembly	9-36
Figure 9-27. Grill Assembly	9-37
Figure 9-28. Blower Heat Exchanger Assembly - View 1 of 2	9-38
Figure 9-29. Blower Heat Exchanger Assembly - View 2 of 2	9-39

TITAN 575

Figure 9-30. Coolant Heat Exchanger Assembly.....	9-41
Figure 9-31. Diverter Valve Assembly	9-42
Figure 9-32. By-Pass Valve Assembly.....	9-43
Figure 9-33. 3-Way Valve Assembly.....	9-44
Figure 9-34. Actuator Valve Assembly.....	9-45
Figure 9-35. Hi Pressure Manifold Assembly	9-46
Figure 9-36. 70 Gallon Universal Recovery Tank (URT) Assembly.....	9-47
Figure 9-37. 100 Gallon Universal Recovery Tank Assembly	9-49
Figure 9-38. 70 Gallon URT for 85 Gallon Rotomolded Tank Assembly - View 1 of 3	9-51
Figure 9-39. 70 Gallon URT for 85 Gallon Rotomolded Tank Assembly - View 2 of 3	9-52
Figure 9-40. 70 Gallon URT for 85 Gallon Rotomolded Tank Assembly - View 3 of 3	9-53
Figure 9-41. 100 Gallon URT for 85 Gallon Rotomolded Tank Assembly - View 1 of 3	9-55
Figure 9-42. 100 Gallon URT for 85 Gallon Rotomolded Tank Assembly - View 2 of 3	9-56
Figure 9-43. 100 Gallon URT for 85 Gallon Rotomolded Tank Assembly - View 3 of 3	9-57
Figure 9-44. High Pressure Washing Kit - Pump Assembly	9-59
Figure 9-45. High Pressure Washing Kit - Lower Left Dash Assembly	9-61
Figure 9-46. Recovery Tank Cover with 2 1/2" Port Kit Assembly	9-62

1- General Information

The compact but powerful Titan™ 575 is a carefully re-engineered truckmount carpet cleaning machine designed and manufactured by HydraMaster. A WG 972 Kubota engine now powers the 575's Tuthill 4007 Tri-Lobe vacuum blower and the high pressure water pump, which is rated at 4 gpm (15 litres/minute).



In keeping with HydraMaster's corporate philosophy to meet new lower emission requirements, HydraMaster has re-designed the Titan 575 around the Kubota engine which complies with two of the strictest emission regulations: EPA Phase3 and CARB Tier3.

The Titan 575's innovative design features include a blower/engine exhaust diverter which allows for a non-recirculating or "dump-less" subsystem. This dump-less system, a first in the carpet cleaning industry, reduces the need to refill the fresh water tank or empty the recovery tank.

TITAN 575

Other features of the Titan 575 are:

- Dual oil bath and sight glasses for enhanced blower reliability
- 0 - 1,200 psi (0 - 8,274 kPa) heated for carpet and tile cleaning
- Optional 2,000 psi (13,790 kPa) pressure washing kit
- Dual tool/wand capable
- A.D.C temperature control with instant heat up to 265° F (129.4° C)
- Optional Dura-Flow Automatic Pump Out (APO)
- Optional 85 gallon Fresh Water Tank Mounting Kit

The Titan 575 can be mounted onto a HydraMaster 85 gallon (322 litre) Rotomolded Fresh Water Tank. You can also select either the HydraMaster 70 gallon (265 litre) recovery tank, which comes in the standard equipment package, or a 100 gallon (379 litre) recovery tank, offered as an option.

This Owner's Manual contains installation and operation instructions as well as information required for proper maintenance, adjustment and repair of the Titan 575. Component troubleshooting guides have also been included for your convenience.

It is the purpose of this manual to help you properly understand, maintain and service your Titan 575. Follow the directions carefully and you will be rewarded with years of profitable, trouble-free operation.

It is imperative that no section of this manual be overlooked when preparing for operation of the Titan 575. Please read the manual to familiarize yourself with the operation of your Titan 575, paying special attention to all **Warnings and Cautions**.

This section of the manual contains the following information:

- Contact Information
- Warnings, Cautions and Notices
- Machine Specifications
- Responsibilities
- Local Water Precautions

NOTICE

Photographs and illustrations included in this document can represent optional equipment as well as standard equipment.

TITAN 575

SYSTEM CONCEPT

This is how the Titan 575 works:

1. Incoming water enters the water box and is pressurized by the high pressure water pump. The water is heated by engine coolant in the tube and shell heat exchanger and then by the engine and blower exhaust in the cross flow heat exchanger.
2. Cleaning solution is then injected into the pressurized water stream and the heated solution is delivered to the cleaning tool.
3. The solution is recovered by the vacuum generated by the vacuum pump and is collected in the recovery tank for proper disposal.

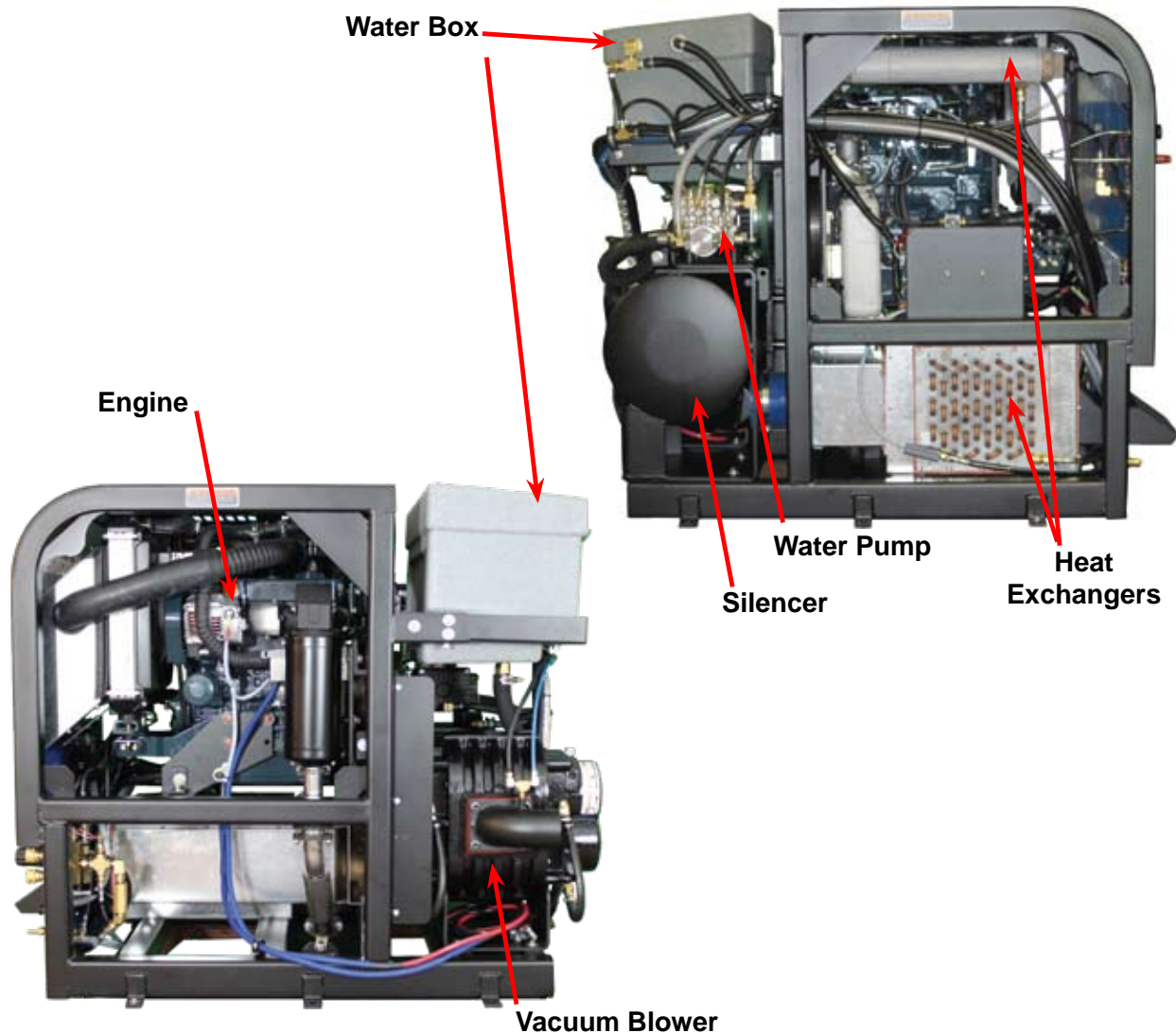

TITAN 575

CONTACT INFORMATION

If you have any questions regarding the operation, maintenance or repair of this machine, please contact your local distributor.

To find a local distributor, please visit our website at <http://hydramaster.com/HowToBuy/DealerLocator.aspx>

If your question cannot be resolved by your distributor or by the information within this manual, you may contact HydraMaster Customer Service direct using the following phone numbers.

<u>Hours</u>	<u>Telephone Numbers</u>	<u>E-mail Addresses</u>
Monday-Friday	(425) 775-7275 Service	Tech Support: techsupport@hydramaster.com
7:00 a.m. to 5:00 p.m.	(425) 775-7276 Parts	Parts Support: parts@hydramaster.com
Pacific Standard Time	(425) 771-7156 Parts / Service FAX	

When calling your distributor, be sure to reference the serial number and date of purchase.

FOR YOUR REFERENCE:

Serial No. _____

Date of Purchase: _____

Purchased From (Distributor): _____

WARNINGS, CAUTIONS AND NOTICES

WARNING

HydraMaster uses this WARNING symbol throughout the manual to warn of possible injury or death.

CAUTION

This CAUTION symbol is used to warn of possible equipment damage.

NOTICE

This NOTICE symbol indicates that federal or state regulatory laws may apply, and also emphasizes supplemental information.

TITAN 575

Warnings and Cautions specific to the Titan 575 include the following:

⚠ WARNING

During the operation of the truckmount many components are in motion. Never touch any part of the truckmount that is in motion. Serious injury may result.

⚠ WARNING

During the operation of the truckmount many surfaces will become extremely hot. Never touch hot surfaces. Serious injury may result.

⚠ WARNING

The operation of this truckmount can produce noise levels exceeding 85 decibels to a distance of 10 ft (3.05 m). The Occupational Safety and Health Administration (OSHA) recommends the use of hearing protective equipment if a person is exposed to an average of 85 decibels over an 8-hour period. Check with local and state agencies concerning hearing conservation rules.

⚠ WARNING

During the operation of the truckmount carbon monoxide and other toxic fumes are produced. Position the vehicle so that any fumes produced will be directed away from inhabited areas and any points of building entry (doors, windows, air conditioning units, fans, etc.). Do not occupy the vehicle while the truckmount is in operation. Serious injury may result.

⚠ WARNING

During the operation of the truckmount, chemicals known to the State of California to cause cancer, birth defects and other reproductive harm are produced by the engine exhaust.

⚠ WARNING

Never operate the truckmount with a portable gas container inside the vehicle. Doing so will increase the risk of fire and explosion. Serious injury or death may result.

Transporting a vented fuel container that presently contains, or has ever contained in the past, a flammable liquid is strictly forbidden by HydraMaster and by federal and state regulations. Doing so will increase the risk of fire and explosion. Serious injury or death may result.

⚠ WARNING

Never smoke in or around the truckmount. Doing so will increase the risk of fire and explosion. Serious injury or death may result.

⚠ WARNING

During the operation of the truckmount the exhaust system will become extremely hot. Keep all flammable materials away from the truckmount exhaust system. Failure to do so will increase the risk of fire and explosion. Serious property damage may result.

CAUTION

Never operate the truckmount when the vehicle is tilted more than 10 degrees in any direction. Doing so will result in improper lubrication of the internal components, and will increase the risk of serious component or engine damage.

CAUTION

Never perform cleaning operations when the truckmount engine is running at the IDLE throttle position. Failure to do so will increase the risk of serious component or engine damage.

CAUTION

Never operate the truckmount with the vehicle doors closed. Doing so results in extremely high temperatures inside the vehicle and will lead to serious component or engine damage.

CAUTION

Never use concentrated acids or solvents (including d-limonene) in the truckmount water system or chemical system. Use of these products will cause serious component damage.

CAUTION

Never operate the truckmount with a water hardness reading measuring 3.0 grains per gallon (3.79 litres) or higher. Using reading than 3.0 grains per gallon (3.79 litres) will cause scale to build up inside the truckmount water system. Scale build up causes serious component damage. Test all water prior to use and use water softening equipment if necessary.

TITAN 575

CAUTION

Never allow water to freeze inside the truckmount. Serious component damage will occur. Perform all freeze guarding procedures outlined in this digital Owner's Manual.

CAUTION

Many vehicles have critical components mounted directly below the floor that can easily be damaged. Before drilling holes in the floor of the vehicle inspect the underside of the vehicle for critical components. Failure to do so may result in damage to the vehicle.

CAUTION

Use of the vacuum recovery system when stripping or otherwise removing wax from floors is specifically excluded as an approved use of the truckmount. Failure to follow this exclusion may lead to component failure and will invalidate your warranty.

CAUTION

Use of the vacuum recovery system for "dry cleaning", without corresponding solution application (i.e. duct cleaning), is specifically excluded as an approved use of the truckmount. Failure to follow this exclusion may lead to component failure and will invalidate your warranty.

CAUTION

If concentrated acids or solvents are used to pre-treat surfaces before power washing, do not recover them through the vacuum system. Failure to follow this exclusion may lead to component failure and will invalidate your warranty.

RESPONSIBILITIES

Purchaser's Responsibilities

- Prior to purchasing a van, ensure that the payload is suitable for all of the equipment that will be installed and transported. This includes and is not limited to: the truckmount, recovery tanks, fresh water tanks, on-board water, hose reels, hoses, cleaning tools, chemicals and drying equipment. Payload capacity information is available through the auto dealer, the manufacturer's web site, and is also located on the door pillar of the driver's side door.
- Purchase a heavy duty Group 24 (500+ CC Amps) battery for this truckmount. This is normally available from the installation dealer.
- Prior to dropping your van off at the distributor for the truckmount to be installed, have a spray-on bed liner applied to the floor such as Rhino Lining® or Line-X®.

NOTICE

Plywood and carpet are not recommended.

- Prior to operating the truckmount, read this manual in its entirety and familiarize yourself with the information contained here. Special attention should be paid to all ***Warnings and Cautions***.
- The distributor is responsible for the correct installation of the truckmount. The distributor is also responsible to train you in the correct and proper operation and maintenance of the truckmount.

NOTICE

Any modification of the truckmount may void the warranty.

TITAN 575

Distributor's Responsibility

Acceptance of Shipment

Before accepting the truckmount, check the following:

1. The truckmount should be free from any damage during shipping. Do not sign the delivery receipt until you have closely inspected the truckmount and noted any damage on the delivery receipt. Hidden damage may be present even if the box looks okay. It is recommended that the box be opened before you sign for the shipment.
2. Check the packing list and verify that all items are accounted for.

Installation Responsibilities

- Ensure proper payload capacity. It is the distributor's responsibility to verify that the equipment package does not exceed the vehicle capacity.
- Ensure installation of a safe fuel tap system and through-floor fittings as provided by HydraMaster.
- Ensure proper placement of the truckmount, recovery tank, fresh water tank, and accessories in the vehicle, and check that they are secured with bolts and back up plates. The distributor should verify that the owner is in agreement with the layout.
- Ensure proper connection of the fuel lines.
- Ensure proper connection and installation of the battery. Verify that the battery is in accordance with HydraMaster's recommendation.
- Check the pump, vacuum blower and engine oil levels prior to starting the truckmount.
- Start and run the truckmount and check that all systems function properly.
- Test all hoses, wands and other accessories for correct operation.
- Ensure timely return of the document package.

Training

The distributor should provide a thorough review of the operation manual with the purchaser along with instruction and familiarization in:

1. How all the truckmount's systems function.
2. All safety precautions and their importance.
3. How to correctly start and shut down the truckmount.
4. How to correctly clean with the truckmount.
5. Where and how often to check and change component oil levels.
6. Freezing damage and how to avoid it. This includes explaining proper freeze guarding procedures.
7. How to do basic troubleshooting of the truckmount.
8. Hard water damage and how to avoid it. This includes how to determine if hard water exists in your area and the installation and use of water softening systems.
9. The truckmount's warranty and warranty procedures.

TITAN 575

MACHINE SPECIFICATIONS

Frame Dimensions	26.0" W x 45" D x 39" H (66 cm x 114 cm x 99 cm)	
Weight	900 lbs (408 kg)	
Engine - WG 972 Kubota	Oil Type	5W-30 Synthetic
	Capacity	3.2 quarts (3.02 litres) when changing oil and filter
	Engine rpm	High - 3,000 rpm
		Idle - 1,500 rpm
	Fuel Consumption	1.6 gph (6.1 litres/hr)
Ignition	Keyless	
Vacuum Blower - Tuthill 4007 Competitor (Dual Splash Lubrication)	Oil Type Max. Vac. 12" Hg	PneuLube or other ISO 100 rating
	Gear End Capacity	Approx. 5.8 oz. (171.5 ml)
	Drive End Capacity	Approx. 4.7 oz. (139 ml)
	Blower rpm	3,000 rpm
Water Pump- General Pump	Oil Type	15W-40
	Capacity	14 oz (414 ml).
	Pump Rate	4.0 gpm (15 litres/minute)
	Pump rpm	1,700 rpm
Operating Pressure	0 - 1,200 psi (heated) (0 - 8,274 kPa)	0 - 2,000 (no heat) (0 - 13,790 kPa) *
Chemical System	Last Step Chemical Injection	
Heating System	Cross Flow Heat Exchanger	Copper Tube and Shell Heat Exchanger

* Pressure washing option

TITAN 575

Standard Equipment	High Pressure Solution Hose	1/4" High Temperature Lined/Vinyl Cover - 100 ft. (0.635 cm High Temperature Lined/Vinyl Cover -30.5 m)
	Vacuum Hose	2" Vacuum Hose - 100 ft. (5.08 cm Vacuum Hose - 30.5 m)
		1-1/2" Wand Whip Line - 10 ft. (3.81 cm Wand Whip Line - 3.05 m)
	Recovery Hose	10 ft (3.05 m).
	Water Box	Rotomolded 7 gallon (26.5 litres) capacity
	Recovery Tank	70 gallon Universal Tank (265 litre Universal Tank)
	Cleaning Wand/Tool	Stainless Steel S-bend
		Replaceable Grip
		Rebuildable Solution Valve
	Garden Hose	
	Chemical Jug	5 gallon (19 litres)
	Battery Box	
	Van Decal	
	Van Installation Kit	
	Owner's Manual (on CD) Owner's Guide (printed)	

TITAN 575

OPTIONAL EQUIPMENT

To better meet your business needs, HydraMaster offers several options that you can add to your basic Titan 575 system. The following shows the available options and the additional kits necessary to install the options. Refer to the following table before placing your order.

If you want this option:	Order this P/N:	
2.5" Vacuum Hose Adapter (100 Gallon Recovery Tank Only)	000-078-875 Kit, 2.5" 3-Port Hose and 000-041-466, Cover Assembly	
Automatic Pump Out (APO) without a Fresh Water Tank)	000-079-091 Pump, Dura-Flow APO (70 or 100 Gallon Tank)	
For APO options with an 85 Gallon Fresh Water Tank, see * below.		
Exhaust Through Floor	000-079-129 Titan 575 Exhaust Thru Floor 4" Kit	
High Pressure Washing	000-079-126 Titan 575 2,000 PSI Kit	
	000-079-123 High PSI Hose and Tool Kit	
* 85 Gallon Fresh Water Tank	000-159-118 85 Gallon Rotomold Fresh Water Tank (FWT)	
	000-079-125 Titan 575 to 85 Rotomold FWT Mounting Kit and then order one of these options:	
	If you want this option:	Order this P/N:
	APO w/Standard 70 Gallon Tank	000-079-091
	APO w/Optional 100 Gallon Tank	000-079-094

If you have questions or need assistance configuring your system, please contact your distributor.

NOTICE

The Titan 575 comes standard with an exhaust deflector to which a hose cannot connect. HydraMaster strongly recommends you purchase the Exhaust Thru Floor Kit which directs the hot air outside of the van, away from the machine. This kit is highly recommended for vans with barn doors.

SPARE PARTS

The following table, starting on this page and continuing on the following page, is a list of available Titan 575 spares that distributors may purchase to have on hand for repairs and maintenance.

Part No	Description	Qty
000-010-128	Belt, 9330HD Pump Drive	1
000-010-131	Belt, 3vx450 Eng. Drive	3
000-025-003	Cable, Choke, With Detent	1
000-025-020	Cable, Throttle	1
000-046-011	Diaphragm, GP	1
000-049-002	Filter, Fuel	1
000-049-023	Filter, Garden Hose Screen	1
000-049-063	Filter, Air	1
000-049-256	Filter, Oil - Kubota	1
000-049-118	Filter, 1/4" NPT Chemical	1
000-049-152	Filter, Basket, Recovery Tank	1
000-049-153	Filter, Stainless Steel Vacuum Pump	1
000-052-050	Quick Connect, 440 Male	3
000-052-051	Quick Connect, 440 Female	2
000-052-052	Quick Connect, 660 Male	1
000-052-053	Quick Connect, 660 Female	1
000-056-011	Fuse, 30 Amp Circuit	2
000-057-177	Gasket, Exhaust Doughnut	1
000-073-011	Impeller, Replacement, APO	1
000-074-025	Gauge, Vacuum 0-30" Hg	1
000-074-032	Meter, Chemical Flow	1
000-074-125	Controller, Temperature	1
000-074-167	Gauge, Pressure 0-3,000 Psi	1
000-078-005	Kit, By- Pass Valve Repair	1
000-078-005	Kit, Pressure Regulator Rebuild	1
000-078-019	Kit, H/M Solution Valve	1
000-078-521	Kit, Valve, 4.0 gpm General	1
000-078-522	Kit, Seal, 4.0 gpm General	1
000-087-006	HydraMaster-recommended Lubricant Blower Spray - part number is for 1 can	1 ea
000-149-039	Sender, Temperature	1
000-149-566	Sensor, RTD 6" 90°	1

TITAN 575

Part No	Description	Qty
000-157-022	Switch, Relay	2
000-157-040	Switch, 12V DC, On/Off	2
000-157-0801	Switch, Float with Polypropylene Barrel	1
000-157-152	Switch, Ignition, 3-Way	1
000-169-011	Valve, Thermal, Low Pressure	1
000-169-0171	Valve, 3-Way (Chemical)	1
000-169-022	Valve, 1 1/2" Full Port	1
000-169-160	Valve, 2-Way (Chemical)	1
000-169-184	Valve, Check, S/S Chemical Pump	2
000-169-213	Valve, 1/4" NPT 3-Way (Heat Selector)	1
000-169-216	Valve, Check, Chemical Pump	1
000-169-218	Valve, Water Box Inlet	1
000-169-219	Valve, Check, Chemical Differential	1

HIGH ALTITUDE OPERATION

Elevation plays a key role in how the truckmount will operate. Operation at high altitude (above 5,000 ft [1,524 m]) may require a high-altitude carburetor jet. Use of this jet at high altitude will improve power, reduce fuel consumption and help reduce excessive carbon build-up in the exhaust and heat exchanger systems.

Contact the local Kubota dealer or HydraMaster to obtain the proper jet size. Find your local Kubota dealer at http://www.kubotaengine.com/distributor/engine_usa.html.

LOCAL WATER PRECAUTIONS

The quality of water varies greatly. Many areas have an excess of minerals in the water which results in what is commonly called “hard water.” These minerals tend to adhere to the insides of heater coils and other parts of the machines causing damage and a loss of cleaning effectiveness. This influences the reliability and efficiency of equipment in direct proportion to the level of hardness.

Hard Water Advisory

HydraMaster recognizes that any hard water deposits which might occur within the water system of our truckmounts is a serious problem. The precision technology of truckmount heat exchanger systems is intolerant of any foreign material. Hard water deposits will ultimately decrease the performance of the system and are expected to seriously lower the reliability of the machine.

To validate a machine’s warranty, HydraMaster requires that all machines operating in designated “Hard Water Areas” (3.0 grains or more per gallon [3.79 litres]) be fitted with a water softening system, or a properly installed magnetic-type descaler must be used and maintained. Periodic descaling or acid-rinsing alone is not adequate in these areas. HydraMaster does not recommend any particular type or brand; however, the relative effectiveness of some types of magnetic descalers or softeners may require additional periodic use of descaling agents.

HydraMaster also recommends, in the strongest possible terms, that machines in all areas be fitted with a water softening system for improved operation and reliability.

CAUTION

Failure to take appropriate measures to prevent scale build up can result in system failure and loss of warranty on affected parts.

TITAN 575

Hard Water Area Map

The hard water map, shown in Figure 1-1, defines hard water areas in the continental United States which compromise fluid related components such as hoses, fittings, heaters, pumps, valves and water-cooled engines. For other countries, hard water area maps can be obtained from geological societies.

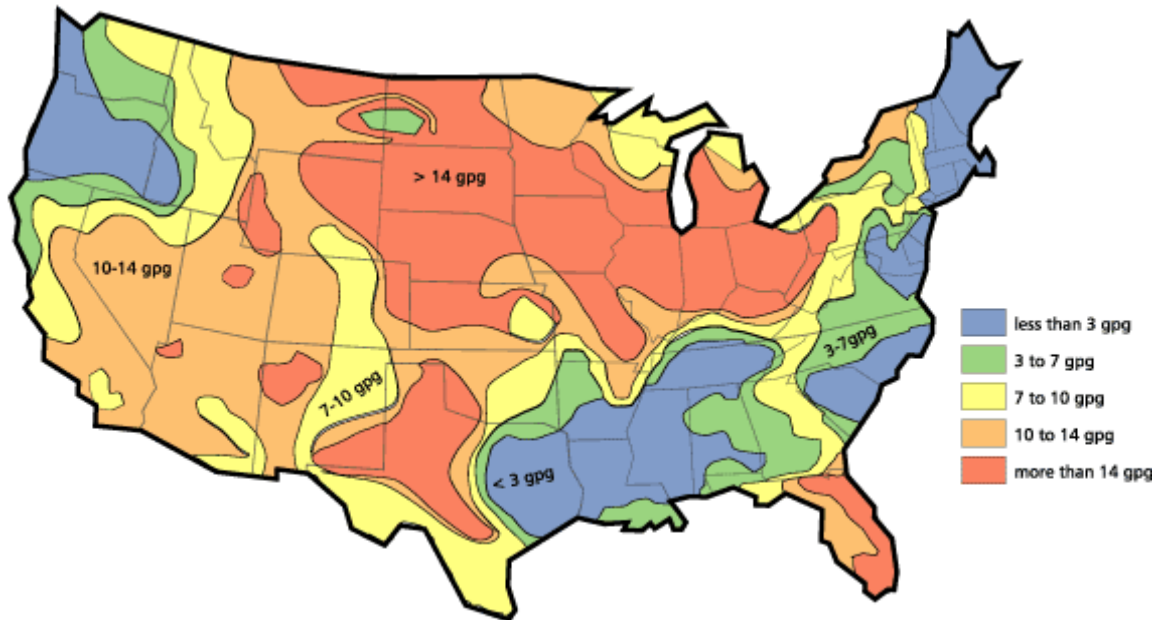

Figure 1-1. Hard Water Map of Mainland United States

NOTICE

The map shown in Figure 1-1 is provided for general reference only. Water hardness in your geographical location should be confirmed by testing.

Water Softener

Cleaning efficiency and equipment life is increased, chemical use decreased, and the appearance of cleaned carpets enhanced when water softeners are incorporated in hard water areas. HydraMaster strongly urges the use of water softener units with the Titan 575 in areas exceeding 3.0 grains per gallon.

Failure to use a water softener in these areas will invalidate the machine's warranty. Referring to the hard water area map shown Figure 1-1, determine the quality of water in your area and take immediate action if the water hardness exceeds 3.0 grains per gallon.

The relatively low cost of a water softener service is more than made up for by an increased life of machine parts, reduced chemical costs and continued cleaning efficiency. The water softener will also increase the effectiveness of the cleaning chemicals, therefore less chemical will be needed.

Contact a water softener distributor in your area for information on the rental of a simple water treatment unit to carry in your truck. Be sure to charge the water softener in accordance with the capability of the softener.

For example: If the softener will treat 900 gallons (3,406 litres) of water and the machine uses an average of 30 gallons/hour (113.5 litres/hour), for an average of 5 hours a day, this equals 150 gallons per day (568 litres/day). In 6 days the machine would use 900 gallons (3,406 litres) of water. Therefore, the softener would need to be charged every 6 working days for maximum softening.

TITAN 575

Waste Water Disposal Advisory

There are laws in most communities prohibiting the dumping of recovered “gray” water from carpet cleaning in any place but a sanitary treatment system.

The cleaning rinse water, recovered into your unit’s vacuum tank, contains materials such as detergents, and must be safely processed before entering streams, rivers and reservoirs.

In most cases, an acceptable method of waste water disposal is to discharge into a municipal sewage treatment system after first filtering out solid material such as carpet fiber. Access to the sanitary system can be obtained through a toilet, laundry drain, RV dump, etc. Permission should first be obtained from any concerned party or agency.

One disposal method which usually complies with the law is to accumulate the waste water and haul it to an appropriate dump site. Another solution to the disposal problem is to equip your Titan 575 with an Automatic Pump-Out System (APO). These systems are designed to remove waste water from the extractor’s recovery system and actively pump the water through hoses to a suitable disposal drain.

HydraMaster makes an APO System which can be ordered with new equipment or installed later.

When properly configured, the systems will continuously monitor the level of waste water and pump it out simultaneously with the cleaning operation. The hidden benefit of this process is that the technician does not have to stop his/her cleaning to empty the recovery tank.

NOTICE

IN ACCORDANCE WITH EPA, STATE AND LOCAL LAWS, DO NOT DISPOSE OF WASTE WATER INTO GUTTERS, STORM DRAINS, STREAMS, RESERVOIRS, ETC.

The penalties for non-compliance can be serious. Always check local laws and regulations to be sure you are in compliance.

2 - Installation Information

Although there are many different heavy duty vehicles used for carpet cleaning equipment, the preferable vehicle for a Titan 575 installation is a cargo van with a heavy-duty suspension package and a 3/4 HD ton capacity. If a fresh water tank is added, a one ton or larger capacity van is required.

Prior to installation of the Titan 575, HydraMaster recommends installing a spray-on bed liner in the vehicle. This provides 'metal to cushion' mounting rather than 'metal to metal' and makes for an attractive van interior.

HydraMaster also recommends installing roof vents in vehicles operated in hot weather locations. Roof vent positions are shown in Figure 2-1. Consult your local RV distributor about selection and/or installation of powered roof vents.

For best results, the fan should draw air into the vehicle which will supply cooler air to the air cleaner intake.

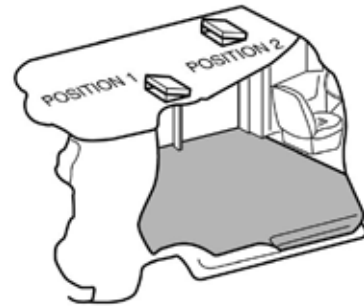

Figure 2-1. Location of Roof Vents in Vehicle

CAUTION

HydraMaster requires a powered roof vent above the air cleaner intake. Failure to install a powered roof vent in such a manner may result in serious component or engine damage.

TITAN 575

OPERATING THE TITAN 575 IN HOT WEATHER

HydraMaster recommends the following steps when operating the Titan 575 during periods of hot weather (95° F [35° C] or higher). This will help ensure that your Titan 575 continues to run at 100% capacity during even the hottest days.

1. A minimum of 9" (22.9 cm) of clearance is required on both sides of the Titan 575, when installed. Ensure that additional equipment or other materials are not stored at the sides or on top of the Titan. Unobstructed airflow around the unit is critical for cooling the engine and other components.
2. For side-door vans with "barn doors", open the doors as wide as their construction will allow. Be sure to open the doors beyond their standard "straight-out" position, if possible, by releasing the stops and putting the doors in their fully extended position.
3. Provide cross-ventilation. When possible, keeping the rear doors open while the Titan is running will substantially reduce the temperature inside the van and will provide a path for cooling air flow. For rear-mount installations, open up the other doors in the van.
4. Consider adding powered roof vents to the vehicle (if not already installed). These vents can significantly reduce interior temperatures and will result in much cooler operation. A powered roof vent is required when the Titan 575 is mounted on the optional 85 Gallon Fresh Water Tank.
5. Run the Titan 575 in HOT mode when outdoor temperatures are high. Running the Titan in WARM mode is not "easier" on the machine. In fact, it cuts the coolant heat exchanger out of the cleaning solution loop, in effect reducing the engine-cooling capacity. The Titan was designed to deliver solution at the optimum temperature to clean carpets when in the HOT mode. The WARM mode is intended for delicate materials like upholstery.

CAUTION

Use caution when drilling any holes through the van floor. Many vans have critical components mounted directly below the vehicle floor that could be damaged by a misplaced drill bit.

LOCATING THE TITAN 575 IN VEHICLE

There are two recommended entry points on the vehicle for the Titan 575 installation: the side door or the rear doors.

Most installations are through the side door. This provides rear access for accessories and hoses as well as unobstructed access to the component/working side of the machine, thus making it a bit easier to perform maintenance and/or repair without removing the unit from the truck.

Rear mounting requires the unit to be slid to the right side as far as possible. Although installing the Titan 575 through the rear door partly limits working access, it does direct the noise away from the cleaning site.

In addition, rear mounting not only provides adequate working space on the component side of the unit but also improves weight distribution inside the van (engine and component weight line up over drive shaft). Some cleaners in colder geographical areas prefer this placement for better traction in ice and snow. Also, it is physically easier to load the unit into the rear door due to the height of the vehicle bed.

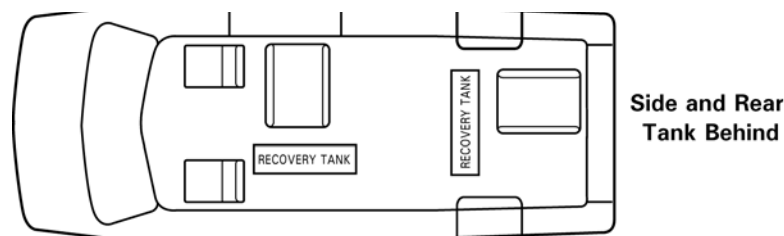

Figure 2-2. Recommended Location of Titan 575 in Van

Secure Installation

No matter how the unit is installed, check to see if the Titan 575 is properly secured to the floor of the van with the hardware provided. This safety measure will ensure that the machine will not slide inside the van. See Figure 2-2 for the correct installation.

To install the 85 gallon fresh water tank, follow the procedure outlined in the kit instructions for P/N 000-079-125.

TITAN 575

⚠ WARNING

A sudden or crash stop will cause the machine to rocket forward if not properly secured. To prevent serious personal injury, ensure that the Titan 575 is well secured to the floor of the vehicle with the hardware supplied. Protect yourself and the machine.

⚠ WARNING

HydraMaster strongly recommends that the exhaust from the front of the machine be vented down under the truck to prevent carbon monoxide from entering the job site. **Always park the truck so the exhaust is blowing away from the job site.**

⚠ WARNING

Never operate this machine with a portable gas can inside the truck. Doing so increases the risk of a fire or explosion.

⚠ WARNING

Mount a fire extinguisher just inside the rear or side door for emergencies.

⚠ WARNING

Do not use a portable propane tank inside of the truck or van. It is dangerous and illegal in most states.

⚠ WARNING

Transporting any vented fuel container that presently holds or has ever held a flammable liquid in a vehicle containing the Titan 575 is strictly forbidden by HydraMaster Corporation and by federal and state regulation.

⚠ WARNING

The engine exhaust from this product contains chemicals known to the State of California to cause cancer, birth defects or other reproductive harm.

SETTING UP THE TITAN 575

Prior to operating the Titan 575, follow these steps:

1. Adjust the vacuum relief located on the recovery tank by capping all the vacuum inlets. The machine should be set to 12" Hg maximum.

CAUTION

Setting the vacuum level higher than the recommended value can result in an increased risk of serious component damage.

The Titan 575 is shipped from the factory with antifreeze added to the solution system. Recover this antifreeze and dispose of the recovered antifreeze as stated in the local laws and regulations.

⚠ WARNING

KEEP ANTIFREEZE OUT OF REACH OF CHILDREN AND ANIMALS. Drinking antifreeze can cause death.

If required, dispose of antifreeze at facilities licensed to accept household hazardous waste. If permitted, dispose of antifreeze in sanitary sewer systems. Do not pour antifreeze into storm sewers, septic systems, or onto the ground. Doing so causes health and environmental dangers.

CAUTION

Ensure the antifreeze is completely drained from the solution system. If any antifreeze remains in the system, it could damage machine components and damage fabric.

TITAN 575

ORIENTATION OF FUEL PUMP

For proper fuel pump operation and fuel flow, the vehicle's fuel pump must be installed in a lower position with respect to the fuel tank and in as vertical a position as possible (outlet side up - see Figure 2-3 and Figure 2-4).

Mount the fuel pump away from sources of heat

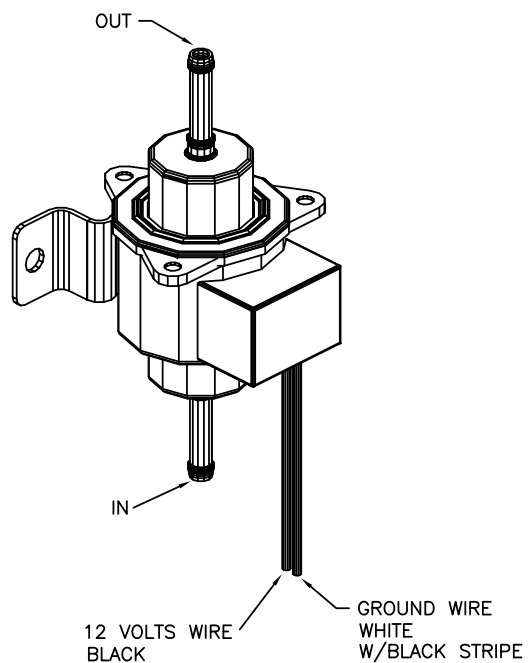

Figure 2-3. Install Fuel Pump, Outlet Side Up

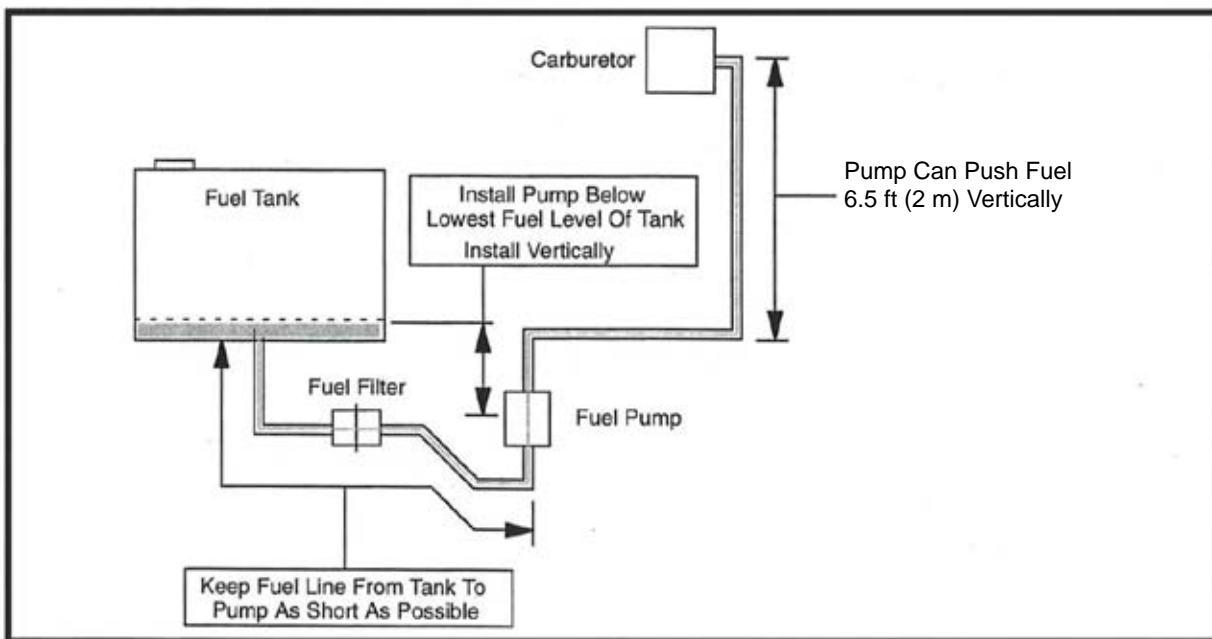

Figure 2-4. Fuel Pump Must Be in Vertical Position

3 - Cleaning Information

The Titan 575 has been engineered using the latest and most sophisticated technology available to produce the finest carpet cleaning results possible. Despite this, it remains only a tool of the carpet cleaning trade and can produce only as good a job as the person operating it.

HydraMaster strongly recommends attending an Institute of Inspection, Cleaning and Restoration Certification (IICRC) approved school as soon as possible and to always follow the IICRC guidelines when cleaning carpets or hard surfaces.

This section describes the carpet cleaning procedure in the following areas:

- Precautions
- Preparing the Carpet for Extraction
- Rinse and Recover
- Overwetting
- Streaking
- Cleaning Tool Tips
- Severe Cleaning Situations

PRECAUTIONS

The use of some chemicals (such as concentrated acids and/or solvents) in your truckmount can seriously damage the internal plumbing and high pressure pump.

CAUTION

If concentrated acids or solvents are used to pre-treat surfaces before power washing, do not recover them through the vacuum system.

HydraMaster strongly recommends purchasing a water softener system to prevent the buildup of scale and hard water deposits in your truckmount.

HydraMaster recommends only the use of chemicals containing rust and corrosion inhibitors and water softening agents to prevent chemical buildup which may lead to component failure and warranty invalidation.

Increased demand for a neutralizing rinse results in the need for special care when using these acid based chemicals in your truckmount. The negative side of these products is the corrosive effects the acid can have on metals, including fittings, pumps, heat exchangers, etc.

HydraMaster's **ClearWater Rinse™** has been formulated to protect vital components. HydraMaster will not warranty parts that have been damaged from using acid products that have obviously caused failures.

TITAN 575

PREPARING THE CARPET FOR EXTRACTION

Pre-vacuum the carpet

Whether you instruct the customer to pre-vacuum or you offer it as part of your service, proper vacuuming will make your job easier with superior end results. The more time spent removing loose particulate soil, the easier it will be to remove the oily soil stuck to the fibers.

Pre-treat the carpet

This process of applying traffic lane type chemicals to the carpet (whether by sprayer or rotary scrubber) is essential prior to extraction with your truckmount.

By applying cleaning agents to the carpet and letting them dwell 10-20 minutes prior to rinsing, you allow the product to dissolve and emulsify the oily, sticky binders holding the soil to the fiber. This will allow more soil to be removed in one or two cleaning passes and help prevent over-wetting.

Remember the solution coming out of your cleaning tool is only in contact with the carpet fiber for a few seconds. Relying on the rinse detergent to do the majority of the cleaning will result in overly long dry times and excess detergent residue left in the carpet.

HydraMaster recommends the use of our pre-sprays: **Fastbreak™** for residential carpet and **Blitz™** for commercial carpet needs.

RINSE AND RECOVER

Whether you are using a wand or an RX-20™, you should clean an area approximately 3 ft. x 3 ft. (92 cm x 92 cm) with the solution valve open then immediately go over that area with vacuum only to remove any excess moisture.

Olefin fiber is becoming more popular, particularly in commercial installations. The process mentioned above can leave excessive residual moisture because olefin fibers will not absorb any of the cleaning solution. You must only apply solution during the backward stroke of the wand so it can be immediately captured by the vacuum head. RX-20™ users should follow each pass with a dry pass. Failure to follow this procedure will cause solution to flow to the back of the carpet along with some of the soil. This, along with any soil imbedded in the backing, will be wicked to the surface of the fibers as the carpet dries.

HydraMaster recommends the following rinse aids: Alkaline - **Hydra-Dri Powder™** or **Hydra-Clean™**. Acid - **ClearWater Rinse™**.

OVERWETTING

Overwetting is an annoyance to all concerned. Extended drying times will leave the customer with a negative impression of both the cleaning company and the process used.

Several factors that will cause over-wetting include:

1. Too few vacuum strokes.
2. Clogged vacuum blower filter or vacuum tank lid not sealing properly.
3. Vacuum tank drain valve left partially open.
4. Obstructed, cut or kinked vacuum hoses.
5. Obstructed vacuum hoses while cleaning a heavily foam-saturated carpet (it is recommended to use a crystal type de-foamer distributed evenly over the carpet).

STREAKING

Streaks in the carpet can appear in both clean or dirty areas and normally appear in heavily soiled, light colored carpets.

Possible reasons of streaking may include:

1. Clogged or improperly angled spray nozzles.
2. Spray nozzles that overlap, concentrating the solution.
3. A partially clogged vacuum head.
4. Inconsistent solution temperature.

TITAN 575

CLEANING TOOL TIPS

Wands

With a wand, keep cleaning strokes short, front to back, and run a “dry pass”.

After pulling the wand for a strip of 3 or 4 ft (0.9 m or 1.2 m) long with the solution trigger activated, go back up to the top of the stroke, and make a “dry “ pass [i.e. no solution flowing]. This gives the wand a second chance to pick up the solution on the carpet.

If you do not run a dry pass, the carpet can take longer to dry, and, possibly, the pad under the carpet can become saturated.

Be aware of the carpet seams; try to use strokes that are parallel with the seam. Avoid pulling the wand across the seam. Every stroke can peel the seam connection and pull the carpet off the floor.

Also, tilt the wand handle down [head up] to move the tool forward, and away from you, on the carpet. This means less pull on the carpet and less work for you.

TITAN 575



1½" HydraHoe Carpet Cleaning Wand

Glides over carpet without chattering! 12" wide head increases production. High temperature, high pressure, stainless steel fabrication, stainless valve, quick coupler and assist handle.

Item #163-020

2" S-Bend Wand

This 12" wide wand has two jets. It uses a 1¾" tube for improved airflow and comes with an expanded 2" vacuum hose connection.

Item #163-104

1½" S-Bend Two Jet Wand

This 12" wide S-Bend wand has two jets. It uses a 1½" tube and glides over the carpet for easy operation.

Item #100-011-106

UT-14 Truckmount Stair Tool

The best stair tool on the market today. This tough stainless steel hand tool is 14" long with 6" wide cleaning head and stainless steel valve with quick coupler, assist handle.

Item #163-009

UT-40 Utility Cleaning Tool

An all purpose tool for cleaning carpeted divider panels, under restaurant booths, landings, stairs and hard to reach carpeted areas. All stainless construction, 9" wide head and 40" long shaft allows operator to "stand-up" when cleaning stairs.

Item #163-008

TITAN 575

Rotary Tool: RX-20

Rotary tools are easier to move on the carpet, but harder to control at first. With a rotary tool, remember to keep strokes short and side-to-side.

Before turning on the RX-20, adjust the handle; it should rest right below or even with the bottom of your pants' front pockets, with the tool resting flat on the floor. Take your time in adjusting the tool's height; make sure the head of the tool is flat with the floor while you are holding the handle. Relax your posture; the more difficult it is to hold the tool's head flat on the floor surface, the more quickly you will tire.

While the tool is running, control the left and right movements of the tool by tilting the head to the front and back, and lifting the handles up and pushing the handles down. The tool can be driven to the forward and backward by tilting the head of the unit to the left and right. The head must be turning to use the self driving feature of the tool, and only requires a slight bit of pressure to handles to get the head to move the tool across the floor.

As with the wand, drying times will be improved if you run a dry pass between wet passes. Hold down the solution trigger and move the unit left or right across the floor 3 or 4 ft (0.9 m or 1.2 m), then immediately back across the same pass, without the solution flowing, to make the dry pass. Make the next pass half-overlapping the previous pass.

Use the RX-20 in very heavily trafficked areas or if it has been a long time since the carpet has been cleaned. Beware of the seam edges of carpets and transition edges between floor surfaces. Use extreme caution when cleaning these areas.

Sometimes it is necessary to use an edge tool or wand to run the perimeter of the room on in difficult-to-reach areas where the circular head of the rotary units will not reach.

For Truckmount & Portable Carpet Cleaning Systems

- Aggressive Restorative Extraction Tool for Residential and Commercial Jobs
- Clean Carpet, Tile, and Grout with the RX-20 HE Total Floor Care System
- Works great on stains and heavily soiled, matted carpet.
- For truckmounts or portable carpet cleaning systems



The five vacuum heads and three spray jets rotate at 130 RPM creating 650 complete cleaning passes per minute.



Upholstery Tool: DriMaster

Use the upholstery tool on small rugs and furniture. When you clean rugs, be sure that the temperature and chemicals are safe for that particular type of rug.

As with the larger tools, do not leave the surface of the upholstery too wet. Adjust the volume of water on the tool without it touching any surface: the water should just barely come out of the tool before the vacuum pulls it back in. The water will only just spray the top layer of the furniture and the vacuum will pull the dirty water back into the tool.

If you find it necessary to do a dry pass, keep strokes short to limit the amount of water that comes into contact with the fabric surface.

DriMaster Upholstery Tool cleans faster, drier and better...all with less operator fatigue.

- Ergonomically designed
- High flow/low residual moisture - super cleaning shears away soil
- No heat loss from atomizing solution
- Never needs a dry pass
- No overwetting or overspray to clean up - solution does not reach foam backing
- Fabrics are left 50% drier than conventional upholstery tools
- Durable - virtually unbreakable
- Lightweight with comfortable handgrip
- No trigger valve for less hand strain
- Cool to the touch
- Low profile design fits in tight spots

Combine the high performance cleaning of the DriMaster Tool with optional Comfort Grip and HydraMaster's state-of-the-art cleaning chemistry, and you're ready to treat most cleanable fabrics with fantastic results!

**Grip
Part #000-061-144**



**Upholstery Tool
Part #000-163-012**

NOTICE

For more information about HydraMaster accessories, please visit this web page:
<http://hydramaster.com/Products/Accessories.aspx>.

TITAN 575

SEVERE CLEANING SITUATIONS

When your truckmount is used for hard-surface cleaning or pressure washing, some jobs may involve severe cleaning situations. In these cases, certain precautions will need to be taken in order to ensure that the recovery tank and various internal components are not damaged

The following are examples of severe cleaning situations. (This list is not intended to be complete.)

- Concrete cleaning
- Concrete stripping
- Parking lot cleaning
- Extremely greasy floors
- Cleaning that results in the recovery of extensive particulate residue
- Cleaning that results in extensive foam production

When your truckmount is used in severe cleaning situations:

- A pre-filter must be used on the vacuum hose. A fine-mesh filter (i.e. nylon) should be installed into the pre-filter. Contact your distributor for more information.
- The recovery tank should be inspected and cleaned daily.
- The recovery tank inlet filter screen should be rinsed after every job.
- The rectangular blower filter should be rinsed after every job.
- Special care should be taken to clean debris from the recovery tank float switches; they should be inspected daily to ensure that they are fully operational.
- Any cleaning job that induces excessive foam production should be halted until an approved de-foaming agent can be added to the tank.

CAUTION

Failure to follow these recommendations may lead to component failure and warranty invalidation.

CAUTION

Use of the vacuum recovery system when stripping or otherwise removing wax from floors is specifically excluded as an approved use of the truckmount. Failure to follow this exclusion may lead to component failure and will invalidate your warranty.

CAUTION

Use of the vacuum recovery system for “dry cleaning”, without corresponding solution application (i.e. duct cleaning), is specifically excluded as an approved use of the truckmount. Failure to follow this exclusion may lead to component failure and will invalidate your warranty.

CAUTION

If concentrated acids or solvents are used to pre-treat surfaces before power washing, do not recover them through the vacuum system. Failure to follow this exclusion may lead to component failure and will invalidate your warranty.

TITAN 575

4 - Operating Instructions

This section describes how to operate the Titan 575, starting with a description of the dash assembly (see Figure 4-1).

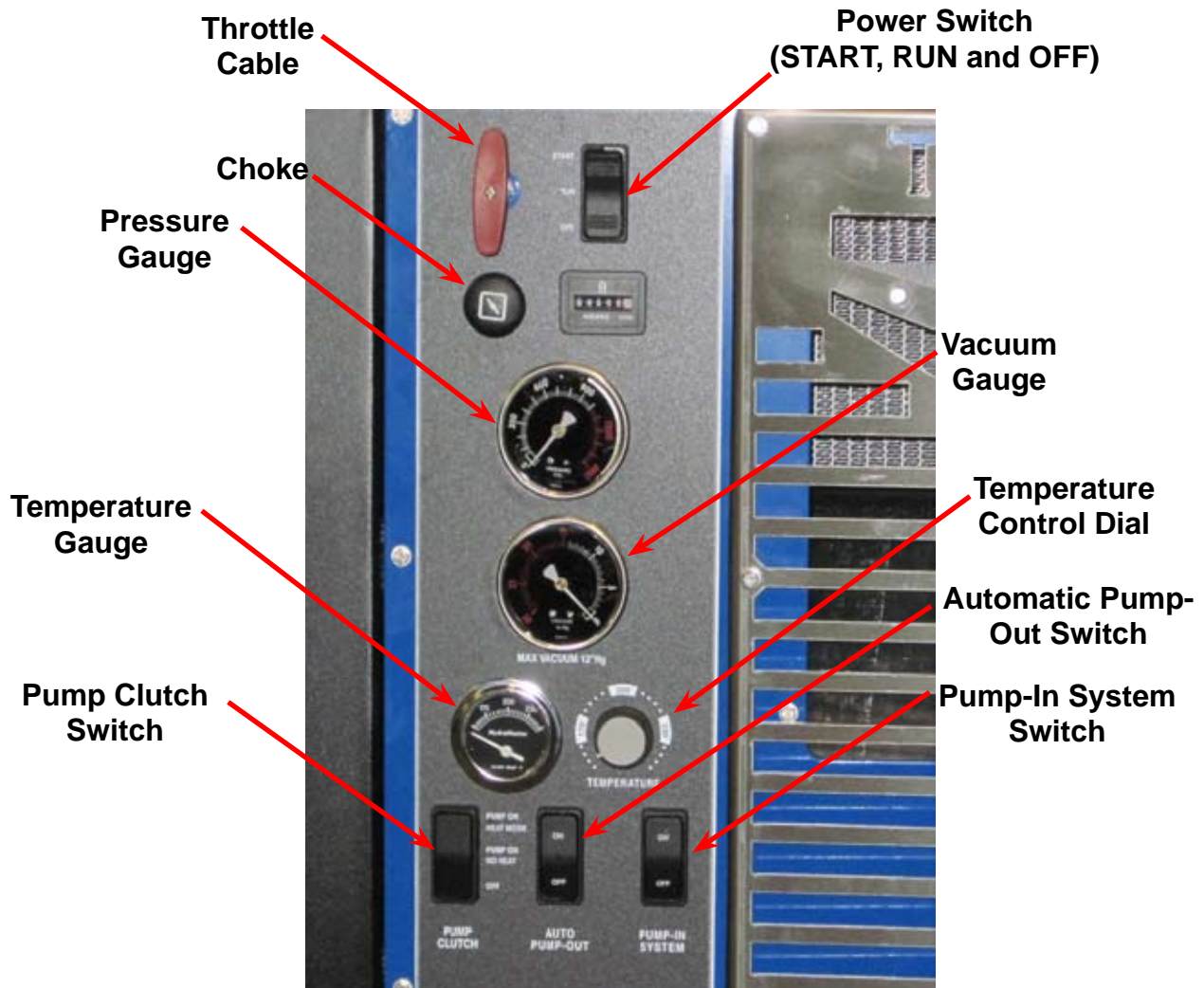

Figure 4-1. Titan 575 Upper Dash Assembly

The front dash assembly controls the:

- System's power on/off and engine speed
- Pump clutch
- Automatic Pump-Out (APO) if included in the configuration
- Pump-In system if included in the configuration

The front dash assembly also includes the solution temperature control dial; the temperature, vacuum and pressure gauges; and the hour meter.

TITAN 575

The lower dash assembly controls the:

- Water pressure
- Chemical metering
- Water box drain
- Heat selection for carpet cleaning (HOT) or upholstery cleaning (WARM) - see Figure 4-2

The lower dash assembly also houses the blower lube port and the two high pressure cleaning solution port where the wand/tools connect to the Titan 575.

Heat Selector Valve (WARM and HOT)

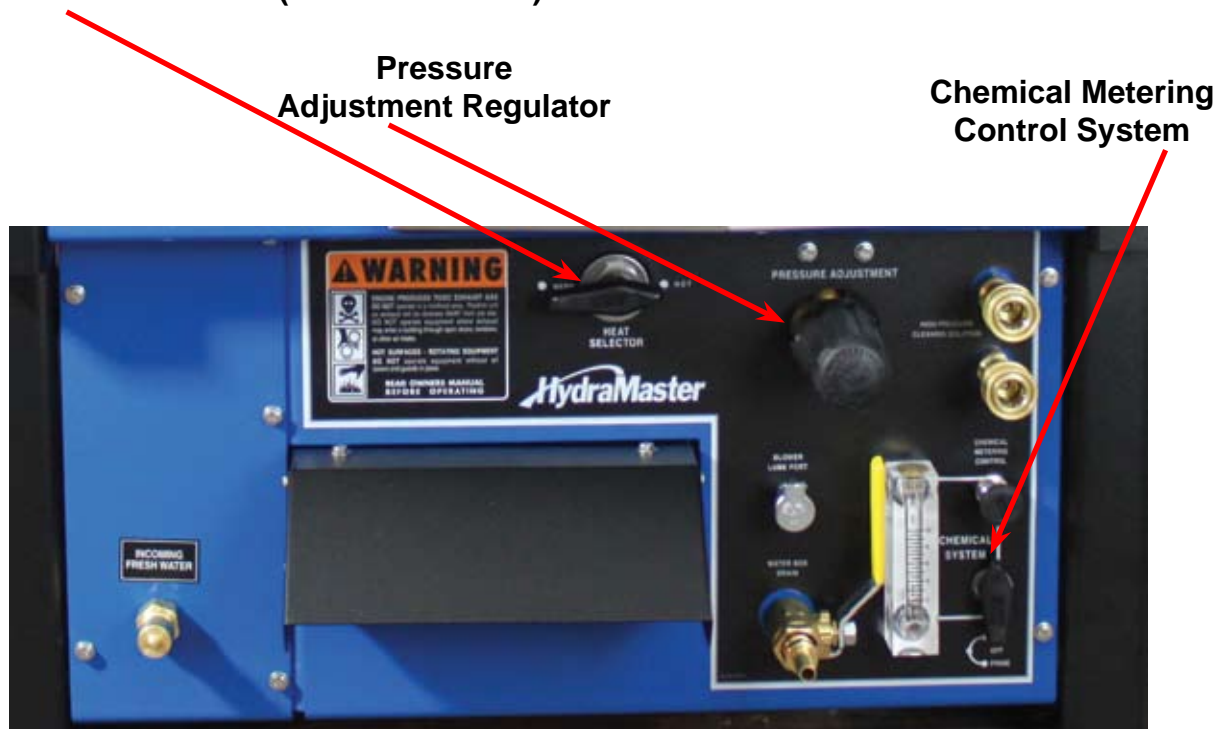

Figure 4-2. Titan 575 Lower Dash Assembly

CAUTION

To ensure proper operation of the exhaust diverter system, the Titan 575 must have a minimum of 10" Hg vacuum. If the vacuum level is lower than 10" Hg, the exhaust diverter will remain in "Divert" mode.

NOTICE

Photographs and illustrations included in this document can represent optional equipment as well as standard equipment.

TITAN 575

SETTING THE TEMPERATURE

Depending upon the type of cleaning jobs you need to do, there will be times where you will not need the maximum heat and vacuum available. There are a few different ways you can optimize the Titan 575 to the size of the job.

The different scenarios can be defined as follows:

1. Maximum – Dual wands or rotary machine usage. This means that all available power is required.
 - a. Set the Heat Selector valve to “HOT” - see Figure 4-3.
 - b. Rotate the thermostat dial to “260” - see Figure 4-4.
2. Reduced Heat – Single wand with short hose runs to the job site.
 - a. Set the Heat Selector valve to “WARM”.
 - b. Rotate the thermostat dial to desired temperature.



Figure 4-3. Heat Selector Valve



Figure 4-4. Thermostat Dial

CAUTION

Never perform cleaning operations when the truckmount engine is running at the IDLE throttle position. To do so will increase the risk of serious component or engine damage.

TITAN 575

START-UP PROCEDURE

1. Perform all daily periodic maintenance as specified in this Owner's Manual.
2. Connect a garden hose to supply water to the truckmount. If the pump-in feature is used on your system, push the "PUMP-IN" switch to the "ON" position.
3. Connect the cleaning wand or tool to the length of hose required to perform the cleaning job.
4. Start the truckmount with:
 - a. The throttle cable in the "IDLE" position.
 - b. Pull the choke cable out if the engine is cold.
 - c. The "PUMP CLUTCH" switch in the "OFF" position.
5. After the engine starts, allow the truckmount to run in "IDLE" for 2 - 3 minutes to warm up. Gradually push on the choke as the engine warms up.

CAUTION

Never clean when the Titan 575 is in the "IDLE" mode. Failure to follow this caution may result in serious component or engine damage.

6. Pull the throttle cable all the way out and lock into place.
7. Press the "PUMP CLUTCH" switch to the "PUMP ON HEAT MODE" position for carpet cleaning or upholstery cleaning; for high pressure washing, press "PUMP ON NO HEAT"
8. Set the "HEAT SELECTOR" valve to the desired position.
 - a. Set to the "WARM" position for upholstery cleaning.
 - b. Set to the "HOT" position for carpet cleaning.
9. If the Automatic Pump-Out is included in your system's configuration, press the "AUTO PUMP-OUT" switch to the "ON" position.

SETTING THE PRESSURE (FOR OPTIONAL HIGH PRESSURE WASHING KIT)

CAUTION

Lower the pressure below 1,200 psi prior to moving the “WATER PRESSURE SELECTOR” valve to “CARPET CLEANING” mode (see Figure 4-5). Failure to do so may result in serious component or engine damage.

Set the cleaning pressure to the desired level as follows.

1. Carpet Cleaning: 300 to 400 psi: Position the “WATER PRESSURE SELECTOR” valve to “CARPET CLEANING” mode (if equipped). The system is designed to shut off above 1,200 psi to protect the heat exchanger system (see Figure 4-5).
2. Hard Surface Cleaning: 1,200 psi or as indicated on tool. Position the “WATER PRESSURE SELECTOR” to “CARPET CLEANING” mode (if equipped). The system is designed to shut off above 1,200 psi to protect the heat exchanger system.
3. Pressure Washer Cleaning (if equipped): 2,000 psi or as indicated on tool. Position the “WATER PRESSURE SELECTOR” to “PRESSURE WASHING” mode (if equipped).



Figure 4-5. Location of Water Pressure Selector Valve (Labels Shown as Part of the High Pressure Washing Kit - P/N 000-079-126)

CAUTION

Do NOT apply a vacuum load while using the Titan 575 in “PRESSURE WASHING” mode. Doing so may cause the machine to overheat.

TITAN 575

4. Turn the “CHEMICAL SYSTEM” switch to the “PRIME” position to purge any air from the system (see Figure 4-6).
 - a. With the truckmount running at full throttle, block off the vacuum intake to the recovery tank. The vacuum gauge should read 12” Hg. This will assist in priming the chemical system.
 - b. Allow the chemical to flow through the chemical meter at full flow for 30 seconds.
 - c. Turn the “CHEMICAL SYSTEM” switch to “ON.” The restriction can now be removed from the vacuum inlet.
 - d. While spraying solution from the cleaning tool, adjust the chemical flow by turning the “CHEMICAL METERING CONTROL” knob.
5. Begin cleaning.



Figure 4-6. Location of Chemical System Switches

SHUT DOWN PROCEDURE

1. Flush clean water through the chemical system for 10 seconds. Turn the “CHEMICAL SELECTION VALVE” to “OFF.”
2. Cool the truckmount down by turning the “PUMP CLUTCH” switch to “PUMP ON - NO HEAT”. Spray the cleaning wand into the vacuum hose for 3-5 minutes. The chemical should now be flushed from the truckmount, hoses and cleaning tool.
3. Remove the vacuum hose.
4. Lubricate the blower to prevent it from rusting internally.
 - a. Allow the unit to run for a few minutes with the vacuum hose disconnected in order to remove moisture from the blower.
 - b. Cap off the inlet(s) to the vacuum tank.
 - c. Spray a HydraMaster-recommended spray lubricant into the “BLOWER LUBE PORT” for about 5 to 10 seconds while the unit is running (see Figure 4-7).
 - d. Allow machine to run additional 2 to 5 minutes under load to flush off lubricant.
 - e. Uncap the inlet(s) and run the unit for another minute to allow the blower to cool down.



Figure 4-7. Location of Blower Lube Port on Lower Dash Assembly

5. If freeze guarding is necessary, perform the procedure at this time. See the Freeze Guarding section of this Owner’s Manual (see page 5-19).
6. Push the throttle cable to the “IDLE” position.
7. Turn the ignition switch to “OFF.”
8. Drain the water box using the valve.
9. Drain the vacuum tank in an appropriate location.

TITAN 575

NOTICE

In accordance with EPA, state and local laws, do not dispose of water into gutters, storm drains, streams, or reservoirs.

10. Perform daily maintenance as specified in Section 5 of this Owner's Manual.

5 - Machine Maintenance

To avoid costly repairs and downtime, it is imperative to develop and practice good maintenance procedures. These procedures fall into daily, weekly, monthly and quarterly increments and are outlined below. All maintenance must be performed by qualified service personnel.

A maintenance log, provided in the Owner's Guide, must be correctly and completely filled out. HydraMaster may request to inspect the logs before a warranty claim is honored. It is recommended that the log be affixed to the vehicle door near the truckmount for convenience and to serve as a maintenance reminder.

This section describes how to properly maintain the truckmount in the following areas:

- Operational Maintenance
- Overall Machine Maintenance
- High Pressure Pump Maintenance
- Vacuum System Maintenance
- Descaling Procedure (Required)
- Freeze Guarding

TITAN 575

OPERATIONAL MAINTENANCE

Daily Maintenance

- Check the engine oil level. Add oil if needed.
- Check the high pressure pump oil. Add oil if needed.
- Check the oil level in the blower. Add oil if needed.
- Check coolant overflow bottle level. Add coolant if needed.
- Inspect and clean the recovery tank filters.
- Inspect and clean the garden hose screen.
- Inspect the truckmount for water and oil leaks, loose electrical connections, etc. and repair as needed.
- Lubricate the blower with a HydraMaster-recommended lubricant.

Weekly Maintenance

- Inspect the recovery tank filters for tears, holes, etc. Repair or replace as needed.
- Inspect the vacuum relief valve. Clean and lubricate as necessary.
- Clean the recovery tank thoroughly with pressure washer.
- Check the pump belt, blower belt drive, and fan belt for wear and proper tension. Adjust as needed.
- Check all the hoses and wiring for wear and chafing. Secure as needed.
- Flush the water and chemical systems with solution of equal parts white vinegar and water.
- Check all the nuts and bolts. Tighten as needed.
- One time change of the high pressure pump oil after 50 hours of operation. (Every 500 hours thereafter.)
- One time change of the engine oil and oil filter after 25 hours of operation.
- Change the engine oil every 100 hours. (Every 50 hours if operating in high ambient temperatures.) Change oil filter every oil change.

Monthly Maintenance

- Check the engine air filter. Clean or replace as necessary.
- Check the water level in battery. Fill as needed.
- Clean the battery terminals as needed.

Quarterly Maintenance

- Check the fuel lines. Repair or replace as needed.
- Clean and gap the spark plugs to 0.028" (0.7 mm). Replace if excessive carbon buildup is visible.
- Change the blower oil after first 100 hours of use.
- Check fuel filter. Replace as necessary.

500 Hours

- Change the blower oil.
- Change the high pressure pump oil.
- Replace spark plugs.
- Change fuel filter.
- Change coolant.

1,000 Hours

- Replace spark plugs.
- Change air filter.
- Flush coolant system.
- Check the engine valve clearance (intake and exhaust 0.006" to 0.0075" [0.1524 mm to 0.1905 mm]).
- Check plug wires. Replace as necessary.
- Check carburetor. Clean or replace as necessary.

NOTICE

Refer to the Interval in Hours Maintenance chart in the Owner's Guide for more information.

TITAN 575

OVERALL MACHINE MAINTENANCE

Maintenance, troubleshooting and repair are much easier tasks to accomplish on a clean truckmount. Regular cleaning of the truckmount offers the user an opportunity to visually inspect all facets of the truckmount and spot potential problems before they occur. In addition to the operational maintenance the following “housekeeping” duties should be performed.

After each job

- Check the recovery tank and the recovery tank filters. Empty and clean as necessary.

Daily

- Wipe the truckmount down thoroughly with a damp cloth.
- Wipe down the vacuum and high pressure hoses as needed.
- Inspect and clean the vacuum slot on the cleaning wand.
- Check the wand head for sharp edges that could tear carpet. File down as needed.
- Clean the wand to maintain original appearance.
- Visually inspect the hoses for abrasions, cuts, etc. Repair or replace as needed.

Weekly

- Empty the chemical container. Wash out thoroughly to remove any chemical buildup.
- Inspect the chemical feed line strainer and use solution of equal parts white vinegar and water to remove any chemical buildup.
- Thoroughly clean the wand and inspect for clogged jets, debris in vacuum slot and leaking fittings at valve.
- Thoroughly clean the vacuum and high pressure hoses including quick releases and cuffs.

ENGINE MAINTENANCE

Engine Oil Level Check

The engine oil level should be checked daily. It is recommended that the oil be checked just before the engine is started for the first time for that day. The oil level should be between the 'Add' and the 'Full' marks on the dipstick.

CAUTION

Do not operate the engine with the oil level below the bottom of the 'Add' mark on the dipstick, or above the top of the 'Full' mark.

Adding Engine Oil

It is normal to add some oil in the period of time between oil changes. The amount will vary with the severity of operation. When adding or replacing engine oil, be sure the oil meets or exceeds the recommended specification.

Changing Engine Oil and Filter

The engine oil and filter must be changed every 100 hours or every 3 months whichever occurs first. The oil and filter should be changed more often if the engine is operating in dusty or extremely dirty areas, or during cold weather.

Engine Oil Quality

To achieve proper engine performance and durability, it is important that you use only engine lubricating oils of the correct quality in your engine. Proper quality oils also provide maximum efficiency for crankcase ventilation systems, which reduces pollution.

CAUTION

Use only engine oils displaying the American Petroleum Institute (API) "starburst" certification mark 'FOR GASOLINE ENGINES' on the container.

Engine Oil Recommendation

While multi-viscosity oils are generally recommended, SAE 5W-30 synthetic is specifically recommended year round for your Titan 575 engine.

TITAN 575

Oil Filter

Kubota engines use Kubota oil filters. An equivalent or better oil filter must be used when servicing the engine.

To replace the filter, use a proper filter wrench to remove the filter.

Clean the filter mounting base and lightly coat the gasket surface of the new filter with engine oil. Hand tighten the filter until the gasket contacts the base, then tighten another ½ turn. Fill the engine with the correct amount of oil, run the engine and check for oil leaks at the drain plug and oil filter gasket.

Spark Plugs

Always use the recommended spark plugs for your engine. Hotter or colder plugs, or similar plugs that are not exact equivalents to the recommended plugs, can cause permanent engine damage, reduce the engines useful life, and cause many other problems such as hard starting, spark knock and run-on. Installing new spark plugs regularly is one of the best ways to keep your engine at peak performance.

Cooling System

Coolant Level

Check the coolant level in the coolant overflow reservoir daily. Generally a good time to do this is just prior to starting the engine for the first time each day.

Maintain the coolant level in the radiator at ¾ " (19 mm) below the filler neck seat of the radiator when the coolant is cold. When the coolant level is checked, inspect the condition of the radiator caps rubber seal. Make sure it is clean and free of any dirt particles which would keep it from seating on the filler neck seat. Rinse off with clean water if necessary. Also make sure that the filler neck seat is free of any dirt particles.

▲ WARNING

Never remove the radiator cap under any condition while the engine is operating. Failure to follow these instructions could result in damage to the cooling system, engine, or cause personal injury. DO NOT add coolant to any engine that has overheated until the engine cools.

The engine manufacture requires the cooling system to be filled with a 50/50 mixture of glycol-based antifreeze. Distilled water is recommended in hard water areas.

CAUTION

Always maintain a 50% solution of phosphate-free/low-silicate antifreeze at all times for adequate heat dissipation, lubrication and protection from freezing. Major brands are typically low phosphate or phosphate free, and will be labeled accordingly on the container. It is recommended that you consult the technical data sheet for the brand of coolant you are using to determine if it meets the low phosphate requirement. Failure to use a 50% solution of phosphate-free/low-silicate antifreeze may result in corrosion of the cooling system.

Bleeding Air from Cooling System

It is necessary to remove all of the air from the engine to prevent overheating. If the coolant has been drained for any reason, it will be necessary to follow the bleed procedure.

When the engine is cold, remove the radiator cap. Fill the radiator until it is to the top of the filler neck. Start the engine and run in the low rpm position, pump clutch off, and no vacuum load. Allow the engine coolant to heat up and open the thermostat several times. As all the air is removed from the system, the level of the radiator should lower below the internal tubes. This process should take approximately 5 - 10 minutes. Top off the coolant and install the cap. In the event you experience a coolant shutdown due to overheat, allow the machine to cool down and repeat this procedure.

Radiator

Inspect the exterior of the radiator for obstructions. Remove all debris with a soft brush or cloth. Use care to avoid damaging the core fins.

Fuel Filter

The fuel filter is located between the fuel pump and the fuel tank underneath the vehicle.

TITAN 575

HIGH PRESSURE PUMP MAINTENANCE

Daily

Check the oil level and the condition of the oil. The oil level should be up to the center of the sight glass on the side or rear of the pump or between the “MIN” and “MAX” lines on the dipstick. The dipstick may be found by removing the oil cap.

Periodically

Change the oil after the initial 50 hours of operation and every 500 hours after that. It may be necessary to replace the pump seals and check valves at 500 hours if the truckmount has been running in high ambient temperatures.

Refer to the Pump Servicing Section in the following page for more information.

CAUTION

If the oil becomes discolored or contaminated one of the oil seals may be damaged. Do not operate the pump if the crankcase oil has become contaminated. Do not rotate the drive shaft without oil in the crankcase reservoir.

The pump should never be run dry. Running the pump dry will cause premature wear on the seals, packing and plungers. Running the pump dry for a prolonged period of time may cause damage that cannot be repaired and voids warranty.

Do not run the pump with frozen water in the manifold. If there is a risk of freezing, freeze guard the truckmount. See the Freeze Guarding section on page 5-19 of this manual.

Servicing Valves on the High Pressure Pump

Removing a Valve

1. Remove the valve cap (30 mm) and extract the valve assembly (see Figure 5-1).

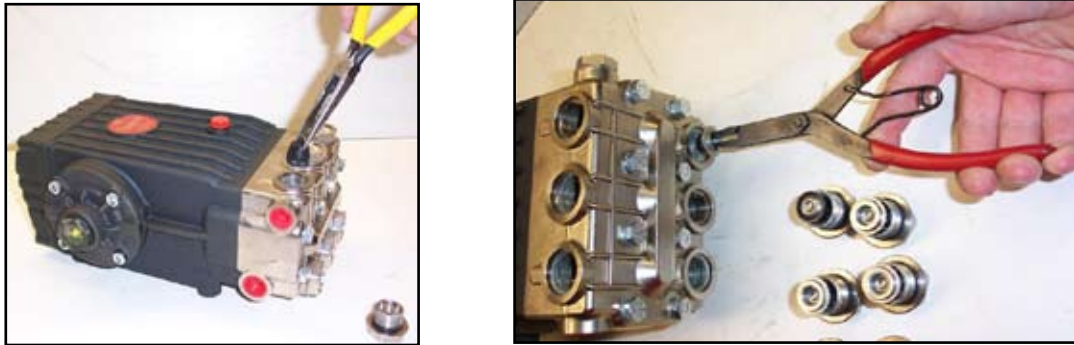

Figure 5-1. Remove Valve Cap and Valve Assembly

2. Remove the valve assembly (retainer, spring, valve plate, valve seat) from the valve cavity.
3. Remove the O-ring and support from the valve cavity.
4. Examine the O-ring and replace if there is any evidence of cuts, abrasion, or distortion.
5. Inspect the manifold for wear or damage (see Figure 5-2).
6. Inspect the old valves for wear or damage. Only one valve kit (P/N 000-078-519) is necessary to repair all the valves in the pump. (The kit includes new supports, O-rings, valve seat, valve poppet, spring and retainer; all are pre-assembled.)



Figure 5-2. Inspect Manifold and Old Valves

TITAN 575

7. Replace the center inlet check valve with a modified check valve (P/N 000-169-212 - Figure 5-3).

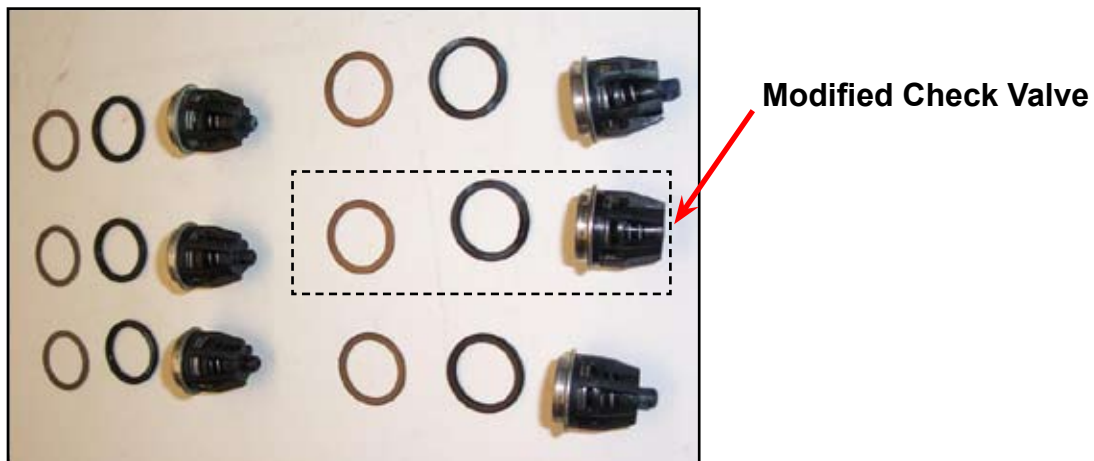

Figure 5-3. Replace Center Inlet Check Valve With Modified Check Valve

8. Apply O-ring grease to O-rings and install valves (Figure 5-4).
9. Replace valve cap and torque to 95 ft. lbs.(13 m kgs) see Figure 5-5).



Figure 5-4. Apply Grease and Install Valves



Figure 5-5. Replace Valve Cap and Torque to 95 ft. lbs. (13 m kgs)

10. Remove the fasteners retaining the manifold
11. Separate manifold from crankcase (see Figure 5-6).



Figure 5-6. Separate Manifold from Crankcase

NOTICE

It may be necessary to rotate crankshaft or tap manifold with rawhide or plastic mallet to loosen.

CAUTION

When sliding manifold from crankcase, use caution not to damage ceramic plungers.

12. The seal assemblies may come off with the manifold (see Figure 5-7)

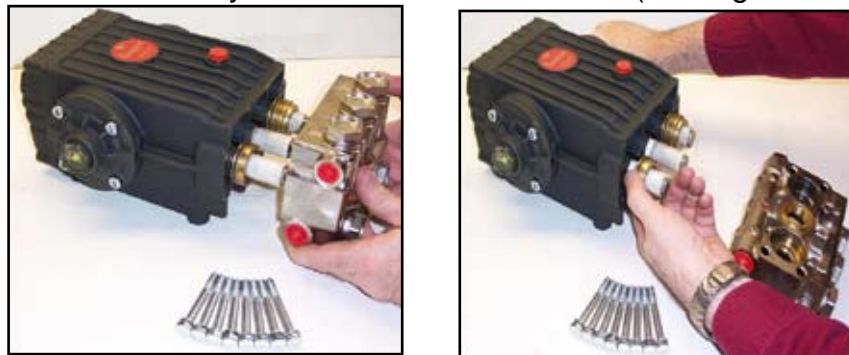

Figure 5-7. Seal Assemblies May Come Off with Manifold

13. Examine the ceramic plungers. The surface should be smooth and free from scoring, pitting or cracks (see Figure 5-8); if not, replace.
14. Loosen the stainless steel plunger bolt.



Figure 5-8. Examine Ceramic Plungers

TITAN 575

15. Remove the stainless steel plunger bolt and ceramic plunger from the plunger guide (see Figure 5-9).
16. If the slinger washer is removed, be certain it is re-installed or replaced.
17. Separate plunger bolt from ceramic plunger (see Figure 5-9).

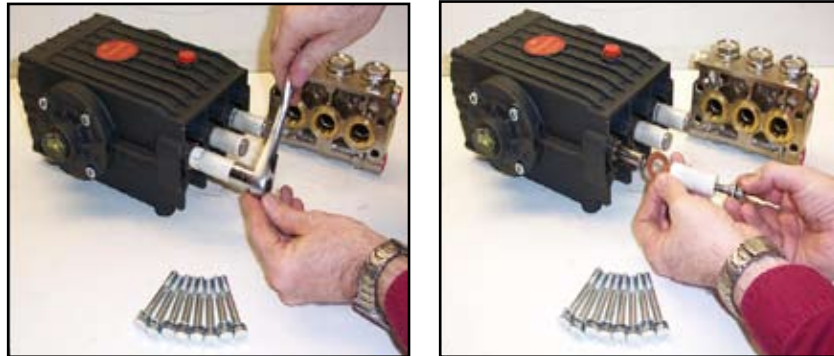

Figure 5-9. Remove Stainless Steel Plunger Bolt and Ceramic Plunger

18. Install new Teflon® back-up ring and O-ring on the plunger bolt. Apply a film of O-ring grease on the outside of the O-ring (see Figure 5-10).
19. Apply removable anaerobic thread sealant (Loctite® 542) to the threads of the plunger bolt, carefully pressing the plunger bolt into ceramic plunger (see Figure 5-10).
20. Slide new ceramic plunger over the plunger guide (see Figure 5-10).

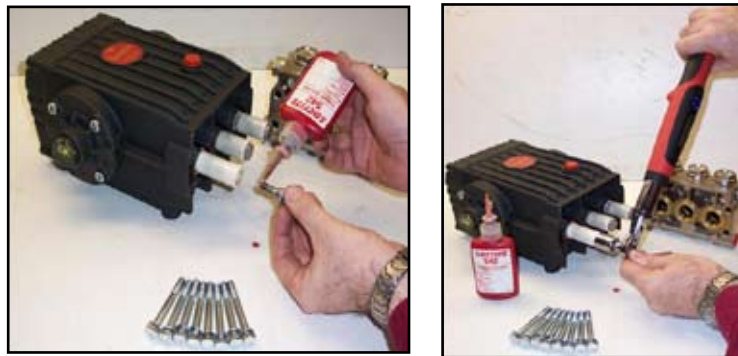

Figure 5-10. Install O-ring, Apply Sealant and Slide Plunger over Plunger Guide

21. Torque plunger to 14.5 ft. lbs (2 m kgs).

Extracting Seals

With manifold removed from crankcase:

1. Insert proper extractor collet through main seal retainer (see Figure 5-11).
2. Tighten collet and extract retainers and seals.

NOTICE

The Teflon seals of the HT series will be damaged during disassembly so new ones will have to be installed.

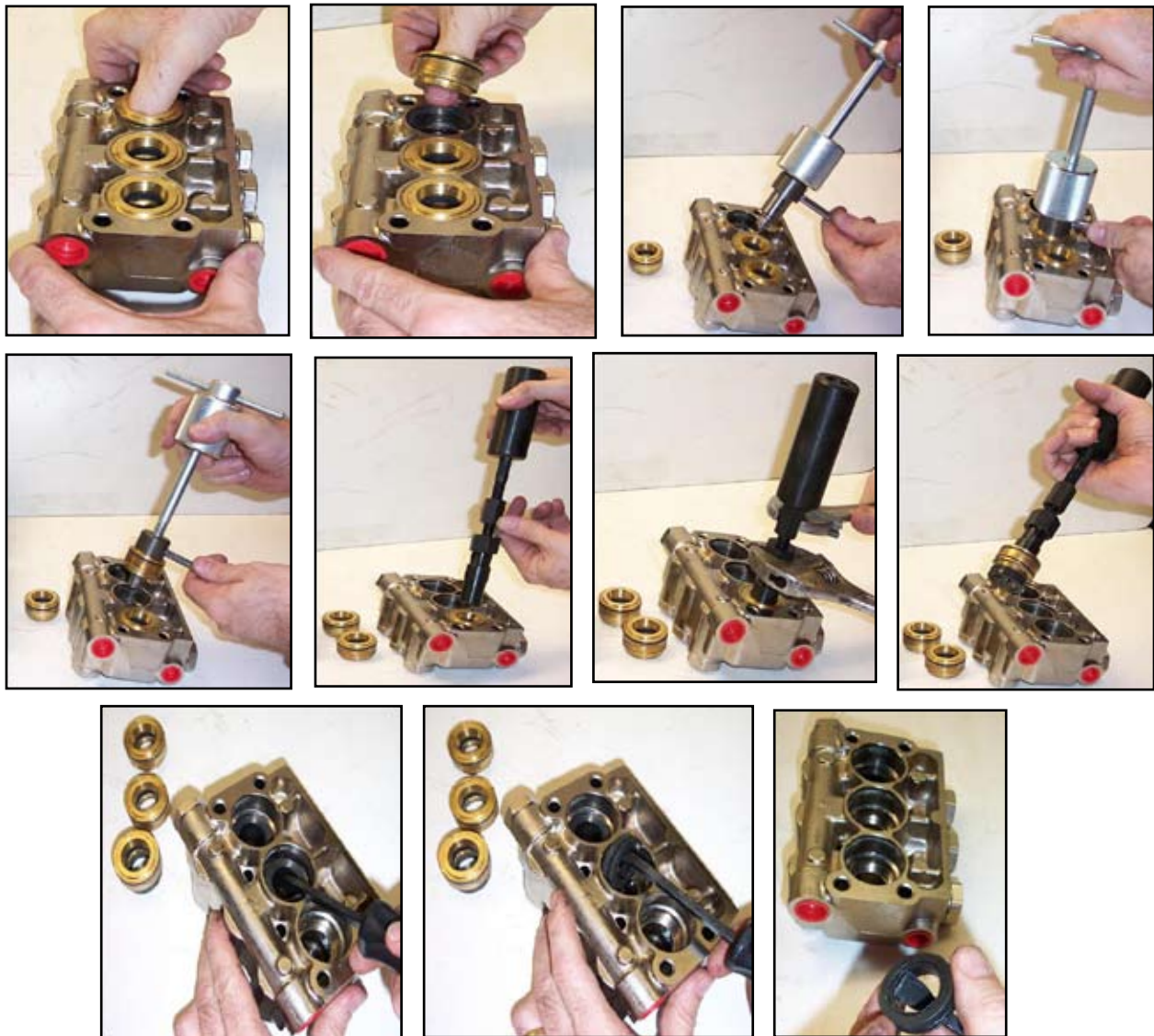

Figure 5-11. Extract Retainers and Seals

TITAN 575

Replacing the Seal Assemblies

Only one seal kit (P/N 078-518) is necessary to repair all the seals in the pump (see Figure 5-12). Use an insertion tool for seal installation



Figure 5-12. Seal Kit and Insertion Tool for Seal Installation

To install a seal assembly:

1. Apply a film of O-ring grease on the O-ring on the outside of the new high pressure seal.
2. Insert the high pressure seal into the cavity with the “U” shape down.
3. Press high pressure seal into place.
4. Apply a film of grease on the O-ring on the brass retainer (see Figure 5-13).

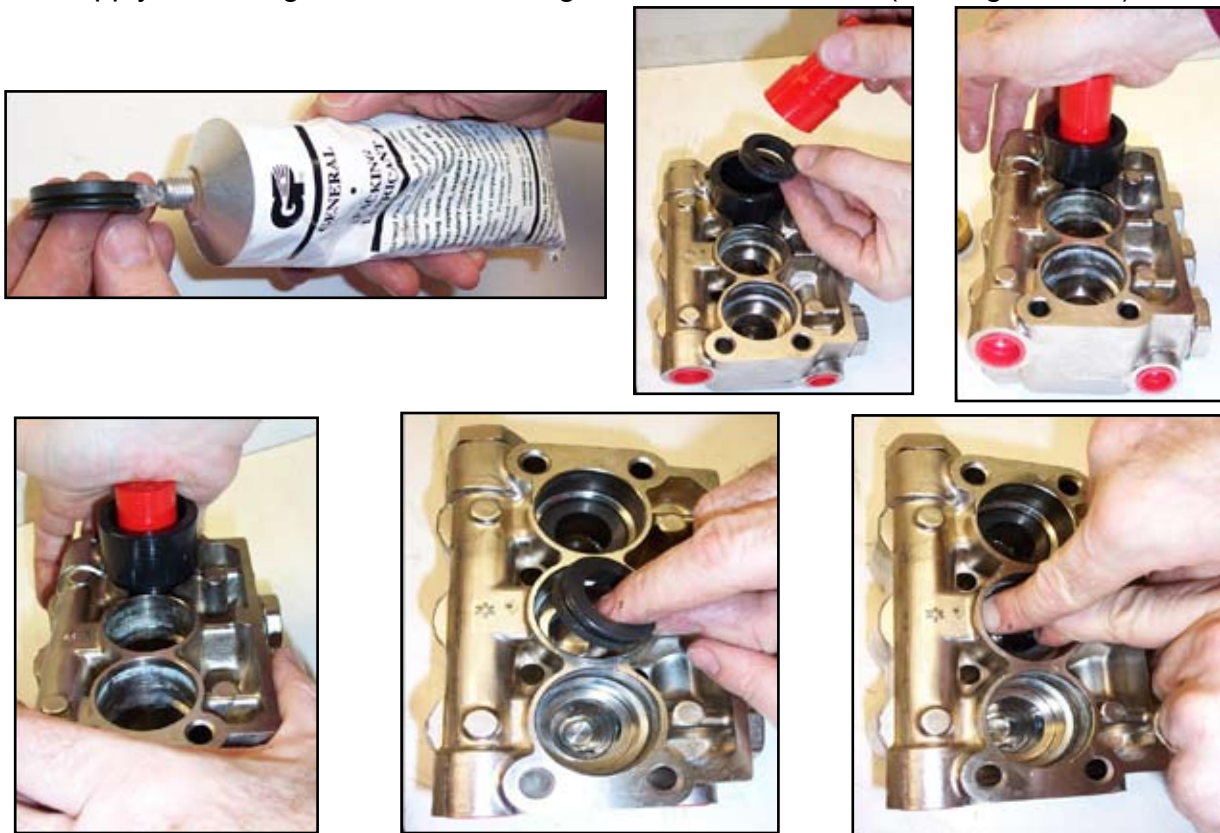

Figure 5-13. Install Seal Assembly Using O-Ring Grease

To install the intermediate retainers and the low pressure seals:

1. Insert the brass intermediate retainer into the cavity.
2. Press the new low pressure seal into the brass low pressure seal retainer and install a new O-ring on the outside (see Figure 5-14).

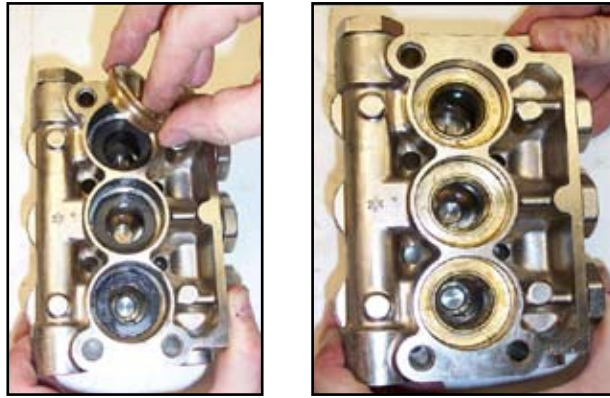

Figure 5-14. Install Retainers into Cavities

3. Press the low pressure seal assembly into the cavity (see Figure 5-15).

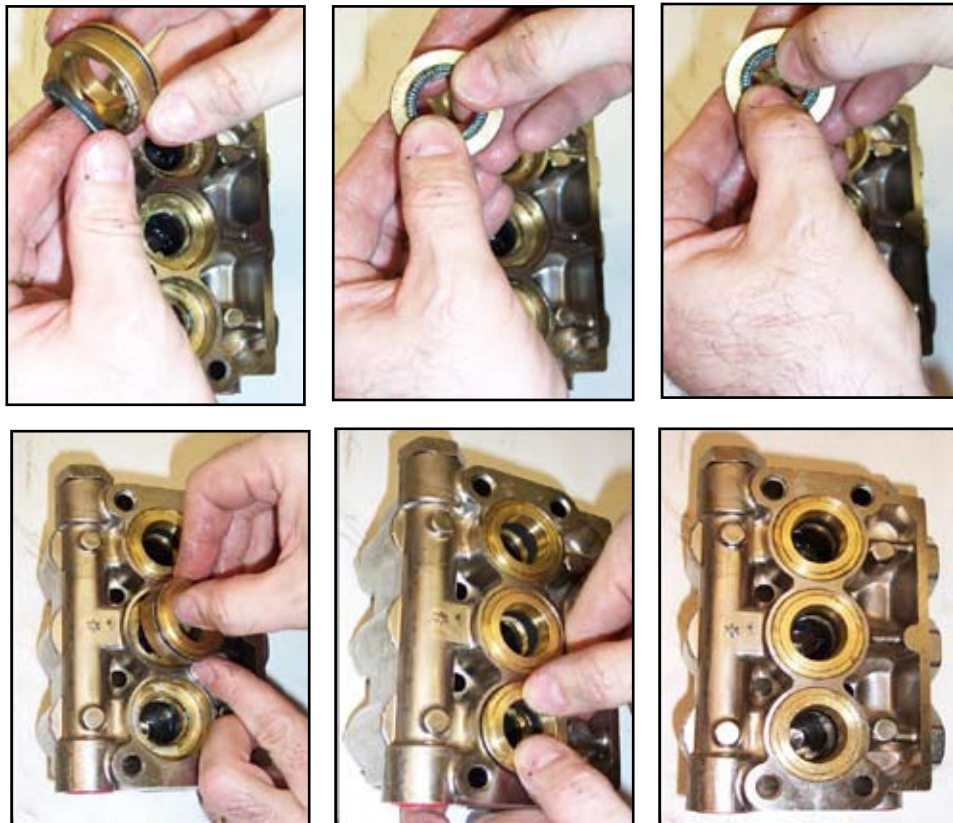

Figure 5-15. Press Low Pressure Seal Assembly into Cavity

TITAN 575

Re-Installing Manifold

1. Position the outer plungers at the same position (see Figure 5-16).
2. Re-install manifold and torque the fasteners in an "X" pattern to 50% of specification and then retorque to 100% specification (see Figure 5-17 and Figure 5-18).



Figure 5-16. Re-install Manifold and Torque Fasteners

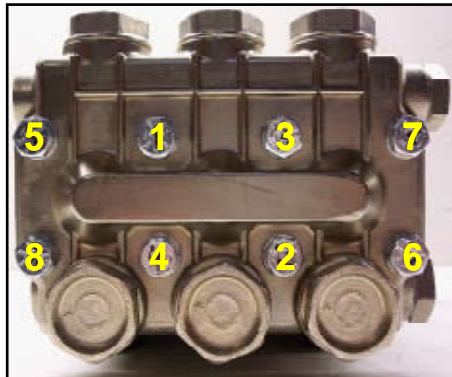
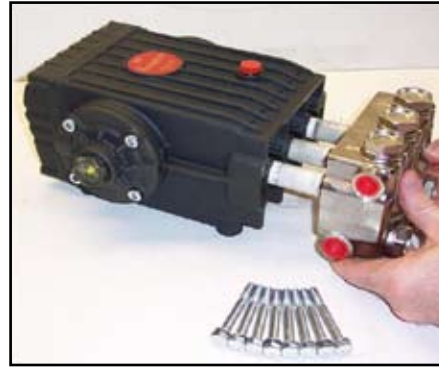

Figure 5-17. Torque Sequence in "X" Pattern

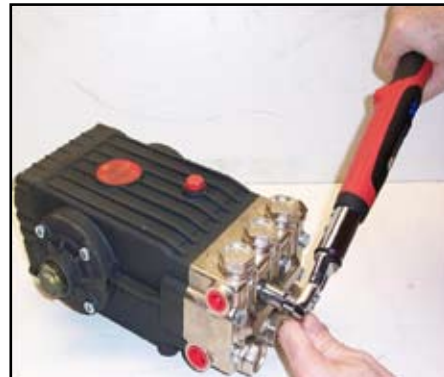

Figure 5-18. Torque Bolts to 22 ft. lbs (3 m kgs)

VACUUM SYSTEM MAINTENANCE

The vacuum pump in this machine is commonly referred to as a “rotary positive displacement blower” or “blower” for short. The performance and life of the truckmount is greatly dependent on the care and proper maintenance it receives. The manual for the blower has been included. Review the manual for a better understanding of this piece of machinery.

CAUTION

To protect the blower from overloading and damaging itself, there is a vacuum relief system installed on the vacuum tank. When the vacuum tank inlet is completely sealed off a maximum of 12” Hg will be attained.

CAUTION

Solid objects entering the blower will cause serious damage to the internal components of the blower. Extreme caution should be used when the truckmount is being run for test purposes with the inlet to the blower open to the atmosphere.

CAUTION

Foam passing through the blower can lead to serious problems with the truckmount. It is important to keep the vacuum tank free of foam. The tank is protected from overflowing by a float kill switch; however, this switch is not activated by foam.

Daily

At the end of each day the internal components of the blower need to be lubricated. This helps to prevent rust deposits and prolongs the life of the truckmount.

To lubricate the blower:

1. Allow the unit to run for a few minutes with the vacuum hose disconnected in order to remove moisture from the blower.
2. Cap off the inlet(s) to the vacuum tank.
3. Spray a HydraMaster-recommended spray lubricant into the “BLOWER LUBE PORT” for about 5 to 10 seconds while the unit is running.
4. Uncap the inlet(s) and run the unit for another minute to allow the blower to cool down.

Periodically

Change the oil in both ends of the blower after the initial 100 hours of use. The oil is to be changed each 500 hours of use thereafter.

TITAN 575

DESCALING PROCEDURE (REQUIRED)

Scale deposits on the interior of the heating system can cause a noticeable loss in heating performance. Deposits of this kind result from hard water. The frequency with which descaling procedures are required will vary. If the area has particularly hard water, you may have to descale often.

To descale the system, add an appropriate descaler chemical to the water box. Circulate it through the system. Let it stand. Flush and repeat as necessary. Clean all screens and strainers, and check them frequently following descaling.

NOTICE

If using TM DeScaler™ through the flow meter, make sure to run clean water through the flow meter after this procedure.

To descale using the recirculation kit (P/N 000-078-058), start with an empty water box. Fill a third of the water box with TM DeScaler™. Follow the recommendations on the TM DeScaler™ label for proportions. Verify that the float is not lying horizontal, but floats below.

Attach the recirculation fitting provided in the kit to the garden hose quick connect (see Figure 5-19) and this combination to the front of the truckmount.

Attach one section of the solution hose to the outgoing solution fitting on the front of the truckmount and the other end to the garden hose and recirculation fitting combination that is attached to the front of the truckmount. Additional hoses may be attached inline if descaling of hoses is needed.

Start the truckmount and allow it to run for 3 to 5 minutes. Do not leave the TM DeScaler™ solution in the system. Flush the system with clean water and turn the truckmount "OFF."

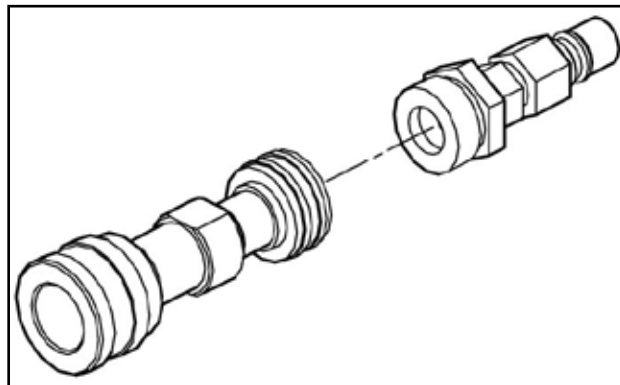

Figure 5-19. Recirculation Fitting

FREEZE GUARDING

To avoid permanent damage to the truckmount, it is imperative to follow the Freeze Guard Procedure whenever the possibility of freezing temperatures exists.

CAUTION

When disposing of antifreeze, follow local laws and regulations. Do not discard into storm sewers, septic systems or onto the ground.

⚠ WARNING

Antifreeze is harmful or fatal if swallowed. Do not store in open or unlabeled containers. Keep out of reach of children and animals.

Freeze Guard Procedure

1. With the truckmount turned off and the incoming water line disconnected, open the water box drain valve on the front of the truckmount. Allow the system to fully drain. Close the water box drain valve.
2. Add 2 gallons (7.57 litres) of 50/50 antifreeze and water mix to the water box.
3. Attach a recirculation fitting (See the previous page and Figure 5-19) to the incoming water quick connect on the front of the machine.
4. Attach a section of solution hose to the outgoing solution fitting on the front of the machine. Attach the opposite end to the recirculation fitting. (If more sections of hose are to be freeze guarded, attach those inline.)
5. Start the truckmount and allow it to run for 2 to 3 minutes. Turn the HEAT SELECTOR VALVE to "HOT" for 1 minute and then to "WARM" for 1 minute. This will distribute antifreeze solution throughout the truckmount.
6. Remove the chemical feed line from the chemical jug. Turn the SELECTOR VALVE to "PRIME." This will vacuum the chemical remaining in the lines to the recovery tank.
7. Remove the recirculation fitting from the truckmount.
8. Spray the antifreeze and water mix out of the truckmount and into a container to reclaim the solution. Run the solution until it stops.
9. The truckmount is now freeze guarded. Remember to flush antifreeze from the system prior to carpet cleaning. See the following procedure.

NOTICE

The reclaimed antifreeze solution may be used three times before being discarded.

TITAN 575

NOTICE

To freeze guard the hoses and wand, perform the preceding procedure with the items to be freeze guarded attached.

CAUTION

Always check the freezing level of your reclaimed antifreeze with a glycol tester before reusing. Failure to do so may result in serious component damage.

Recovering Antifreeze for Re-Use

1. Attach all hoses and wands which have been freeze guarded to the truckmount.
2. Attach the incoming water source to the front of the truckmount.
3. Start the truckmount.
4. Spray the solution through the hoses and wands into a sealable container until all signs of antifreeze are gone.

Freeze Protection of the Pump-In System

1. Drain the fresh water tank.
2. Remove the garden hose adapter from the pump-in pump hose and position the hose so it is pointing outside the van.
3. Turn on the pump-in pump and run for 1 - 2 minutes until all the water is purged from the hose.

NOTICE

The next time the truckmount is used, it may take a few minutes before the water box begins to fill.

6 - Water and Chemical System

This section describes the Titan 575's water and chemical systems, and includes the exhaust subsystem.

Parts of the text are also included in the section's annotated illustrations which are referenced in the following paragraphs (see Figure 6-1 – Figure 6-6).

1. The process starts when fresh water is brought through the front of the truckmount into the water box, as indicated in Figure 6-1. The level of water in the box is maintained by the use of a float valve. The water is then gravity-fed to the pump where it is pressurized.
2. Next, the pressurized water enters the bypass valve. This valve allows manual adjustment of the pressure level. When the valve at the wand is closed, all the water in the system is recirculated to the water box. When solution is being used at the wand, the necessary amount of high pressure water passes through the bypass valve and to the heat exchanger (see Figure 6-1).
3. In the tube and shell heat exchanger, the temperature is raised. The heat necessary to do this is provided by the engine coolant. Heated water then travels to the blower heat exchanger. In this heat exchanger, the temperature of the water is raised once again. The heat necessary to do this is provided by both the engine and blower exhausts (see Figure 6-6). The heated water finally travels to the high pressure manifold (see Figure 6-1).

NOTICE

The high pressure manifold houses both the temperature sensor for the temperature gauge and the high temperature shutdown switch. This innovative, revolutionary system does not require a recirculation orifice or filter to maintain temperature within the heating system.

When water is not flowing through the cleaning tool, the water within the heat exchange system stops circulating completely.

TITAN 575

Water temperature is controlled via a temperature sensor inside the heat exchanger. When the system achieves the maximum operating temperature, the diverter valve will “divert” all heat away from the heat exchanger which allows the system to control its internal temperature without dumping water.

This saves valuable space in the recovery tank, which can be used instead for recovery of dirty water from the cleaning surface.

4. Water that is recirculated through the pressure regulator back to the water box travels past a thermostatic valve. This thermostatic valve monitors the water box temperature. When the controller senses the water in the water box has reached its set point, it opens the low pressure thermostatic valve on the side of the water box and closes once the temperature drops back below the set point (see Figure 6-2).
5. The water that is being called for by the wand then exits the manifold and passes through a check valve (see Figure 6-2).
6. Finally, the water joins the chemical where the solution is created (see Figure 6-2)
7. The chemical is pressurized by the HydraMaster diaphragm chemical pump attached to the head of the water pump. This pump pulls the chemical from the chemical, or soap, jug through the chemical flow meter (see Figure 6-3).
8. After being pressurized, the chemical travels through the metering valve and is injected into the high pressure stream. This solution then exits the front of the truckmount and is delivered to the cleaning tool (see Figure 6-3).

Figure 6-1. Annotated Water, Chemical and Solution Flow Diagram - View 1 of 3
7459

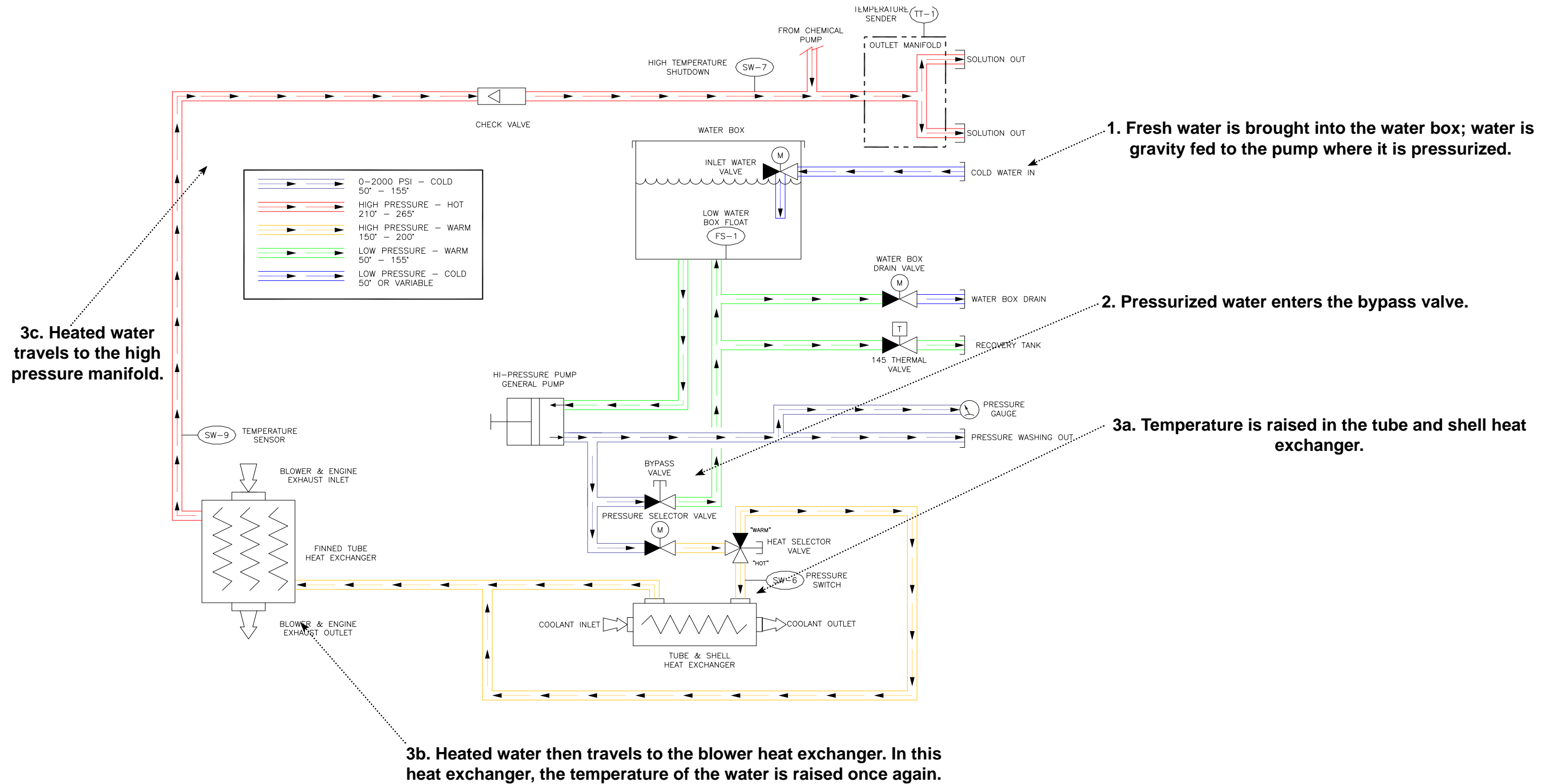

TITAN 575

Figure 6-2. Annotated Water, Chemical and Solution Flow Diagram - View 2 of 3
7459

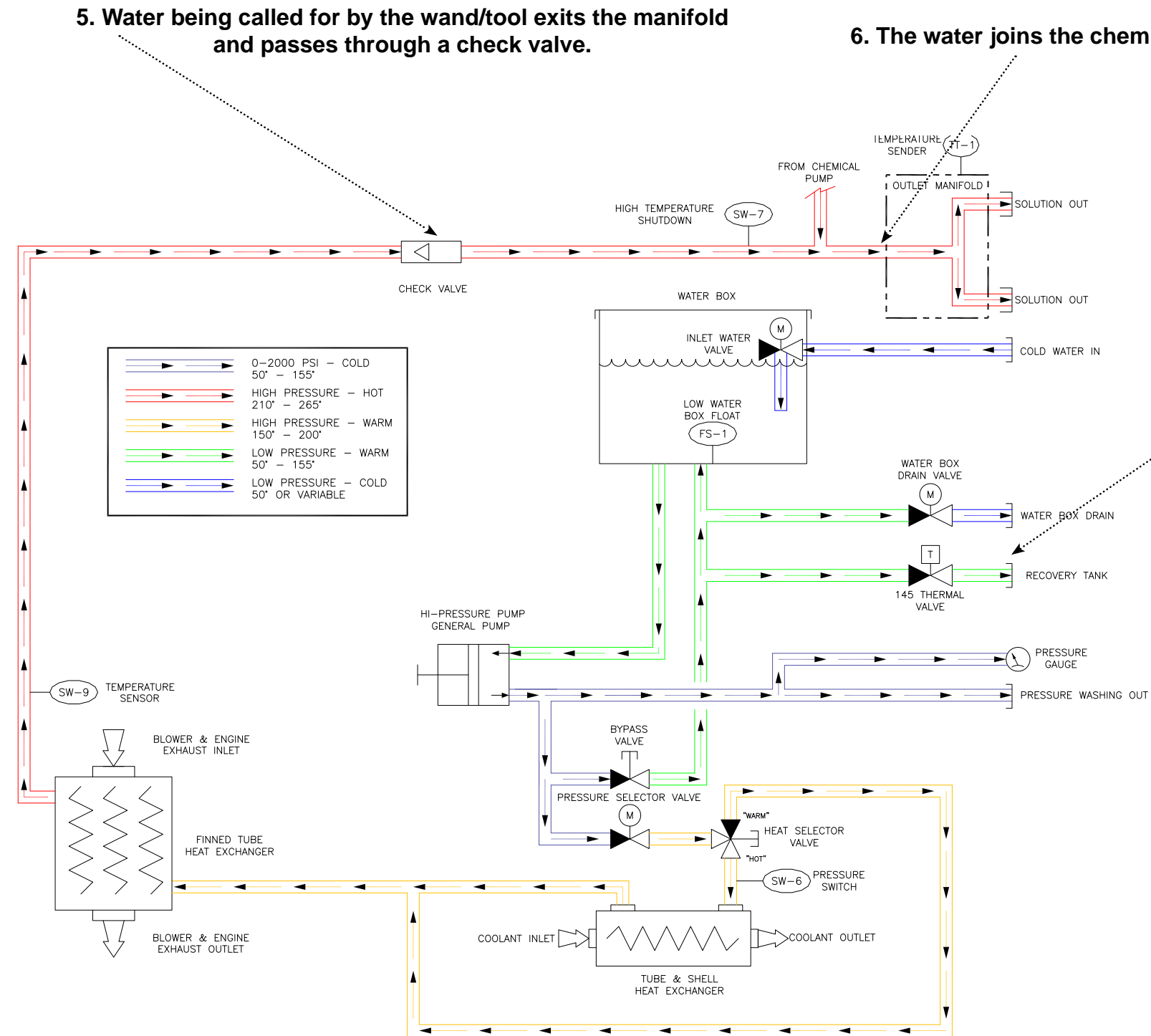

5. Water being called for by the wand/tool exits the manifold and passes through a check valve.

6. The water joins the chemical where the solution is created.

4. Water that is recirculated through the pressure regulator back to the water box travels past a thermovalve.

This thermovalve monitors the water box temperature.

When the controller senses the water in the water box has reached its set point, it opens the low pressure thermovalve on the side of the water box and closes once the temperature drops back below the set point.

Figure 6-3. Annotated Water, Chemical and Solution Flow Diagram - View 3 of 3
7459

8. After being pressurized, the chemical travels through the chemical flow valve and is injected into the high pressure stream. This solution then exits the front of the truckmount and is delivered to the cleaning tool.

7. Chemical is pressurized by the diaphragm chemical pump attached to the head of the water pump. This pump pulls the chemical from the chemical jug, or soap jug, through the chemical flow meter.

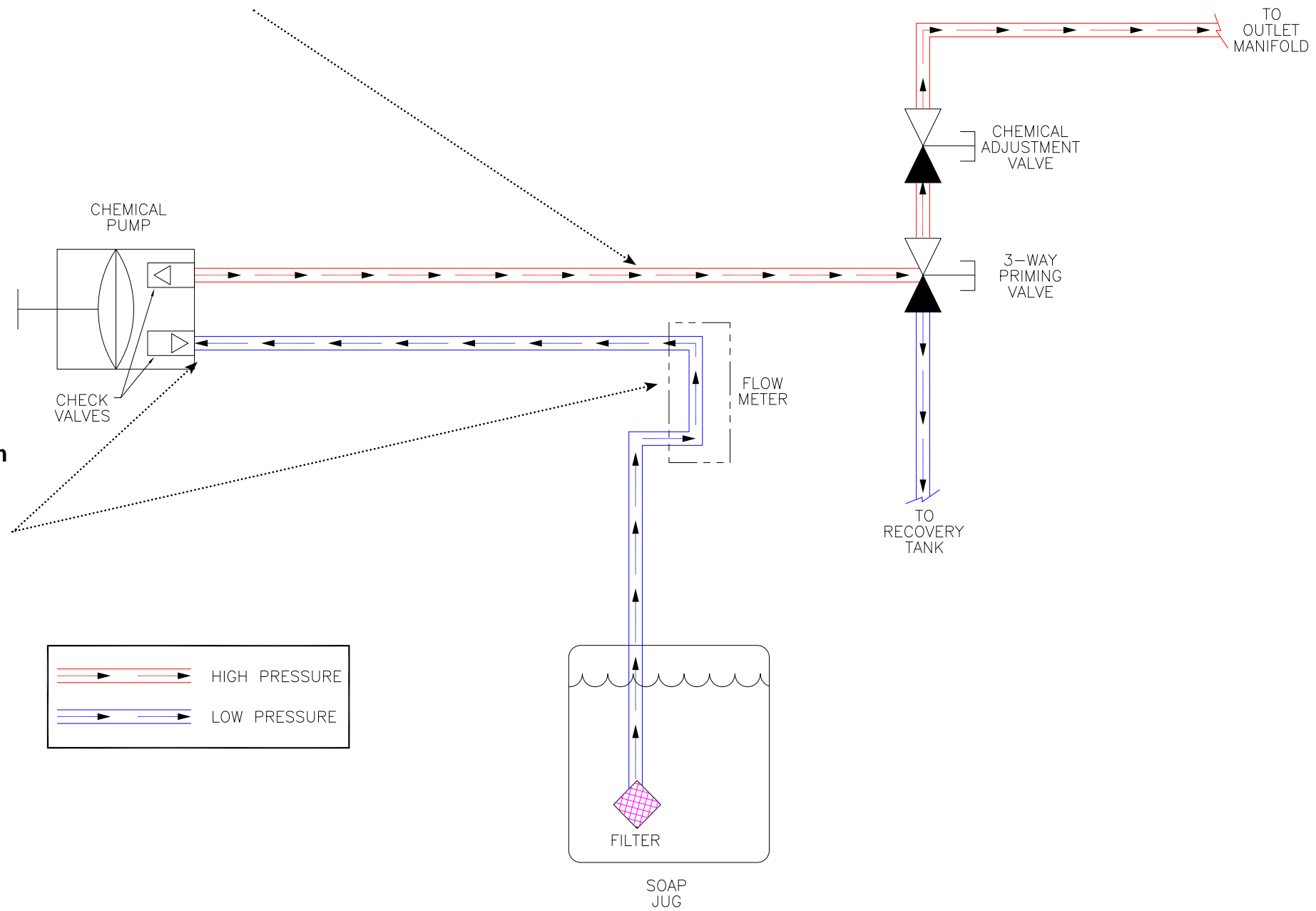

TITAN 575

Figure 6-4. Water, Chemical and Solution Flow Diagram - Larger View
7459

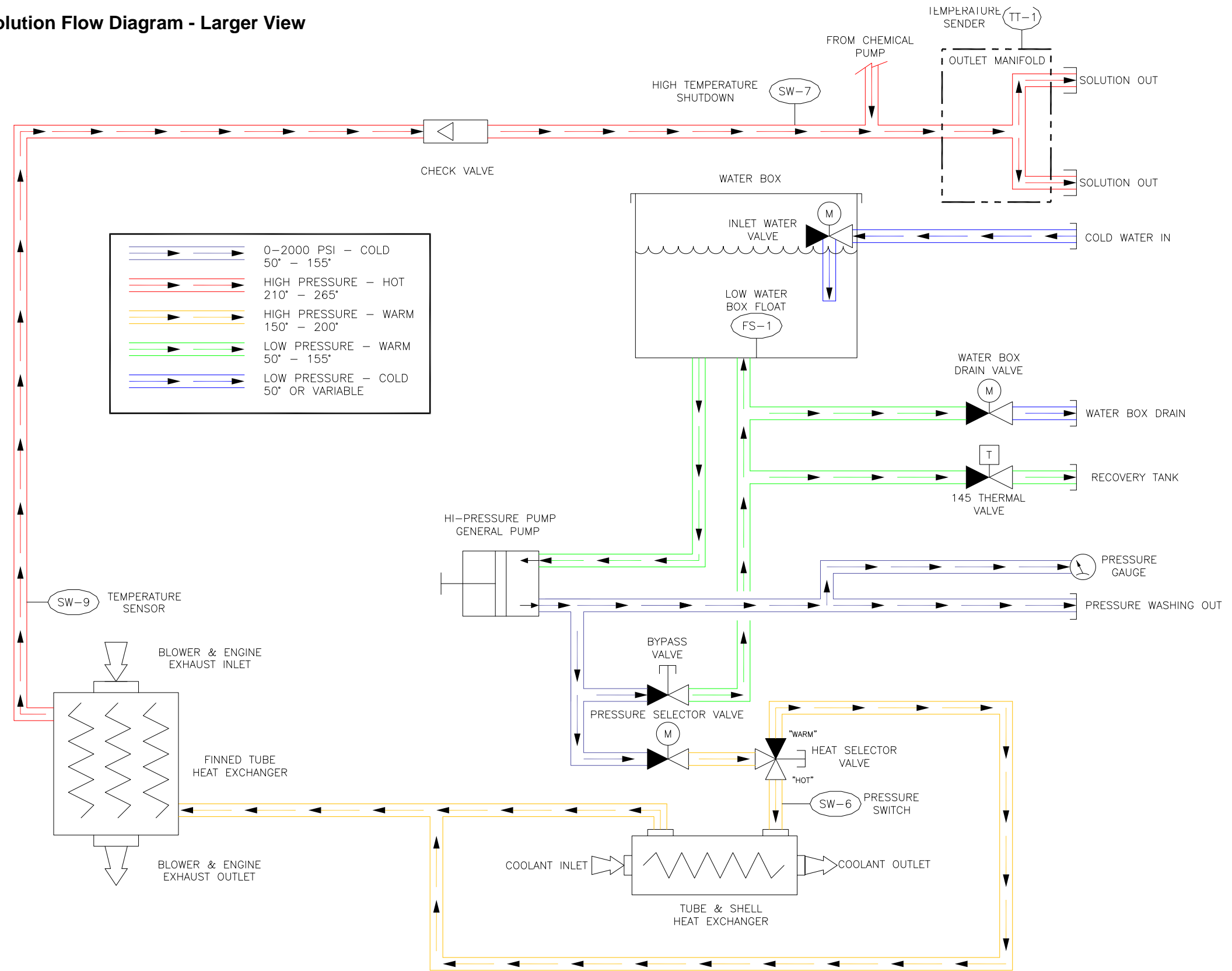
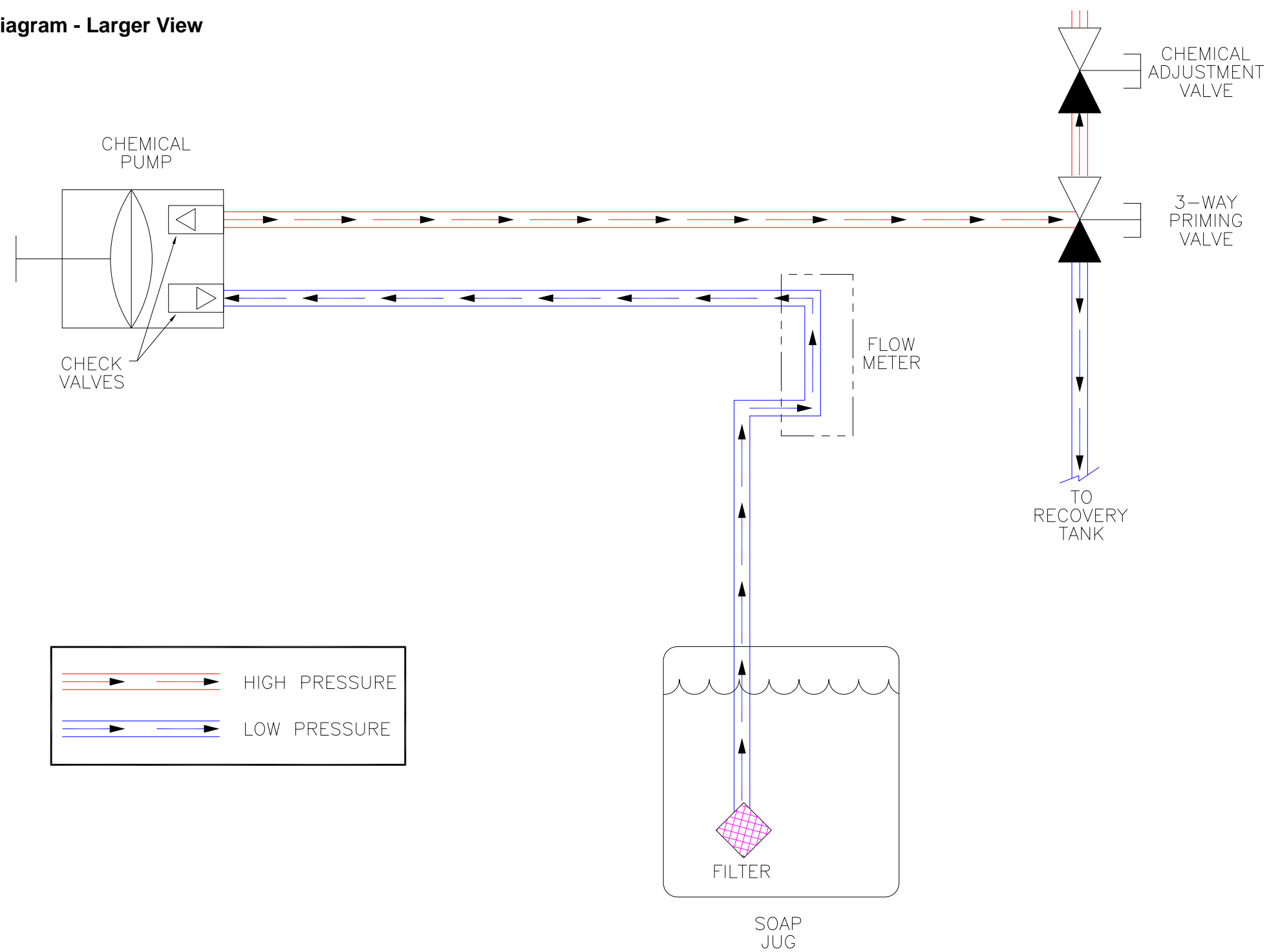
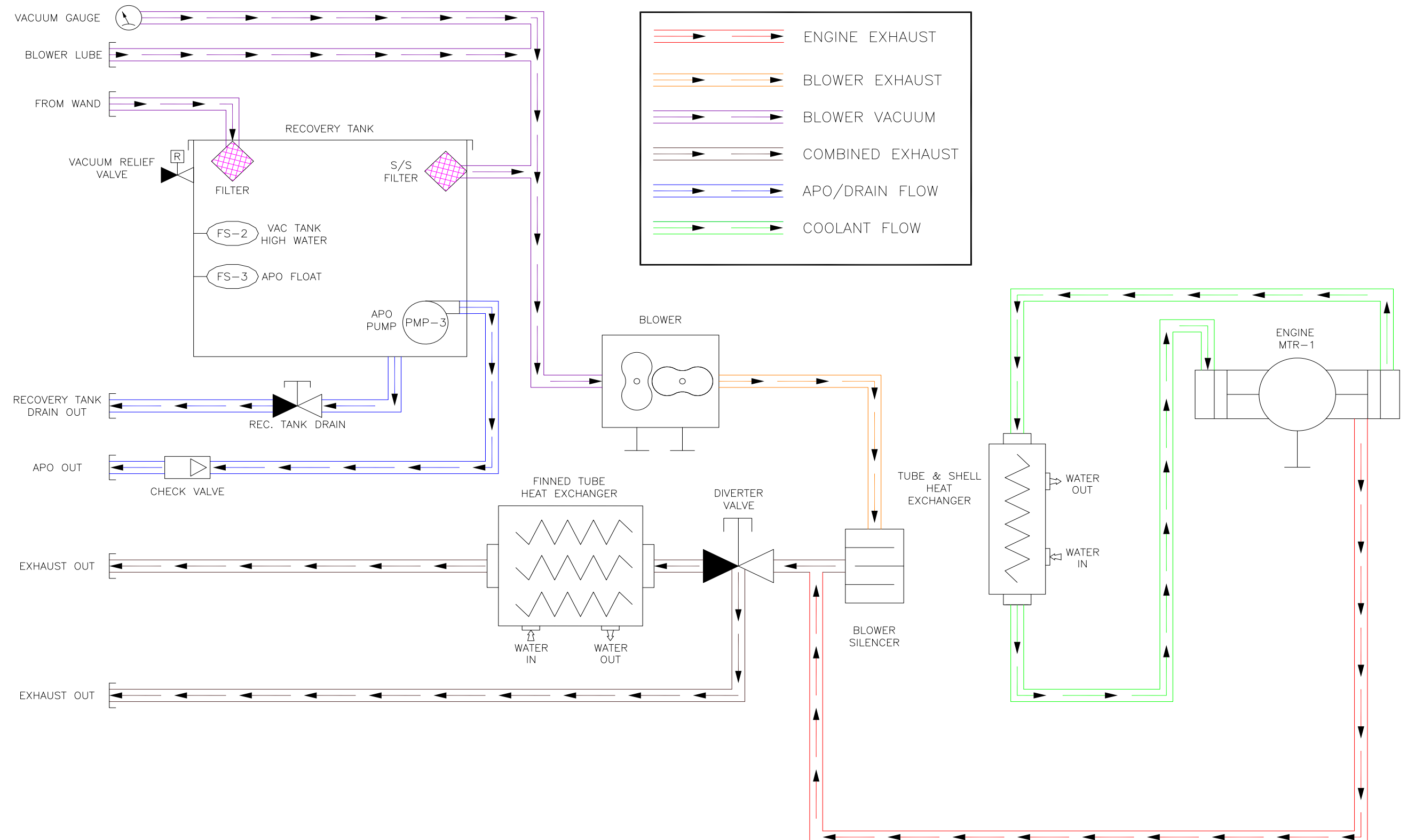

Figure 6-5. Chemical Flow Diagram - Larger View
7459



TITAN 575

Figure 6-6. Exhaust Flow Diagram
7459



7 - Electrical System

This section describes how the electrical system functions in the following manner:

- Electrical System Information
- Electrical Schematic
- Wiring Diagram

ELECTRICAL SYSTEM INFORMATION

The Titan 575 electrical system operates on 12 - 14 V DC which is provided by the battery. Battery levels are maintained by a 40-Amp alternator mounted on the engine.

NOTICE

When a new battery is installed, check that it is properly charged before installation or damage to the charging system may occur.

TITAN 575

Figure 7-1. Electrical Schematic 8580

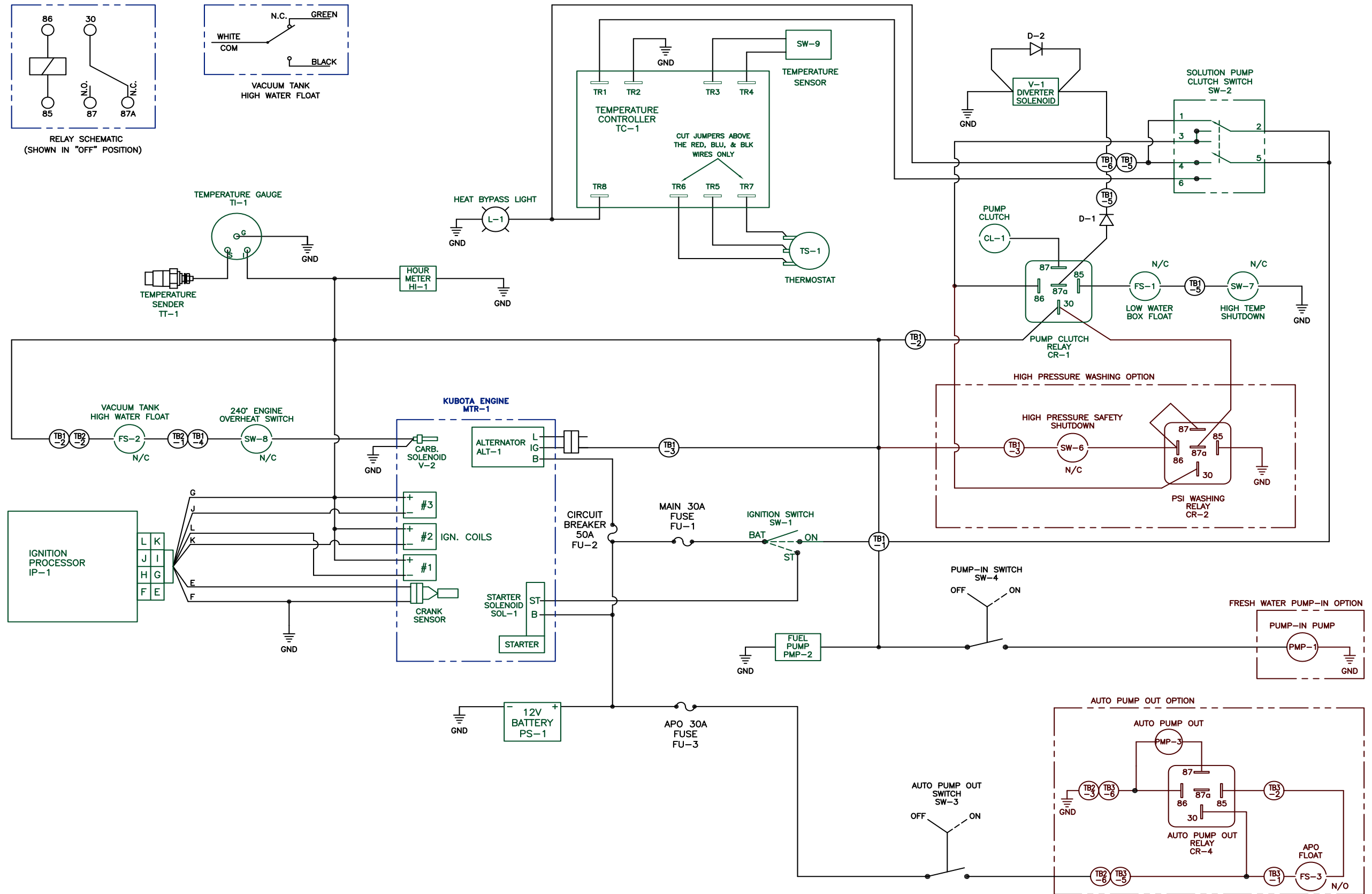
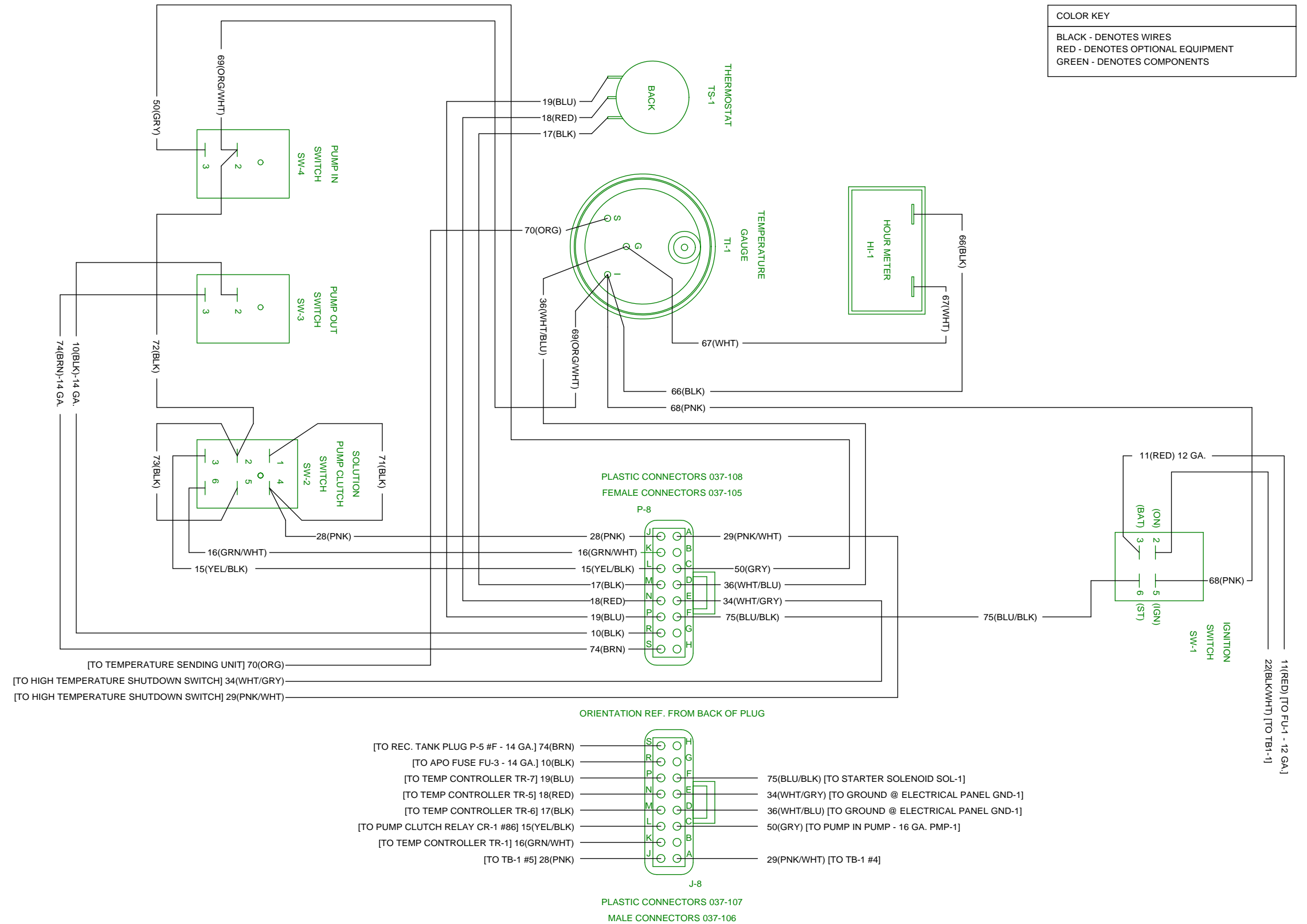

Figure 7-2. Wiring Diagram - View 1 of 3
8579

*ALL WIRES ARE 18 GAUGE UNLESS OTHERWISE STATED



TITAN 575

Figure 7-3. Wiring Diagram - View 2 of 3
8579

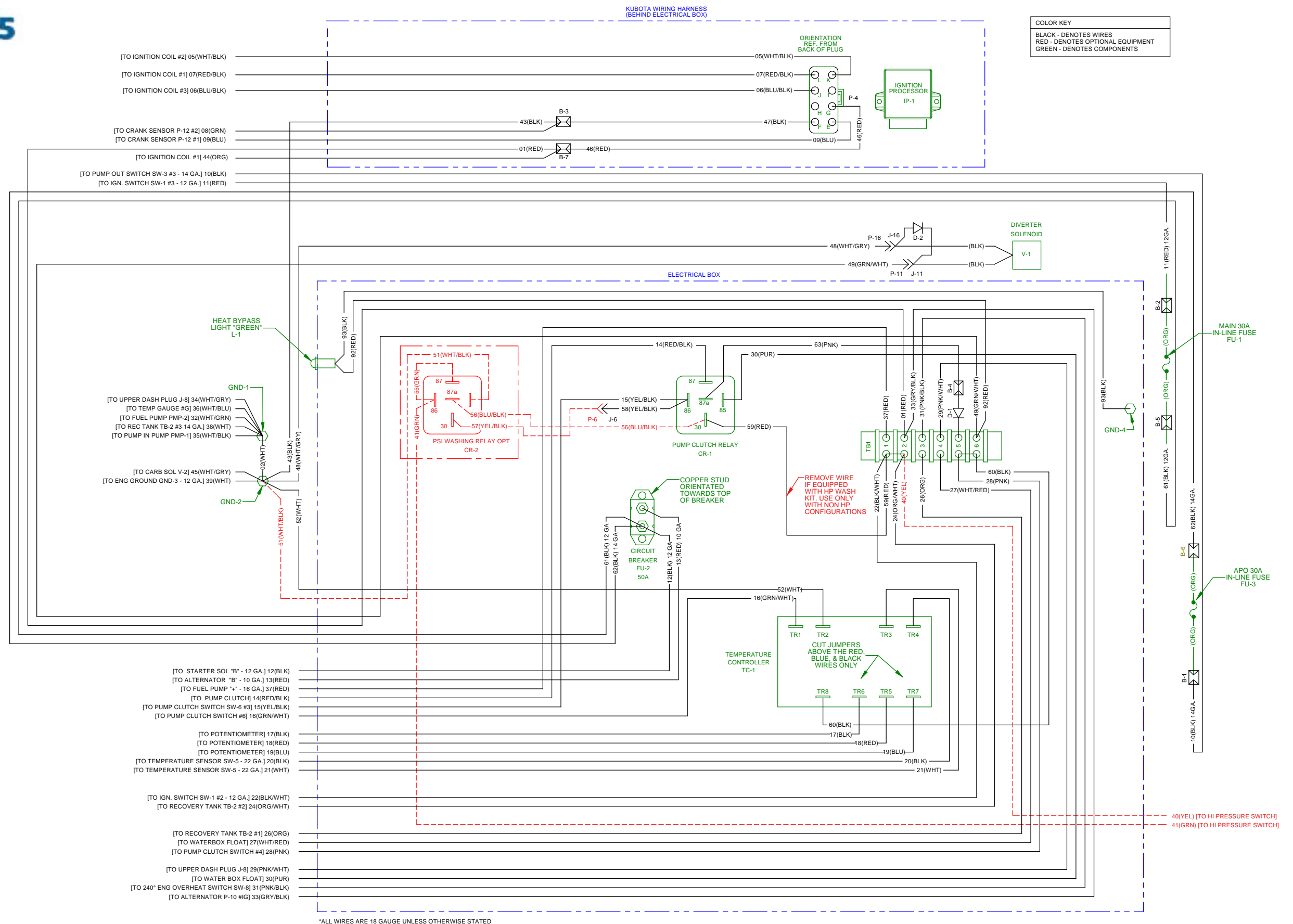
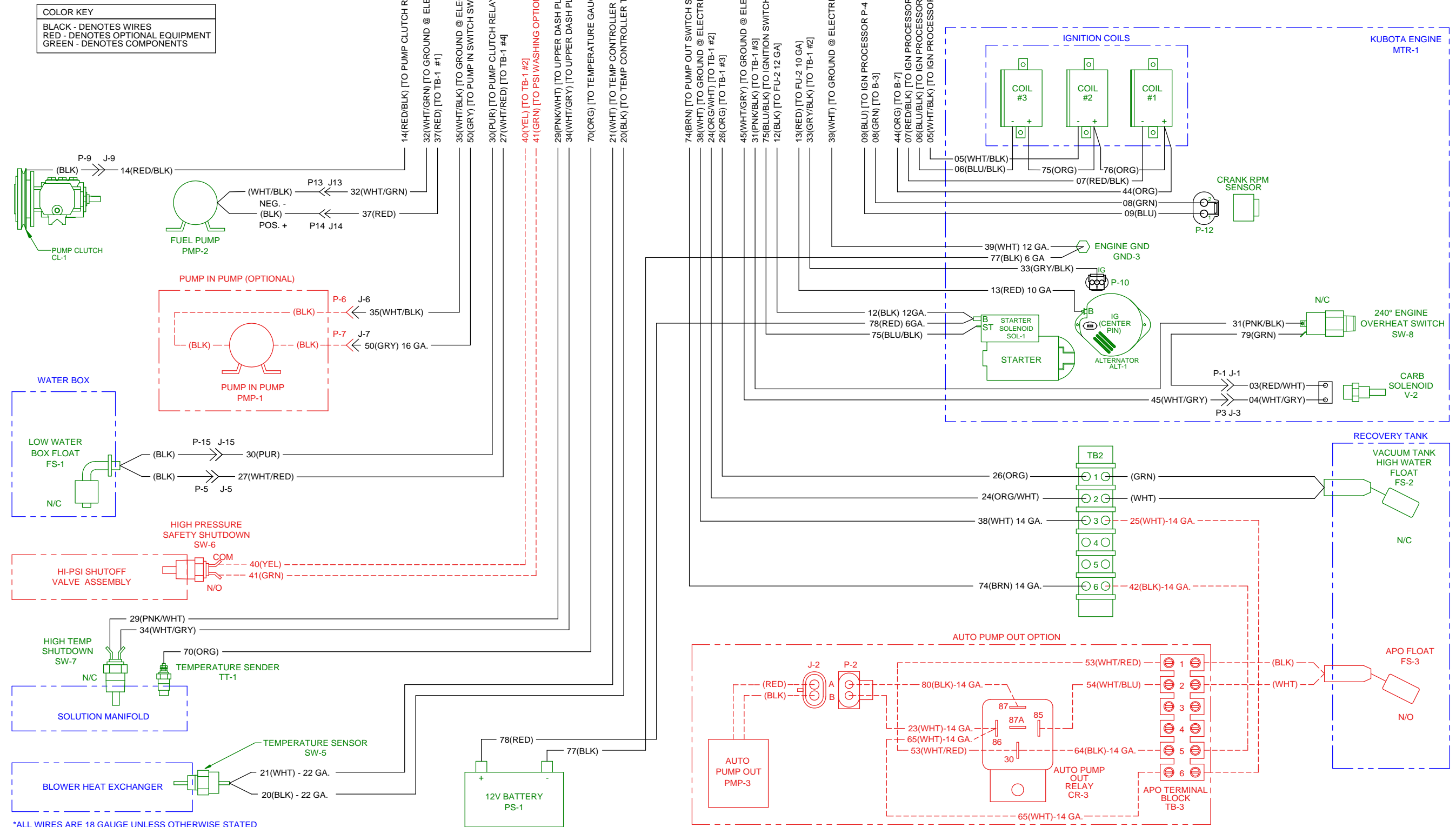

Figure 7-4. Wiring Diagram - View 3 of 3
8579



TITAN 575

8 - Systems Troubleshooting

This section describes the standard troubleshooting procedures in the following areas:

- Heating System
- Chemical System
- Engine
- High Pressure System
- Vacuum System

TITAN 575

HEATING SYSTEM

1. The truckmount overheats and shuts down

Possible Cause	Solution
1.1. Faulty sensor	Inspect the engine overheat switch and test for functionality.

2. Unable to achieve normal cleaning solution temperature

Possible Cause	Solution
2.1. Temperature control knob is turned down.	Inspect the knob. Adjust if necessary.
2.2. The thermostatic valve is faulty.	Inspect the thermostatic valve and test for functionality.
2.3. Excessive solution flow at tool.	The cleaning tool jet is too large or worn. Inspect the jet. Replace if necessary.
2.4. The heat exchanger has hard water scale buildup.	Descale the system.
2.5. The heat exchanger has blockage on the inlet side.	Inspect the interior of heat exchanger. Remove the debris and clean as necessary.
2.6. The heat selector valve is in the wrong position.	Move the heat selector valve to the "HOT" position.

CHEMICAL SYSTEM

1. System will not prime

Possible Cause	Solution
1.1. The check valves in chemical pump are faulty.	Remove the valves and inspect. Clean or replace as necessary.
1.2. The chemical pump diaphragm is faulty.	Remove and inspect. Replace as necessary.
1.3. The check valve in high pressure pump is faulty (piston to which chemical pump is attached).	Remove the valve and inspect. Clean or replace as necessary.
1.4. The filter on feed line in chemical jug is clogged.	Inspect and clean.
1.5. The feed line from chemical jug is loose, pinched or damaged.	Inspect and repair.
1.6. The chemical selector valve is faulty.	Inspect the valve for leaks between ports. Replace as necessary.

2. Chemical flow is unstable or low

Possible Cause	Solution
2.1. Air is in the lines	Check that all fittings and connections are tight and in good condition. Repair or replace as necessary.
2.2. The filter screen in the chemical jug is partially obstructed.	Inspect and clean.
2.3. The chemical selector valve is faulty.	Inspect the valve for leaks between ports. Replace as necessary.
2.4. The chemical metering valve is faulty.	Remove and inspect the valve. Clean or replace as necessary.
2.5. The high pressure check valve is faulty.	Remove and inspect the valve. Clean or replace as necessary.

3. Chemical is present in water box

Possible Cause	Solution
3.1. The chemical pump diaphragm is faulty.	Remove and inspect the chemical pump diaphragm. Replace as necessary.
3.2. The high pressure check valve is faulty.	Remove and inspect the valve. Clean or replace as necessary.

TITAN 575

ENGINE

1. The engine will not turn over

Possible Cause	Solution
1.1. A loose or corroded battery terminal.	Clean and tighten the battery terminal connections.
1.2. The battery is dead.	Recharge or replace the battery. Test the charging system. Repair if necessary.
	CAUTION Do not attempt to jump start the truckmount from a running vehicle. The amperage output from an automobile will damage the charging system of the truckmount.
1.3. The main fuse is blown.	Check the main fuse.
	If the fuse is blown, inspect the electrical system for worn or shorted wires. Repair or replace as necessary.
1.4. The vacuum blower has seized.	Attempt to turn the coupler by hand. If it will not turn refer to the Vacuum System Troubleshooting Subsection (page 8-9).
1.5. The ignition switch is faulty.	Test to see if there is power both to and from the switch. Refer to the Electrical Section of this manual (page 7-1).
1.6. The starter solenoid is faulty.	Test to see if there is power to solenoid with ignition in "START" position. Refer to Electrical Section (page 7-1).
1.7. The starter motor is faulty.	Test to see if there is power to the motor with the ignition in "START" position. Refer to the Electrical Section (page 7-1)..
1.8. None of the above.	Refer to a qualified service technician for further troubleshooting.

2. The engine turns over but will not start.

Possible Cause	Solution
2.1. The recovery tank is full	Drain the tank.
2.2. The recovery tank float is faulty.	Inspect the float. Repair or replace as necessary.
2.3. The engine ignition system is faulty.	Refer to a qualified service technician for further troubleshooting.
2.4. Fuel is not reaching the carburetor.	Test for power to the fuel pump. Refer to Electrical Section.
	If power is present, inspect the fuel pump. Replace if necessary.
	Inspect the fuel lines between the source and the carburetor. Repair or replace as necessary.
2.5. The engine is flooded.	Remove spark plug and dry.
2.6. The spark plugs are worn or dirty.	Inspect and replace as necessary.
2.7. None of the above.	Refer to a qualified service technician for further troubleshooting.

NOTICE

Engine should be adjusted to run at 3,000 rpm under a vacuum load of 12" Hg.

3. The Engine will not come up to normal operating rpm

Possible Cause	Solution
3.1. Excessive load on the engine.	Inspect and clean the recovery tank filters.
	Inspect the recovery tank to the blower hose. Repair or replace as necessary.
3.2. Excessive back pressure on the engine exhaust.	Inspect for blockage in the heat exchanger. Clean or replace as necessary.

TITAN 575

4. Runs rough at high speed

Possible Cause	Solution
4.1. The spark plug(s) are faulty.	Remove and inspect the plugs. Clean or replace as necessary.
4.2. The spark plug wire(s) are faulty.	Inspect the wires and connectors for damage or loose connections. Repair or replace as necessary.
4.3. Inadequate fuel supply to the carburetor.	Check for blockage in the filter. Repair or replace as necessary.
4.4. Poor connection to coils.	Verify there is a good contact with each of the wires to the coils.

5. Runs rich (black smoke)

Possible Cause	Solution
5.1. A dirty air filter	Inspect and replace as necessary.
5.2. Excessive back pressure	Inspect for a clogged heat exchanger, dirty air filter or a partially opened choke.

6. Engine overheats

Possible Cause	Solution
6.1. Poor ventilation in the van	Open all the van doors.
	Install a roof vent in the van.
	Remove any dividers or other objects impeding airflow around the truckmount.
6.2. Low oil level	Check the level and fill as necessary.
6.3. Excessive back pressure on the engine exhaust	Inspect for blockage in the heat exchanger. Clean or replace as necessary.
6.4. Low coolant	Check radiator level
	Check overflow bottle level
6.5. Poor coolant mixture	Check the coolant with a test to determine mixture; adjust as necessary.

HIGH PRESSURE SYSTEM

1. The pump will not come up to normal cleaning pressure

Possible Cause	Solution
1.1. The pressure adjusting valve is faulty.	Inspect the valve. Repair or replace if necessary.
1.2. Worn seals or valves in the pump.	Test the pump output volume directly from the pump at normal running rpm. If the volume is below the manufacturer's specifications, replace the seals and inspect for defective valves.
1.3. The pump rpm is too low.	Check for a loose pump belt. Adjust or replace as necessary.
	Check the engine rpm and adjust as necessary to 3,000 rpm under a 12" Hg vacuum load.

2. No pressure reading on gauge

Possible Cause	Solution
2.1. The pump belt is broken.	Inspect and replace if necessary.
2.2. The gauge is faulty.	Replace the gauge.

3. The psi gauge reads normal (low pressure from wand)

Possible Cause	Solution
3.1. Restriction in the cleaning tool	Inspect the tool jet(s) and clean or replace as necessary.
	Inspect any filters in the cleaning tool and clean or replace as necessary.
3.2. Faulty quick connect in the system	Inspect each quick connect and replace as necessary.
3.3. Restriction in one of the solution hoses	Remove the quick connects and inspect hoses. Clean or replace as necessary.
3.4. Hard water deposits restricting the system	Descale the truckmount.

TITAN 575

4. Pressure pulsation

Possible Cause	Solution
4.1. Chemical pump is not primed.	Prime the chemical pump.
4.2. Air leak between the water box and pump.	Check all the hoses and fittings for cuts, breaks, cracks, etc. Repair as necessary.
4.3. The check valve(s) in the pump are faulty.	Remove each valve and inspect for correct operation. See Machine Maintenance (Section 5).

5. Water box empty or fills slowly

Possible Cause	Solution
5.1. Restriction in the water supply system.	Inspect the supply system from the source through the incoming quick connect.
5.2. The float valve in the water box is faulty.	Disassemble and inspect the valve. Repair or replace as necessary.

6. The water box overflows

Possible Cause	Solution
6.1. The float valve in the water box is faulty.	Disassemble and inspect the valve. Repair or replace as necessary.
6.2. The float has absorbed water and lost buoyancy.	Replace as necessary.
6.3. The float has come out of adjustment.	Adjust the float as necessary.

VACUUM SYSTEM

1. Weak vacuum at wand. The gauge reads normal.

Possible Cause	Solution
1.1. Blockage in the hoses or wand tube	Disconnect the hoses and check for an obstruction.
1.2. Excessive length of hose connected to the truckmount	Do not attach excessive lengths of hose.

2. Weak vacuum

Possible Cause	Solution
2.1. Air leak somewhere in the vacuum system	Check the vacuum relief valve for proper adjustment.
	Carefully check all the vacuum hoses for a cut or break.
	Check the recovery tank lid gasket.
	Make sure the recovery tank drain valve is fully closed.
2.2. The vacuum blower is turning too slowly.	Check the rpm of the engine. Adjust as necessary to 3,000 rpm under a 12" Hg. vacuum load.
2.3. The vacuum gauge is defective.	Test the gauge and replace if necessary.

3. The vacuum gauge reads too high with no hoses attached

Possible Cause	Solution
3.1. The filter in recovery tank is clogged.	Remove and clean or replace as necessary.
3.2. The hose from recovery tank to the vacuum blower is collapsed internally.	Inspect and replace as necessary.

4. Excessive noise produced by the blower

Possible Cause	Solution
4.1. The blower is low on oil.	Inspect the oil levels and replenish as necessary. Note: Running the blower with low oil levels can cause severe damage. If this situation occurs the blower should be inspected by a qualified service technician.
4.2. The vacuum blower has internal damage.	Refer to a qualified service technician.

TITAN 575

5. The vacuum blower is locked and will not turn

Possible Cause	Solution
5.1. Truckmount has been inactive for a period of time and the blower was not properly lubricated prior to final shutdown. Rust has possibly built up on the internal surfaces.	Spray penetrating oil into the blower and let sit for at least one hour. Then very carefully use pipe wrench on the outer diameter of the pulley on the coupler to attempt to free lobes of the blower. Do not use a wrench directly on the blower shaft. If unable to free up the blower in this manner, refer to a qualified service technician.
5.2. There is internal damage to the blower	Refer to a qualified service technician.

6. Water in truckmount exhaust

Possible Cause	Solution
6.1. The recovery tank has been filled with foam or overfilled with water.	Inspect the recovery tank. If full, drain the tank.
	Inspect the high level shutoff switch for proper operation. Clean or replace the switch as necessary.
	If foam is in recovery tank, use defoamer on the carpet being cleaned.
6.2. Condensation in system	This will be more common in cool weather and humid climates. If this is the cause it should dissipate after a few minutes of running.
6.3. The heat exchanger is leaking water.	Inspect and repair or replace as necessary.

9 - Assemblies and Parts Lists

Titan 575 assembly drawings and parts list included in this section are as follows:

- Machine Assembly Parts List
- Frame Assembly Parts List
- Engine Assembly Parts List
- Exhaust Assembly Parts List
- Top Cover Assembly Parts List
- Flywheel Plate Assembly Parts List
- Upper Dash Assembly Parts List
- Electrical Panel Assembly Parts List
- Blower Assembly Parts List
- Pump and Silencer Assembly Parts List
- Pump Assembly Parts List
- Water Box Assembly Parts List
- Lower Dash Assembly Parts List
- Side Cover Assembly Parts List
- Grill Assembly Parts List
- Blower Heat Exchanger Assembly Parts List
- Coolant Heat Exchanger Assembly Parts List
- Diverter Valve Box Assembly Parts List
- By-Pass Valve Assembly Parts List
- 3-Way Valve Assembly Parts List
- Actuator Valve Assembly Parts List
- Hi Pressure Manifold Assembly Parts List
- 70 Gallon Universal Recovery Tank (URT) Assembly Parts List
- 100 Gallon Universal Recovery Tank Assembly Parts List
- 70 Gallon Universal Recovery Tank for 85 Gallon Rotomolded Tank Assembly Parts List
- 100 Gallon Universal Recovery Tank for 85 Gallon Rotomolded Tank Assembly Parts List
- High Pressure Washing Kit - Pump Assembly Parts List
- High Pressure Washing Kit - Lower Left Dash Assembly Parts List
- Recovery Tank Cover with 2 1/2" Port Kit Assembly Parts List
- Hose Routings

TITAN 575

Figure 9-1. Machine Assembly - View 1 of 4
8130

Machine Assembly Parts List

Item	Part Number	Description	Qty
1	---	Assembly, Frame	1
2	000-041-850	Assembly, Side Cover - Machine	2

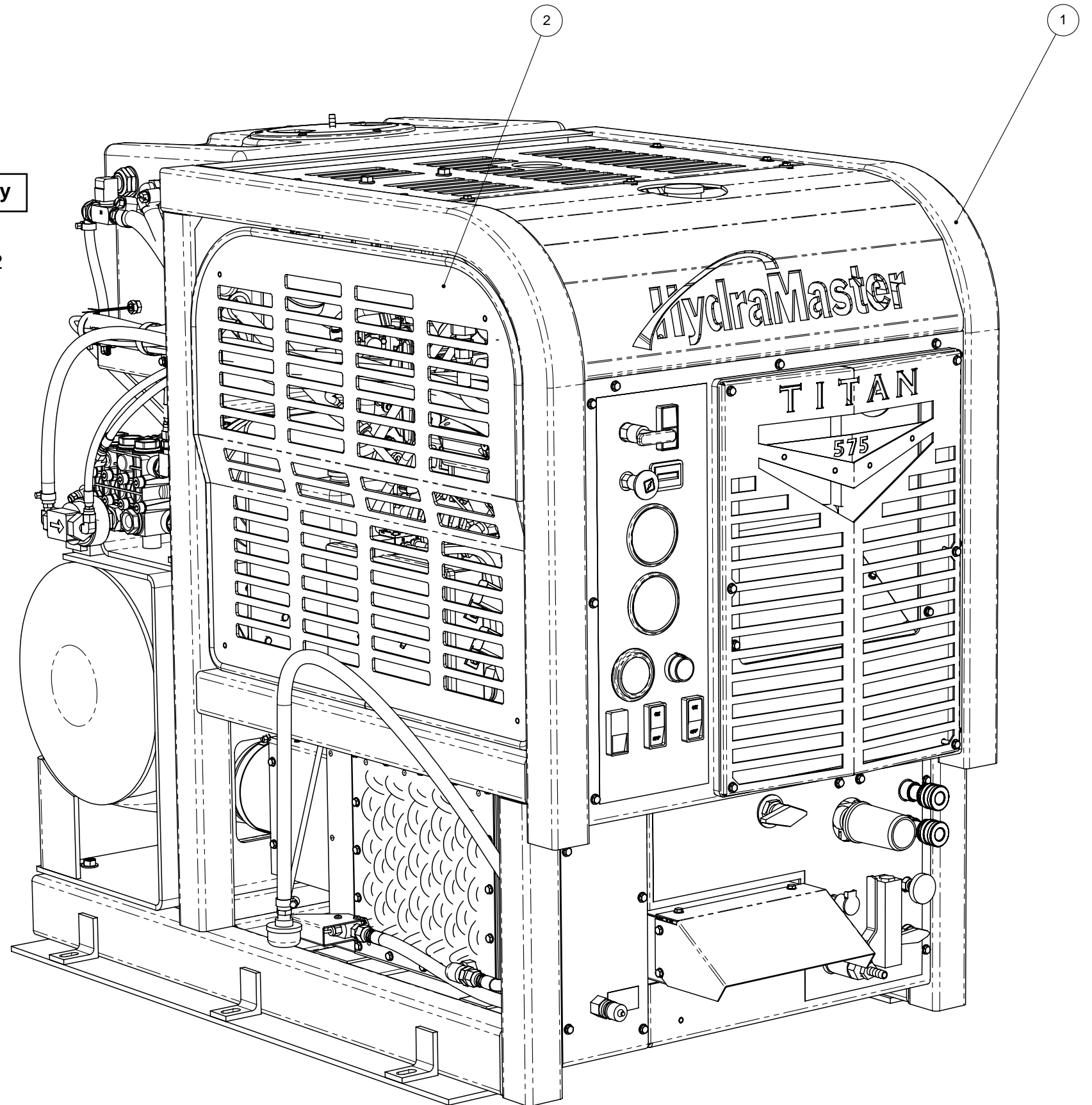
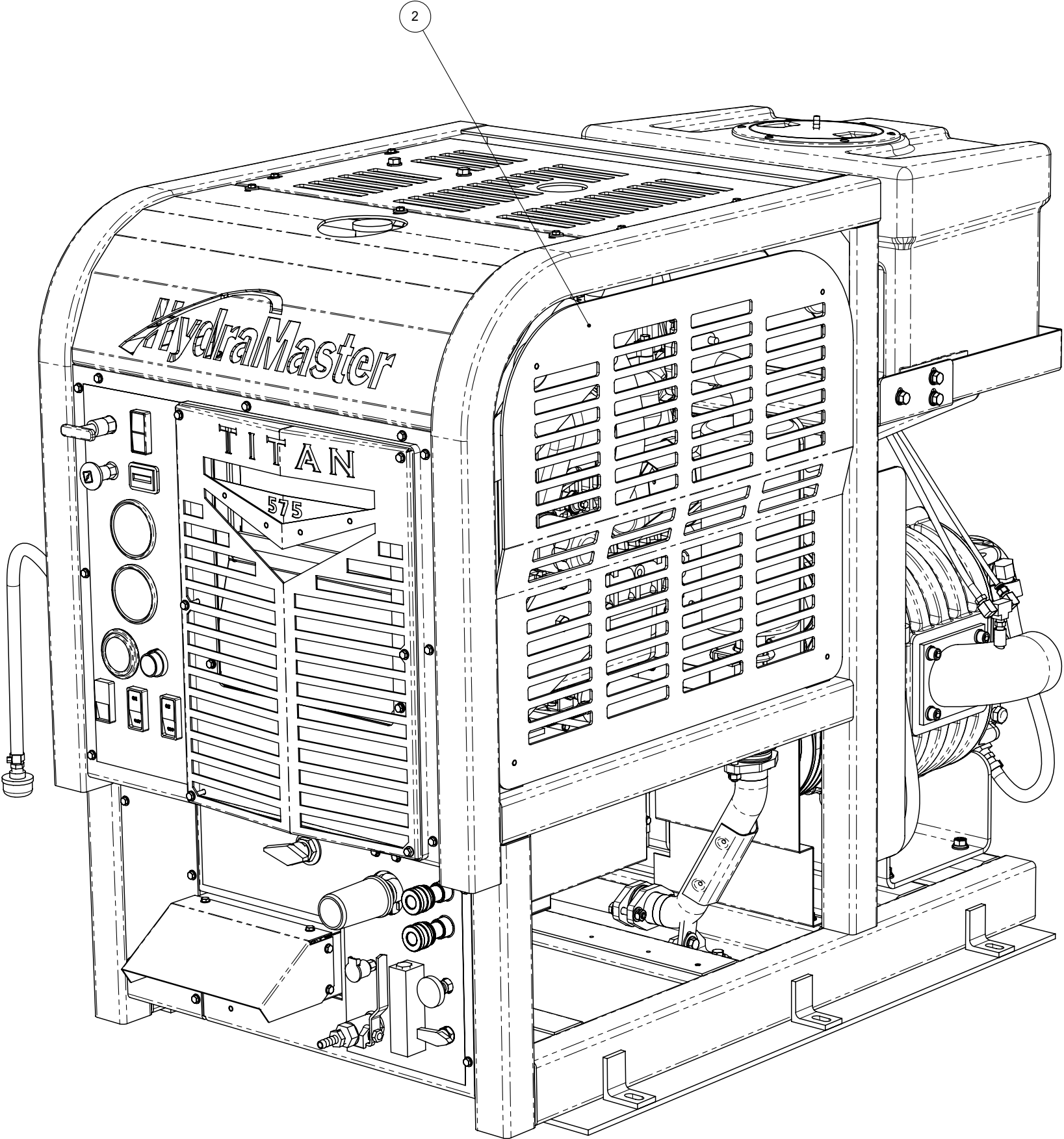

Figure 9-2. Machine Assembly - View 2 of 4
8130



TITAN 575

Figure 9-3. Machine Assembly - View 3 of 4
8130

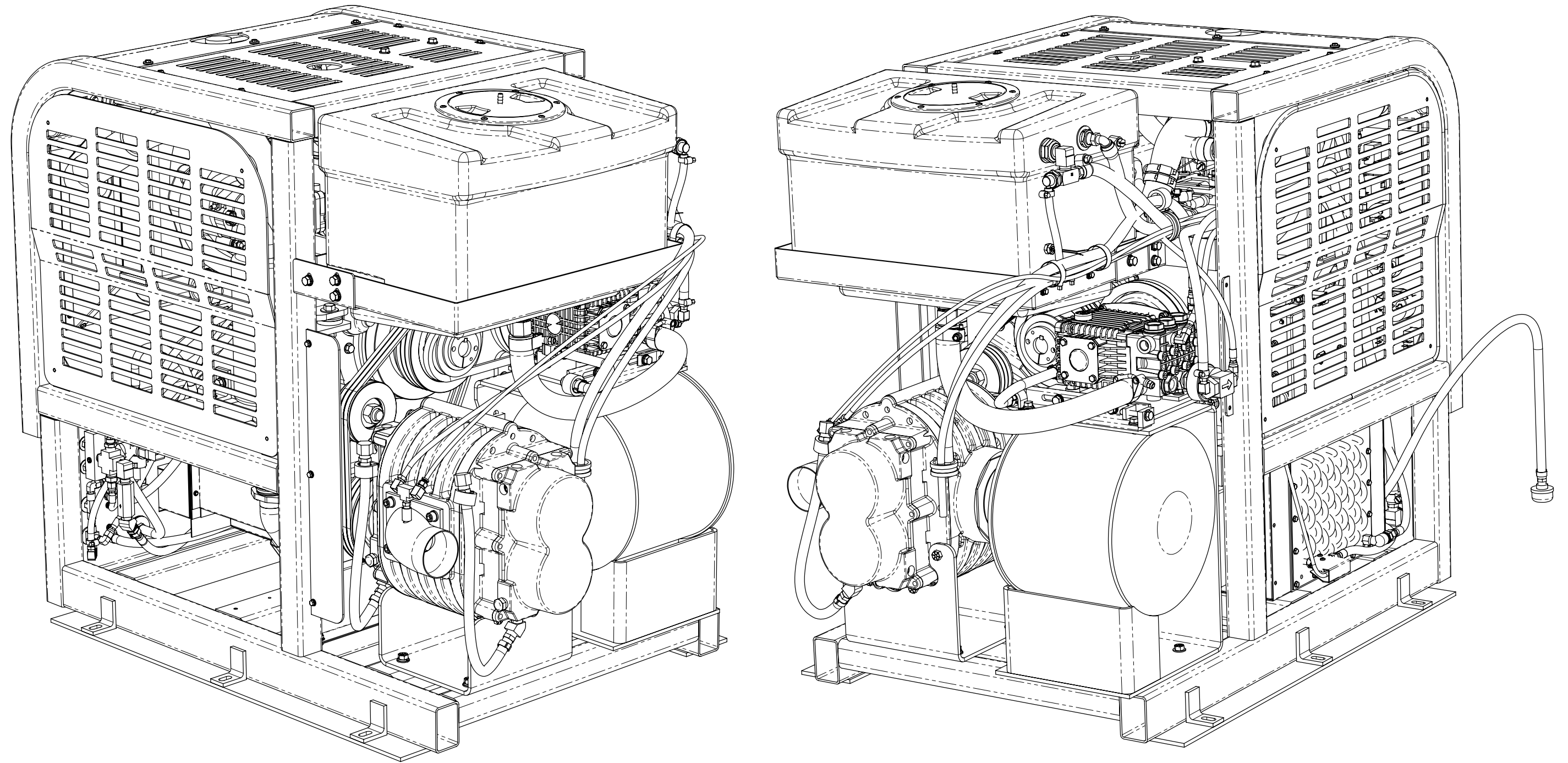
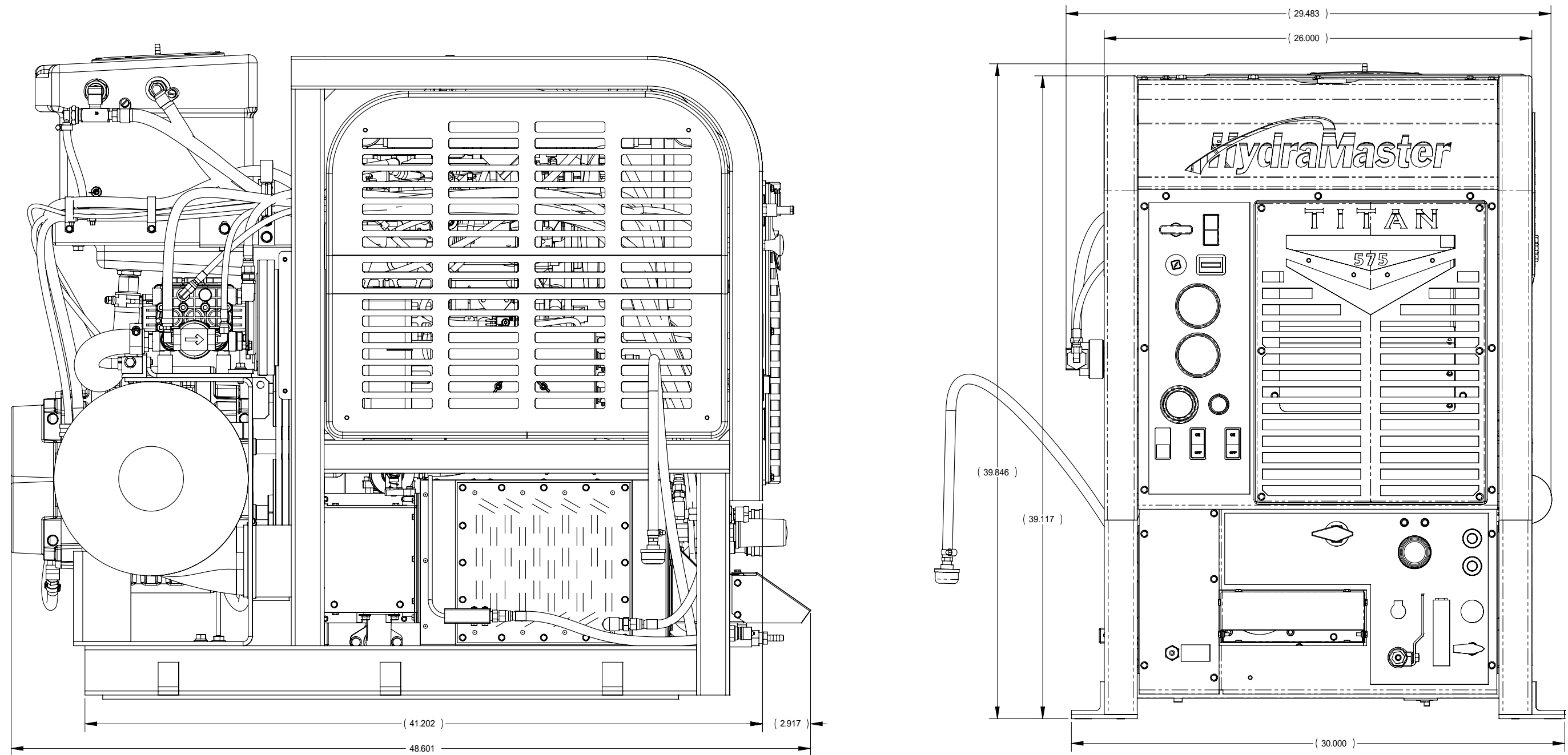

Figure 9-4. Machine Assembly - View 4 of 4
8130



TITAN 575

Figure 9-5. Frame Assembly - View 1 of 5
8131

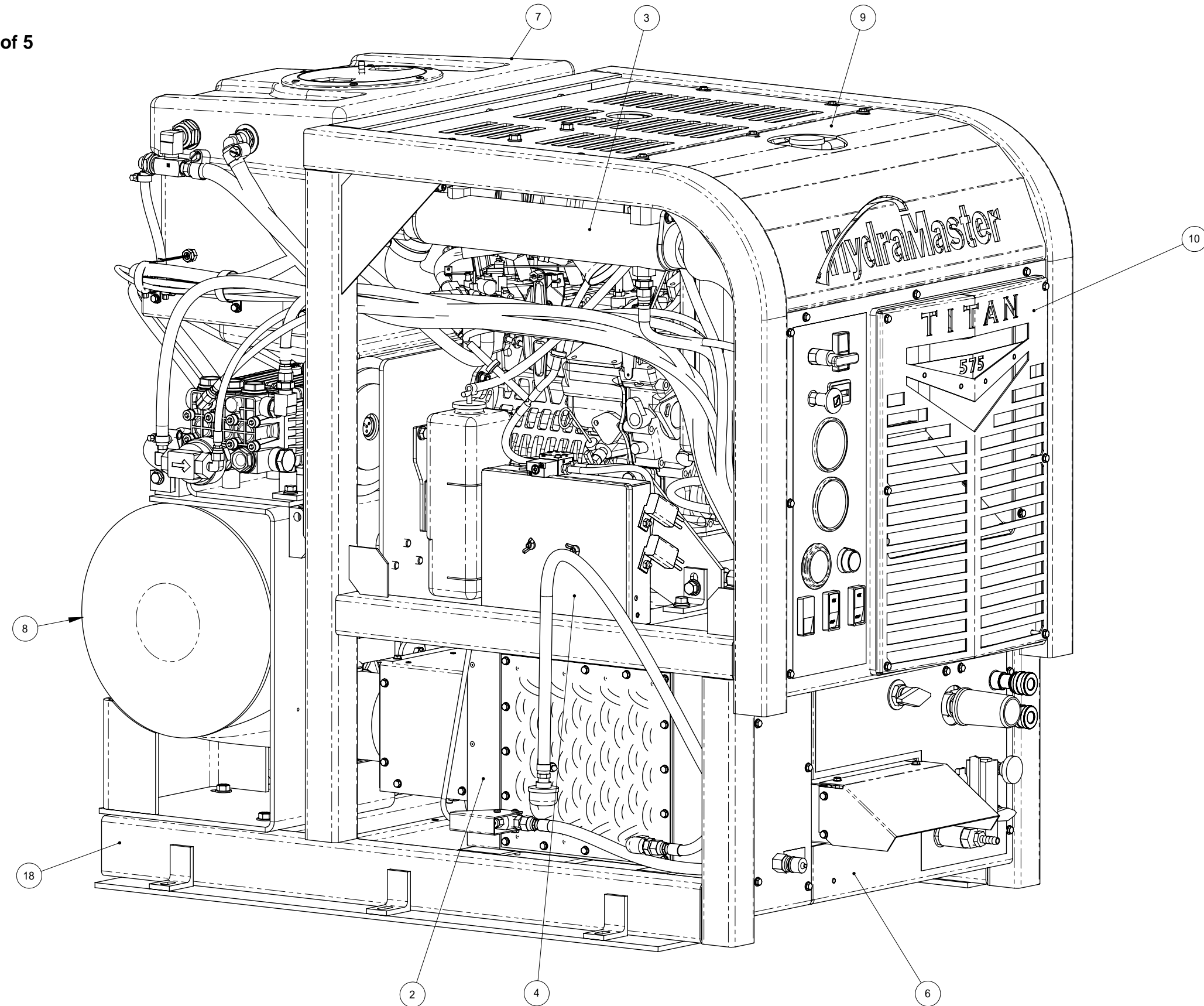
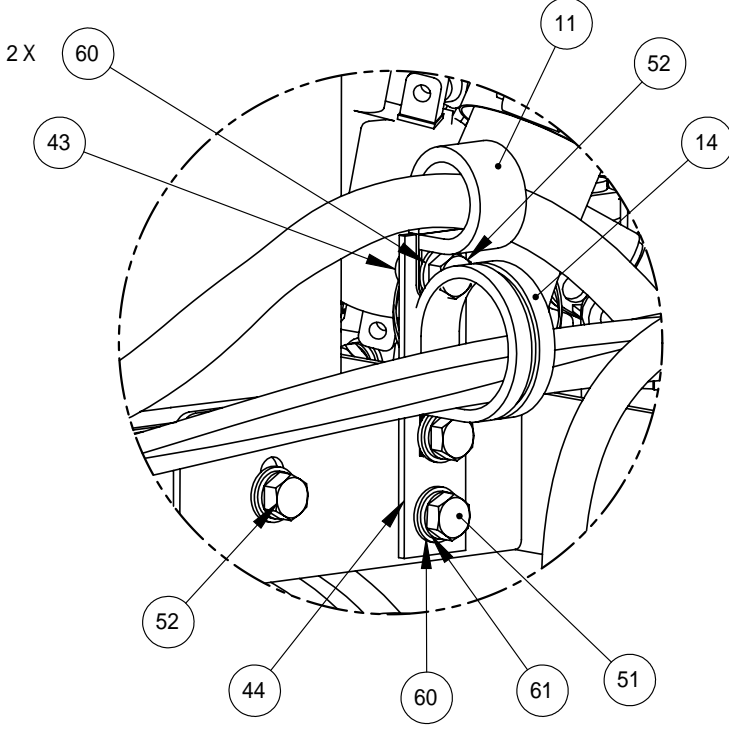
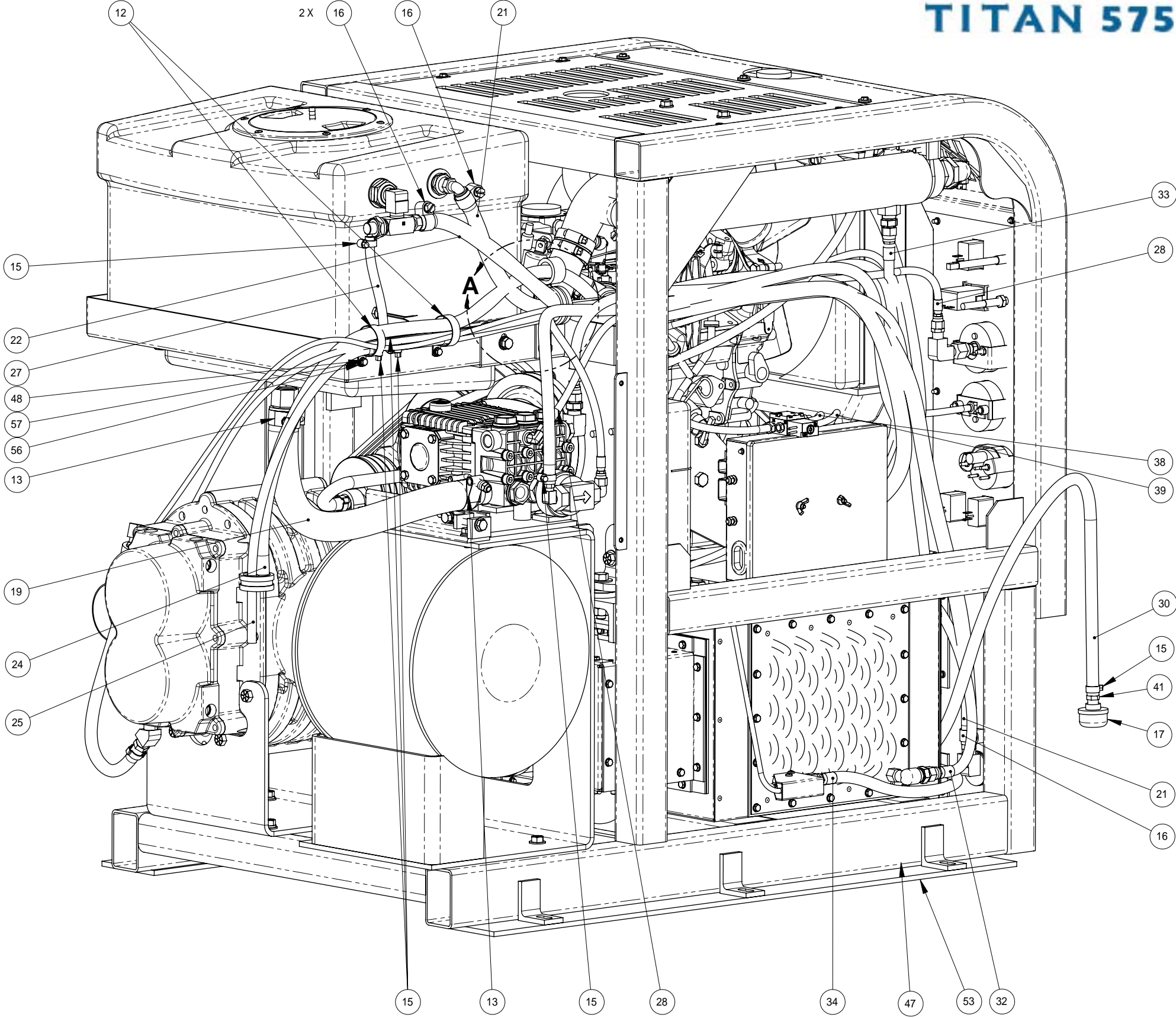

Figure 9-6. Frame Assembly - View 2 of 5
8131



DETAIL A
SCALE 1 : 2



TITAN 575

Figure 9-7. Frame Assembly - View 3 of 5
8131

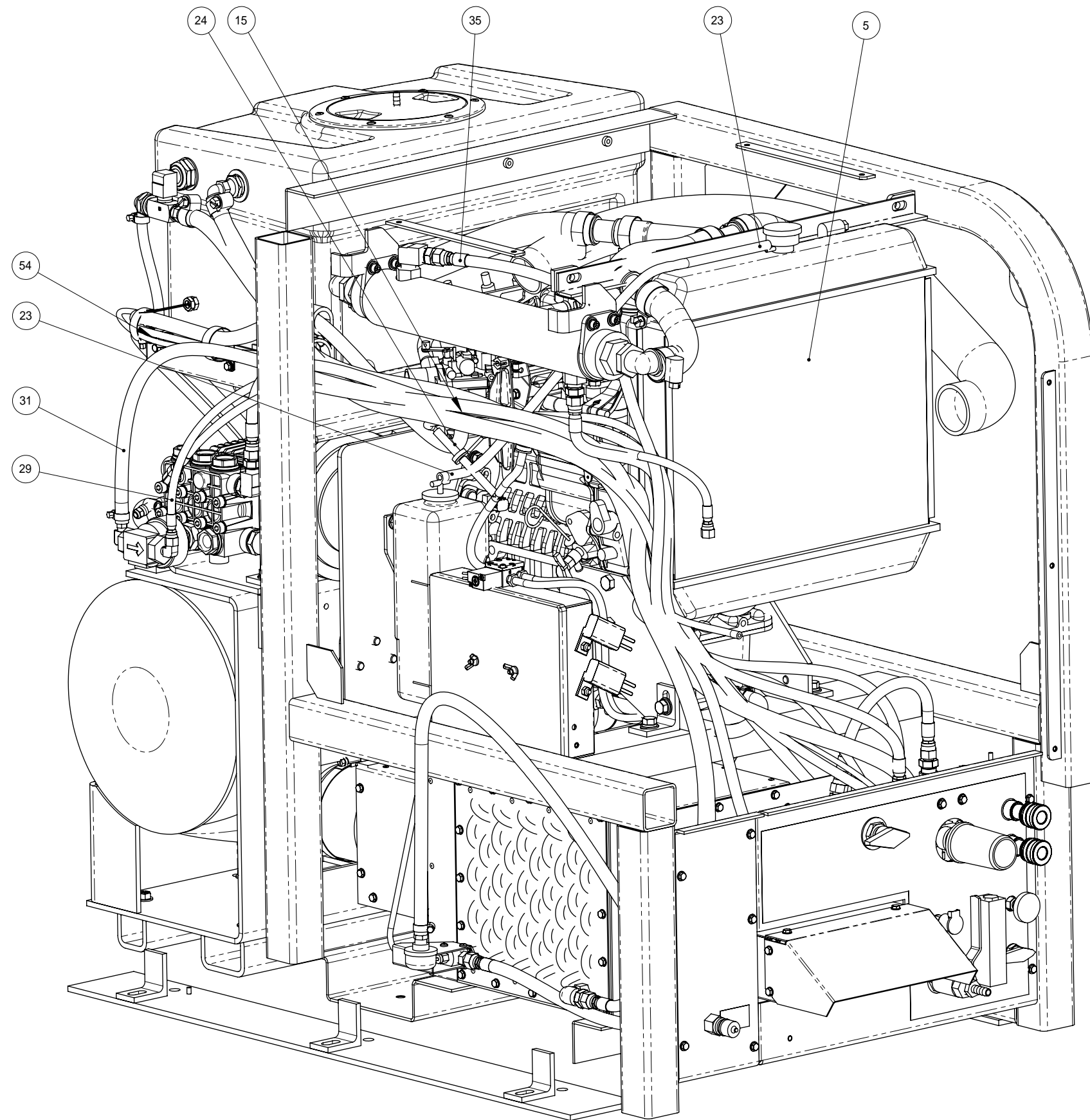
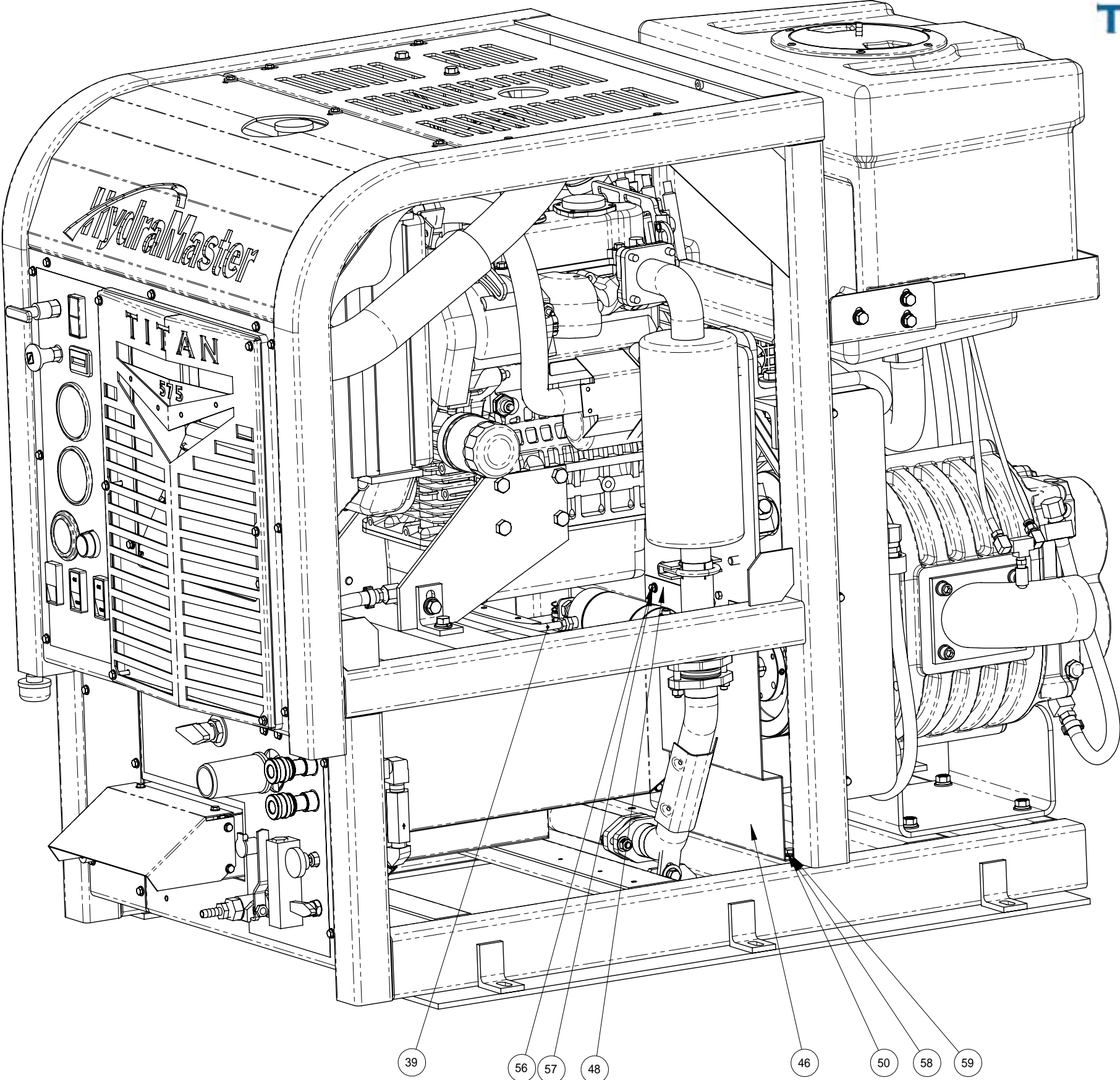
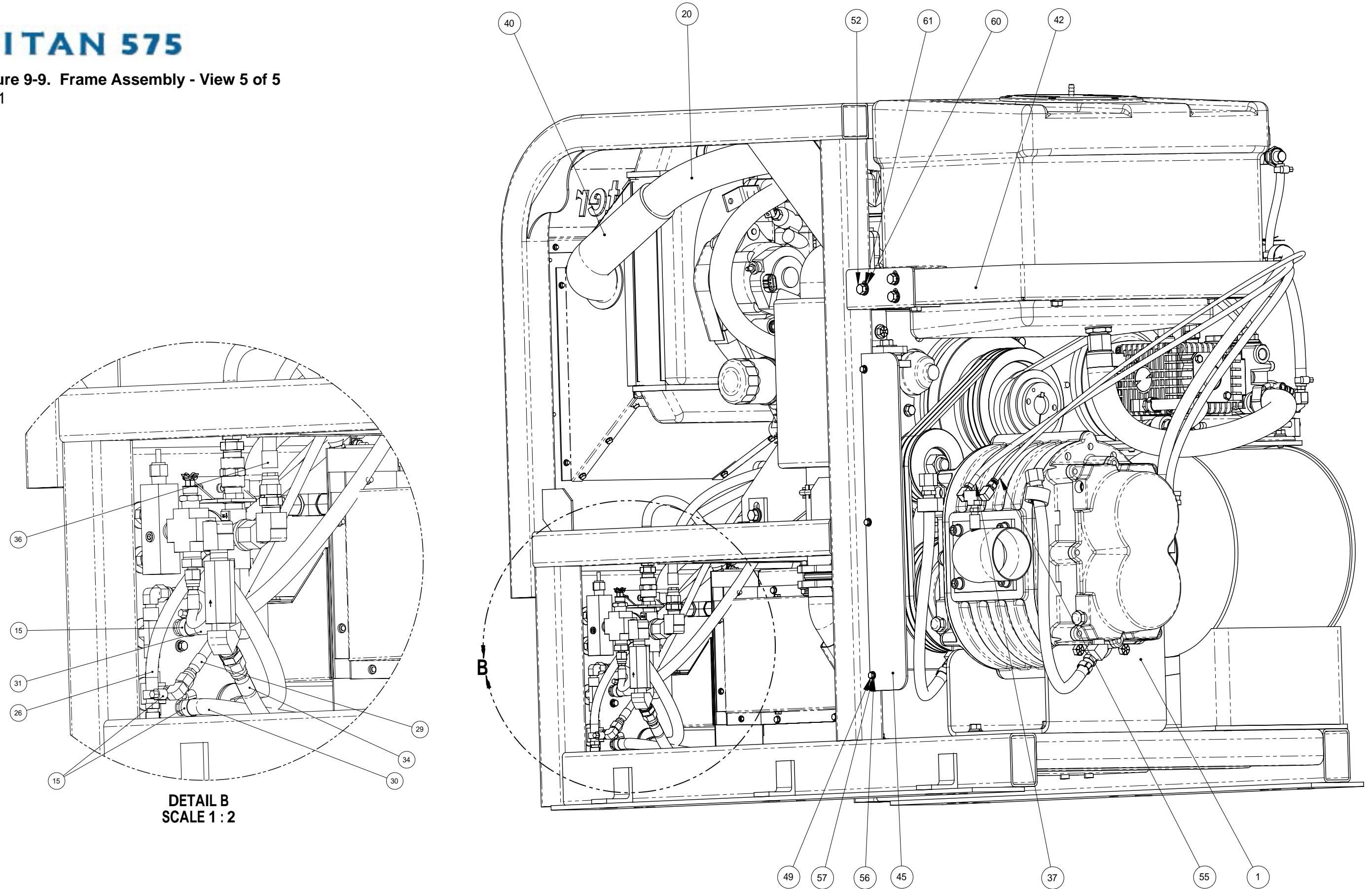

Figure 9-8. Frame Assembly - View 4 of 5
8131



TITAN 575

Figure 9-9. Frame Assembly - View 5 of 5
8131



Frame Assembly Parts List

Item	Part Number	Description	Qty	Item	Part Number	Description	Qty
1	---	Assembly, Blower	1	32	000-068-737	Hose, 3/8" X 14.5" Lg. Teflon w/ JIC Ends	1
2	---	Assembly, Blower Heat Exchanger	1	33	000-068-626	Hose, 3/8" X 28.5" Lg. Teflon w/ JIC Ends	1
3	---	Assembly, Coolant Heat Exchanger	1	34	000-068-821	Hose, 3/8" X 33" Lg Teflon w/ JIC Ends	1
4	---	Assembly, Electrical Panel	1	35	000-068-820	Hose, 3/8" X 40" Lg. Teflon w/ JIC Ends	1
5	610-003-576	Assembly, Engine - Kubota	1	36	000-068-525	Hose, 3/8" X 54" Lg. Teflon w/ JIC Ends	1
6	---	Assembly, Lower Dash	1	37	000-068-030	Hose, 5/32" I.D. Vacuum - Bulk	1
7	---	Assembly, Poly Water Box 8g	1	38	000-068-030	Hose, 5/32" I.D. Vacuum - Bulk	1
8	---	Assembly, Pump & Silencer	1	39	000-068-030	Hose, 5/32" I.D. Vacuum - Bulk	1
9	610-022-575	Assembly, Top Cover	1	40	000-068-920	Hose, Kubota Intake Elbow - Modified	1
10	610-020-576	Assembly, Upper Dash	1	41	000-052-102	Insert, #46 (1/4" NPT X 3/8" Barb)	1
11	000-033-117	Clamp, 1" Cushion Loop w/ 7/16 Mount Hole	1	42	000-092-032	Mount, Water Box Support	1
12	000-033-053	Clamp, 1-1/2" Cushion Loop	2	43	000-094-038	Nut, 5/16"-18UNC Nylock	1
13	000-033-132	Clamp, 1-1/2" T-Bolt	2	44	000-105-564	Plate, Fuel Hose Support	1
14	000-033-135	Clamp, 1-3/4" Cushion Loop w/ 7/16" Hole	1	45	000-108-150	Protector, Belt Guard	1
15	000-033-003	Clamp, Size #4 Mini Hose	10	46	000-108-164	Protector, Belt Heat Shield	1
16	000-033-004	Clamp, Size #6 Mini Hose	4	47	000-143-114	Screw, #10-24UNC X 0.50" Lg. Flat Head Phillips	4
17	000-049-118	Filter, Chemical Inlet High Pressure	1	48	000-143-126	Screw, #10-24UNC X 0.50" Lg. Hex Head	4
18	000-055-190	Frame, Weldment	1	49	000-143-166	Screw, #10-24UNC X 3/8" Lg. Hex Head	3
19	000-068-791	Hose, 1" X 24" Lg. Suction	1	50	000-143-333	Screw, 1/4"-20UNC X 0.50" Lg. Hex Head	2
20	000-068-919	Hose, 1.75" I.D. X 18.75" Lg. Flexible	1	51	000-143-012	Screw, 5/16"-18UNC X 0.75" Lg.	2
21	000-068-018	Hose, 1/2" I.D. - Bulk	1	52	000-143-572	Screw, 5/16-18UNC X 5/8" Lg. Grd. 5 Hex Head	5
22	000-068-018	Hose, 1/2" I.D. - Bulk	1	53	000-154-156	Spacer, Machine Rising 4" X 35"	2
23	000-068-025	Hose, 1/4" Clear - Bulk	1	54	000-052-575	Tee, 1/4"Insert M-M-M GFBN	1
24	000-068-157	Hose, 1/4" Fuel Low Perm Non Fuel Injected Only	1	55	000-125-255	Tubing, 1/4" Blue Nylon - Bulk	1
25	000-068-015	Hose, 1/4" I.D. Rubber - Bulk	1	56	000-174-001	Washer, #10 Flat	7
26	000-068-015	Hose, 1/4" I.D. Rubber - Bulk	1	57	000-174-014	Washer, #10 Lock	7
27	000-068-015	Hose, 1/4" I.D. Rubber - Bulk	1	58	000-174-003	Washer, 1/4" Flat	2
28	000-068-823	Hose, 3/16" X 38" Lg. Teflon w/ JIC Ends	1	59	000-174-019	Washer, 1/4" Lock	2
29	000-068-822	Hose, 3/16" X 66" Lg. Teflon w/ JIC Ends	1	60	000-174-004	Washer, 5/16" Flat	8
30	000-068-326	Hose, 3/8" I.D. Clear Braid - Bulk	1	61	000-174-018	Washer, 5/16" S/S Lock	6
31	000-068-326	Hose, 3/8" I.D. Clear Braid - Bulk	1				

TITAN 575

Figure 9-10. Engine Assembly -
View 1 of 3
8132 Rev. B

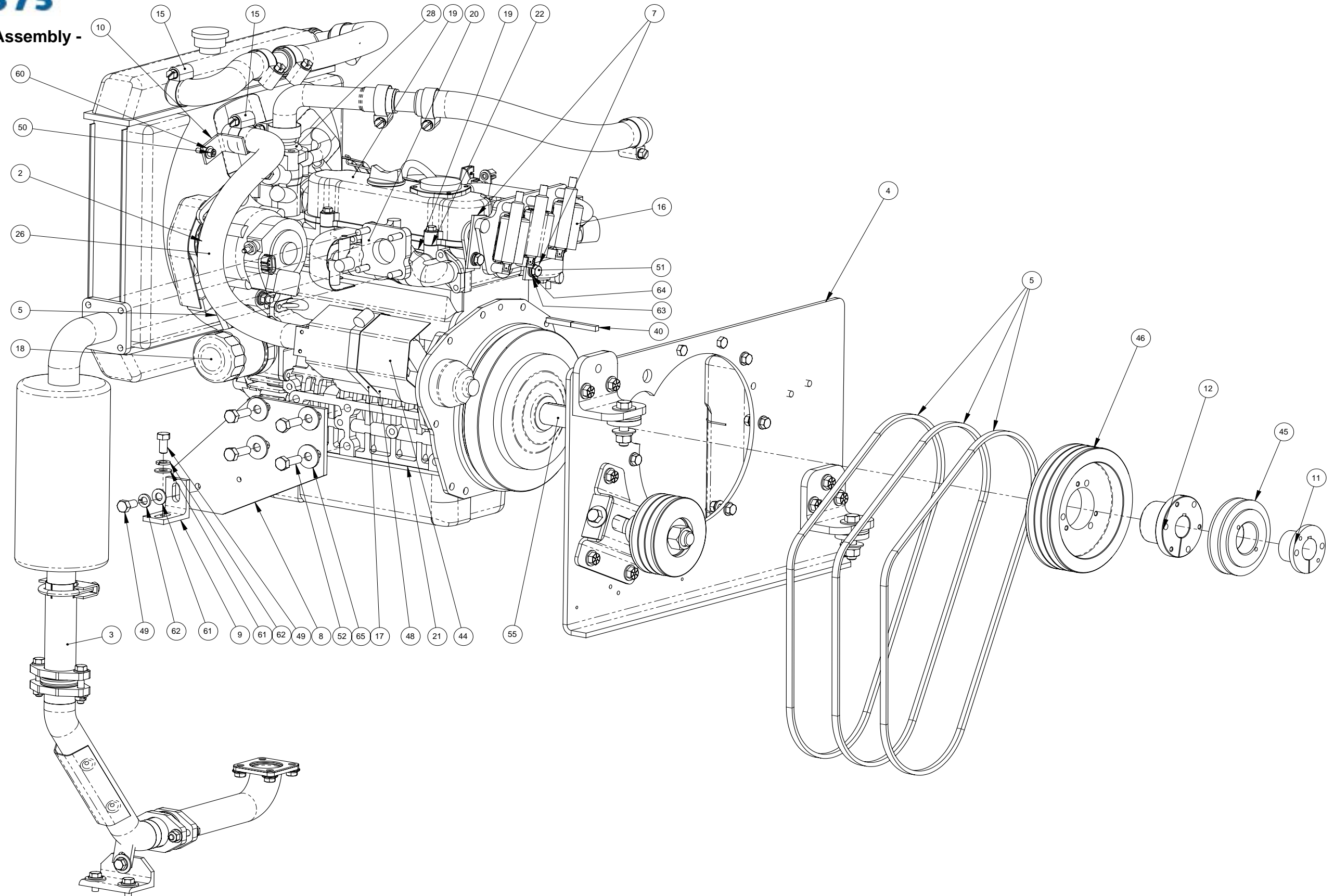
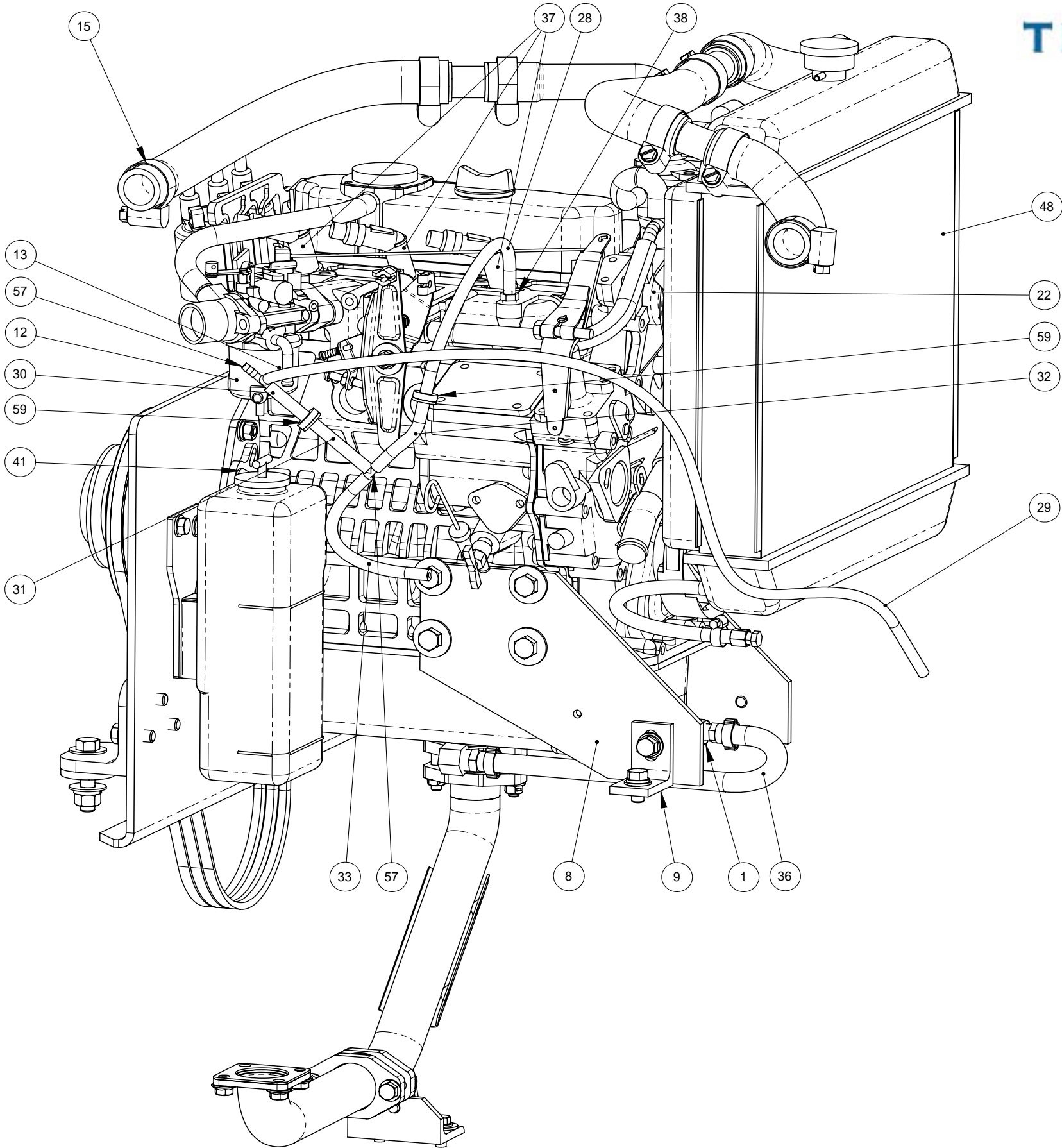
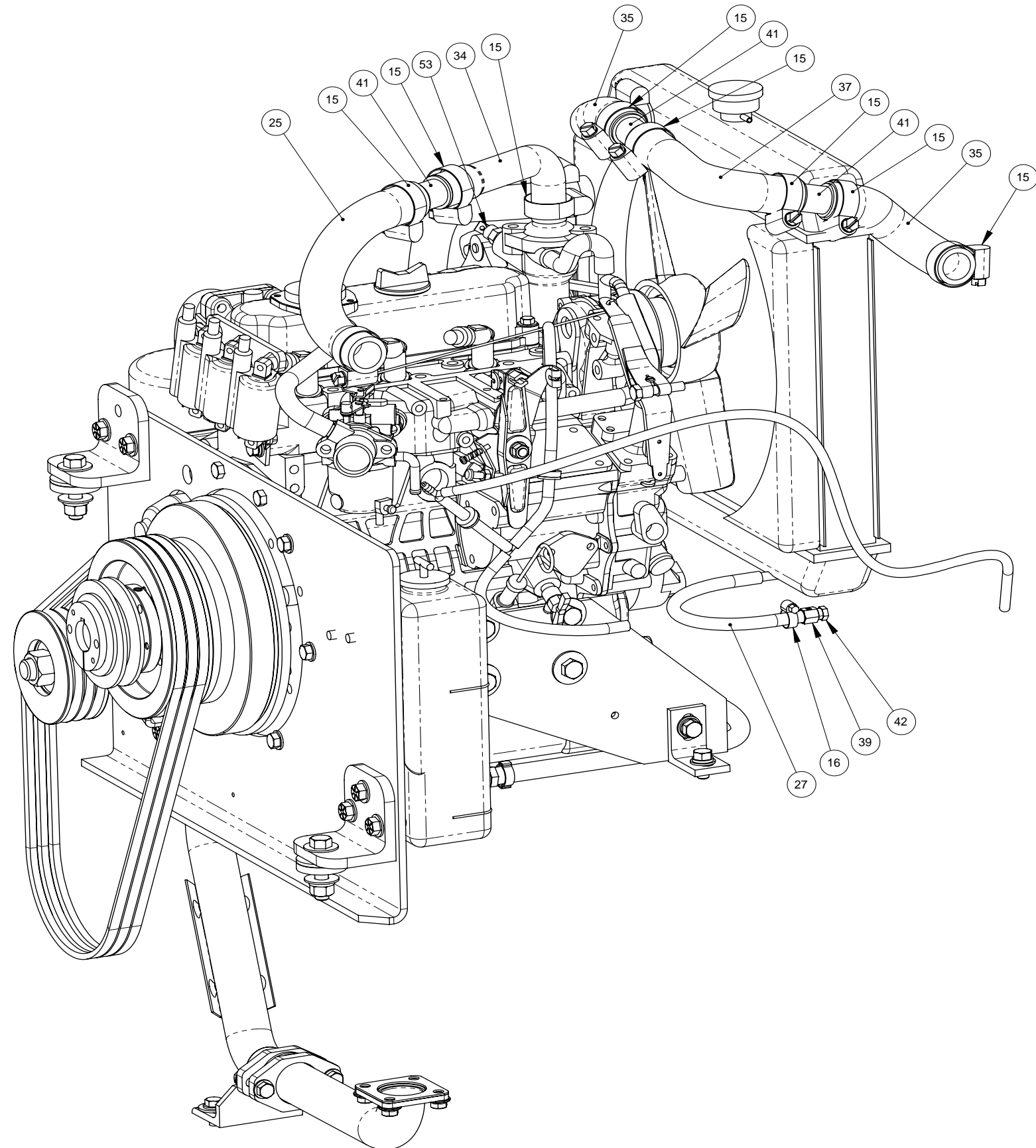

Figure 9-11. Engine Assembly - View 2 of 3
8132 Rev. B



TITAN 575

Figure 9-12. Engine Assembly - View 3 of 3
8132 Rev. B



Engine Assembly Parts List

Item	Part Number	Description	Qty	Item	Part Number	Description	Qty
1	000-052-906	Adapter, 1/4" F X 12mm Male	1	34	- - -	Hose, Coolant (Comes w/ Engine)	1
2	000-004-012	Alternator (Comes w/ Engine)	1	35	000-068-500	Hose, Formed - Upper Radiator Engine	2
3	610-013-576	Assembly, Exhaust	1	36	000-068-221	Hose, Oil Drain	1
4	610-004-576	Assembly, Flywheel Plate	1	37	000-068-941	Hose, 1" Id Coolant Mod. 9" X 3"	1
5	000-010-131	Belt, 3vx450 Super HC	3	38	000-052-293	Insert, #23 (1/8" NPT X 3/16" Barb)	1
6	000-010-133	Belt, Alternator (Comes w/ Engine)	1	39	000-052-109	Insert, #F24	1
7	000-015-1032	Bracket, Engine, Coil Relocation	2	40	000-077-010	Key, 1/4" X 1-1/2" Lg. Class 2 Fit	2
8	000-015-1052	Bracket, Engine, Front - Coated	2	41	000-052-821	Mender, 1" X 1" Hose	3
9	000-015-265	Bracket, Machine Tie Down	2	42	000-106-001	Plug, 1/8" NPT	1
10	000-015-1167	Bracket, Starter Cooling Hose	1	43	000-106-174	Plug, Spark (Comes w/ Engine)	3
11	000-020-055	Bushing, HQ 1-1/8	1	44	000-108-165	Protector, Starter	1
12	000-020-070	Bushing, QD SDS Style	1	45	000-109-040	Pulley, Ak47-H	1
13	000-029-035	Carburetor (Comes w/ Engine)	1	46	000-109-124	Pulley, Ø6.5" O.D. Tri-3vx Section	1
14	000-169-234	Carburetor Solenoid (Comes w/ Engine)	1	47	000-111-192	Pump, Water (Comes w/ Engine)	1
15	000-033-020	Clamp, Size #16 Hose	11	48	000-113-012	Radiator, Kubota (Comes w/ Engine)	1
16	000-033-003	Clamp, Size #4 Mini Hose	1	49	000-143-017	Screw, 3/8"-16unc X 0.75" Lg. Hex Head Grd. 8	4
17	000-033-060	Clamp, Size #80 Hose	1	50	000-143-077	Screw, 6mm X 20mm Lg. Socket Head	1
18	000-072-019	Coil, Ignition (Comes w/ Engine)	1	51	000-143-185	Screw, 8mm X 20mm Gr. 8.8 Hex Head	2
19	000-047-042	Engine, Kubota 32.5 HP	1	52	000-143-710	Screw, M10 X 1.5 X 30mm Lg.	8
20	000-049-256	Filter, Oil (Comes w/ Engine)	1	53	000-149-545	Sensor, 240°F N/C	1
21	000-057-231	Gasket, Exhaust Manifold (Comes w/ Engine)	1	54	000-149-144	Sensor, Crank Position	1
22	000-057-232	Gasket, Exhaust Outlet Flange (Comes w/ Engine)	1	55	- - -	Shaft, Stub - Kubota (Comes w/ Engine)	1
23	000-057-230	Gasket, Oil Pan (Comes w/ Engine)	1	56	000-091-048	Starter (Comes w/ Engine)	1
24	000-057-229	Gasket, Valve Cover (Comes w/ Engine)	1	57	000-052-155	Tee, 3/16" Plastic Vacuum Insert	2
25	000-068-250	Hose, 1" I.D. Green Stripe - Bulk	1	58	000-149-567	Thermostat (Comes w/ Engine)	1
26	000-068-924	Hose, 1" I.D. Silicone Flexible	1	59	000-169-156	Valve, Check - Diverter Control	2
27	000-068-016	Hose, 5/16" I.D. Rubber - Bulk	1	60	000-174-003	Washer, 1/4" Flat	1
28	000-068-030	Hose, 5/32" I.D. Vacuum - Bulk	1	61	000-174-005	Washer, 3/8" Flat	4
29	000-068-030	Hose, 5/32" I.D. Vacuum - Bulk	1	62	000-174-021	Washer, 3/8" Lock	4
30	000-068-030	Hose, 5/32" I.D. Vacuum - Bulk	1	63	000-174-004	Washer, 5/16" Flat	2
31	000-068-030	Hose, 5/32" I.D. Vacuum - Bulk	1	64	000-174-018	Washer, 5/16" S/S Lock	2
32	000-068-030	Hose, 5/32" I.D. Vacuum - Bulk	1	65	- - -	Washer, Flat (Comes With Engine)	8
33	000-068-030	Hose, 5/32" I.D. Vacuum - Bulk	1				

TITAN 575

Figure 9-13. Exhaust Assembly
8133

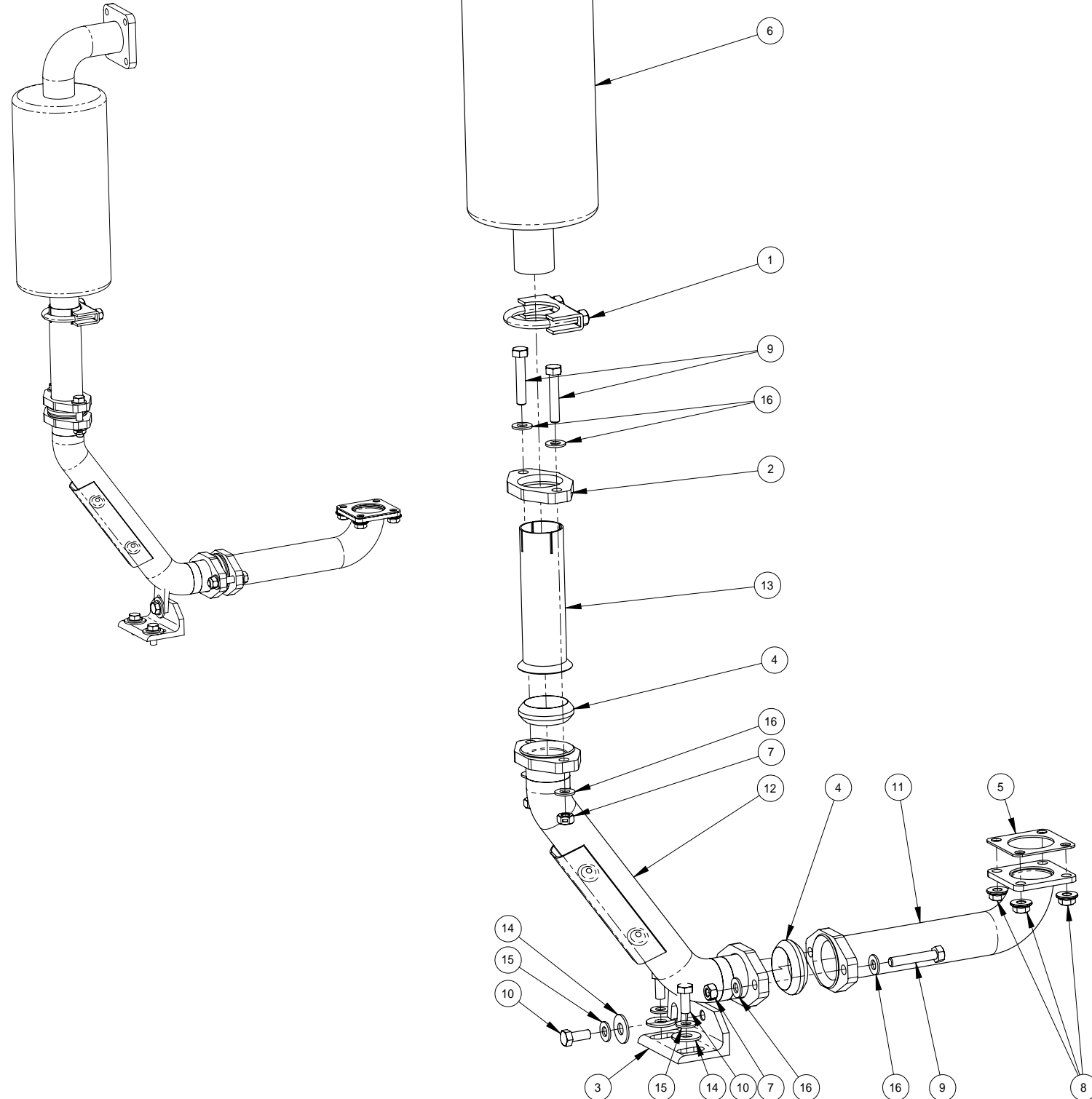

Exhaust Assembly Parts List

Item	Part Number	Description	Qty
1	000-033-068	Clamp, 1-1/2" Exhaust	1
2	000-105-181	Flange, Ø1.50" Exhaust Donut	1
3	000-015-393	Foot, Muffler Support	1
4	000-057-199	Gasket, Exhaust Donut	2
5	000-057-146	Gasket, Four Hole Exhaust Diverter	1
6	000-093-158	Muffler/Catalytic	1
7	000-094-081	Nut, 5/16"-18UNC Hex 2-Way Locking	4
8	000-094-078	Nut, 5/16-18UNC Hex Flange	4
9	000-143-124	Screw, 5/16"-18UNC X 1.75" Lg. Hex Head	4
10	000-143-012	Screw, 5/16"-18UNC X 0.75" Lg.	3
11	000-125-252	Tube, Exhaust Diverter - Welded	1
12	000-125-856	Tube, Lower Engine Exhaust - Weldment	1
13	000-125-855	Tube, Ø1.50" O.D. X 0.049" Wall X 5" Lg. Flare	1
14	000-174-005	Washer, 3/8" Flat	3
15	000-174-004	Washer, 5/16" Flat	3
16	000-174-049	Washer, 5/16" Flat	8

Figure 9-14. Top Cover Assembly
8134

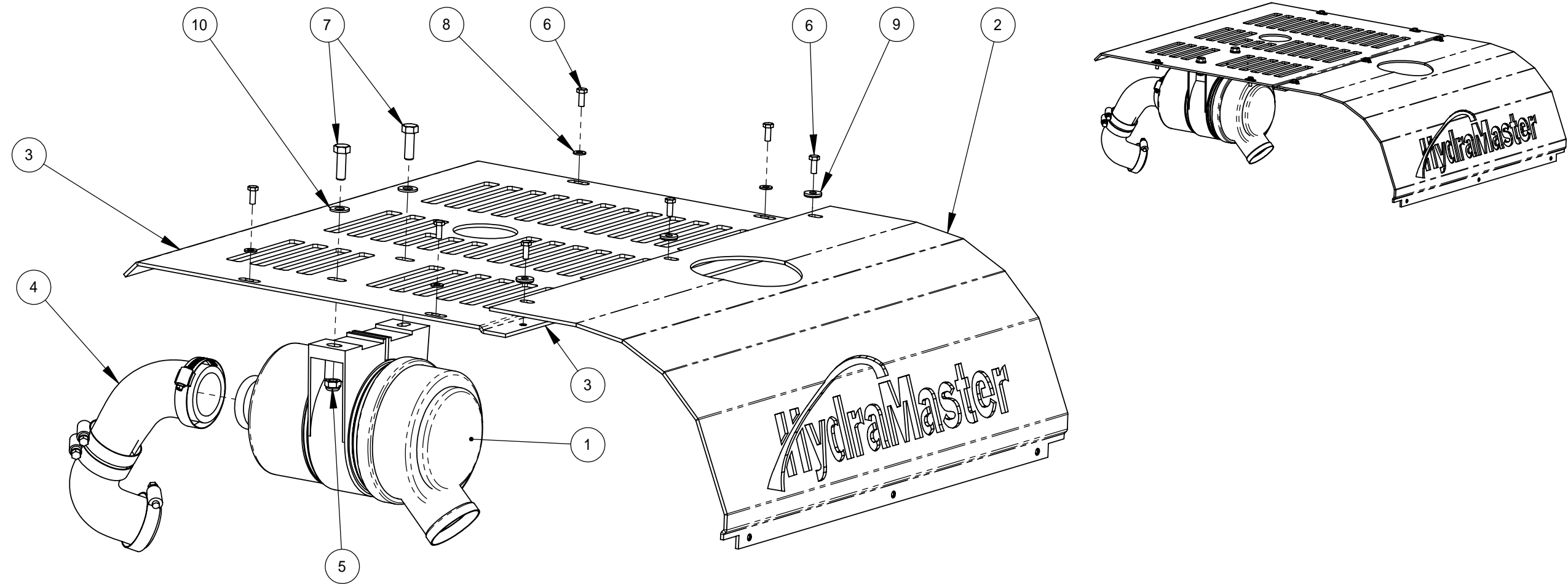

Top Cover Assembly Parts List

Item	Part Number	Description	Qty
1	- - -	Air Cleaner - Engine (Comes w/ Engine)	1
2	000-041-552	Cover, Brow - Machine - Coated	1
3	000-041-554	Cover, Top - Machine - Coated	1
4	000-068-916	Hose, Kubota Air Intake - Modified	1
5	000-094-038	Nut, 5/16"-18UNC Nylock	2
6	000-143-126	Screw, #10-24UNC X 0.50" Lg. Hex Head	7

Item	Part Number	Description	Qty
7	000-143-143	Screw, 5/16"-18UNC X 1.00" Lg. Hex Head	2
8	000-174-001	Washer, #10 Flat	4
9	000-174-060	Washer, 1/4" Rubber-Backed	3
10	000-174-049	Washer, 5/16" Flat	2

TITAN 575

Figure 9-15. Flywheel Plate Assembly
8135 Rev. B

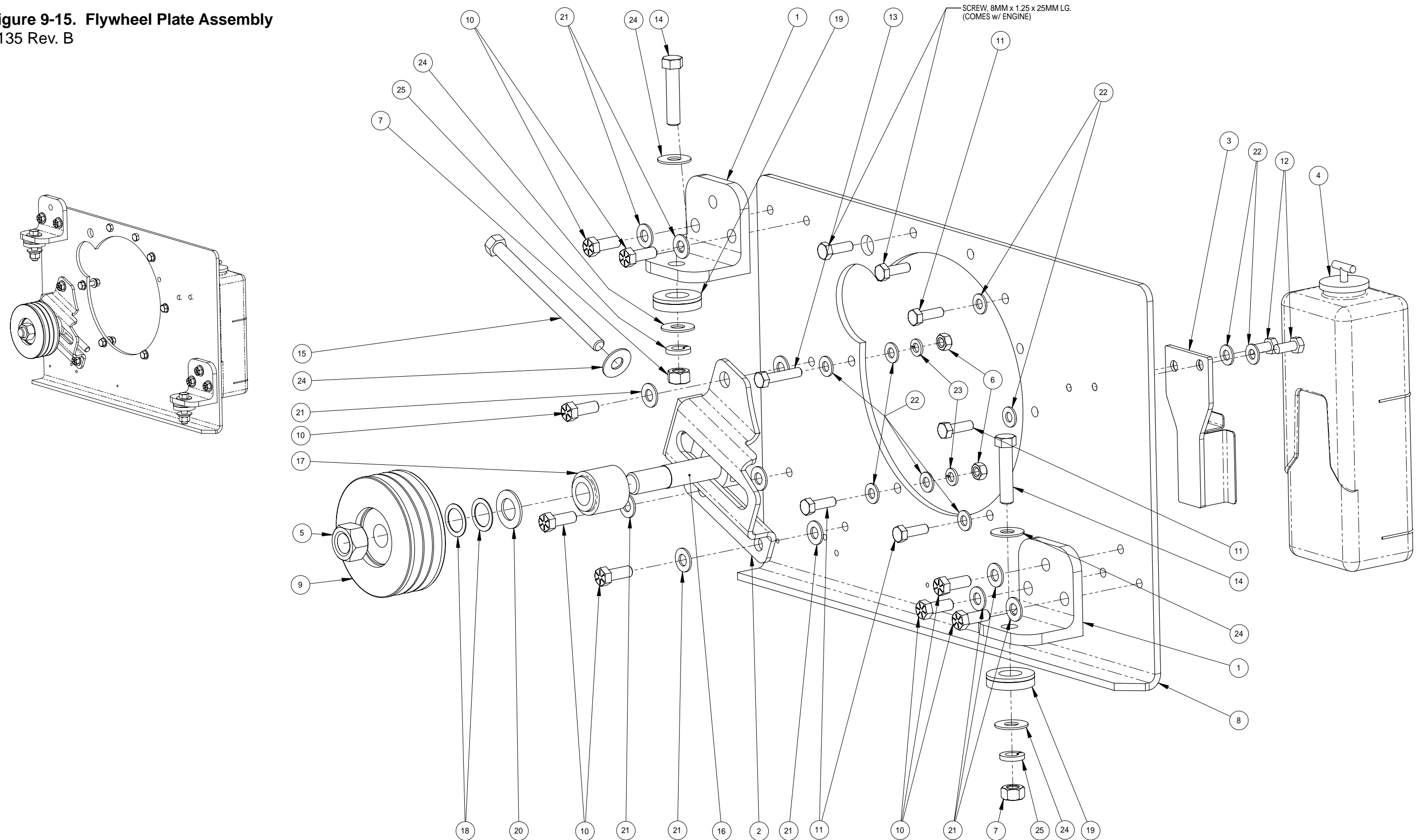

Flywheel Plate Assembly Parts List

Item	Part Number	Description	Qty
1	000-015-1164	Bracket, Angle - Rear Engine Mount - Coated	2
2	000-015-941	Bracket, Idler Pulley Tensioner	1
3	- - -	Bracket, Overflow Jug Mounting (Comes w/ Engine)	1
4	- - -	Jug, Overflow (Comes w/ Engine)	1
5	000-094-105	Nut, 3/4"-16UNF Hex Zinc Plated	1
6	000-094-120	Nut, 5/16"-18UNC Hex Z/P	5
7	000-094-018	Nut, 7/16"-14UNC Hex Z/P	2
8	000-105-586	Plate, Flywheel, Kubota	1
9	000-109-125	Pulley, Tri Groove 3vx	1
10	000-143-018	Screw, 3/8"-16UNC X 1" Hex Head - Grade 8	8
11	000-143-013	Screw, 5/16"-18UNC X 1.00" Lg. Grade 8	4
12	000-143-012	Screw, 5/16"-18UNC X 0.75" Lg.	2
13	000-143-015	Screw, 5/16-18 X 1 1/2" HHC	1

Item	Part Number	Description	Qty
14	000-143-587	Screw, 7/16"-14UNC X 2" Lg. Hex Head	2
15	000-143-554	Screw, 7/16-14 UNC. X 6.5" Lg. Ft Gr. 5	1
16	000-150-011	Shaft, Idler Dual V Belt	1
17	000-154-195	Spacer, Idler Pulley - 1.403" Lg.	1
18	000-174-177	Washer, 0.813 I.D. X 1.125 O.D. X 0.0299 Thk.	2
19	000-174-105	Washer, 1-1/16" I.D. Self Aligning Spherical 2 Pc Set	2
20	000-174-027	Washer, 3/4" Flat - Brass	1
21	000-174-005	Washer, 3/8" Flat	11
22	000-174-004	Washer, 5/16" Flat	12
23	000-174-018	Washer, 5/16" S/S Lock	5
24	000-174-006	Washer, 7/16" Flat	5
25	000-174-022	Washer, 7/16" Lock	2

TITAN 575

Figure 9-16. Upper Dash Assembly
8261

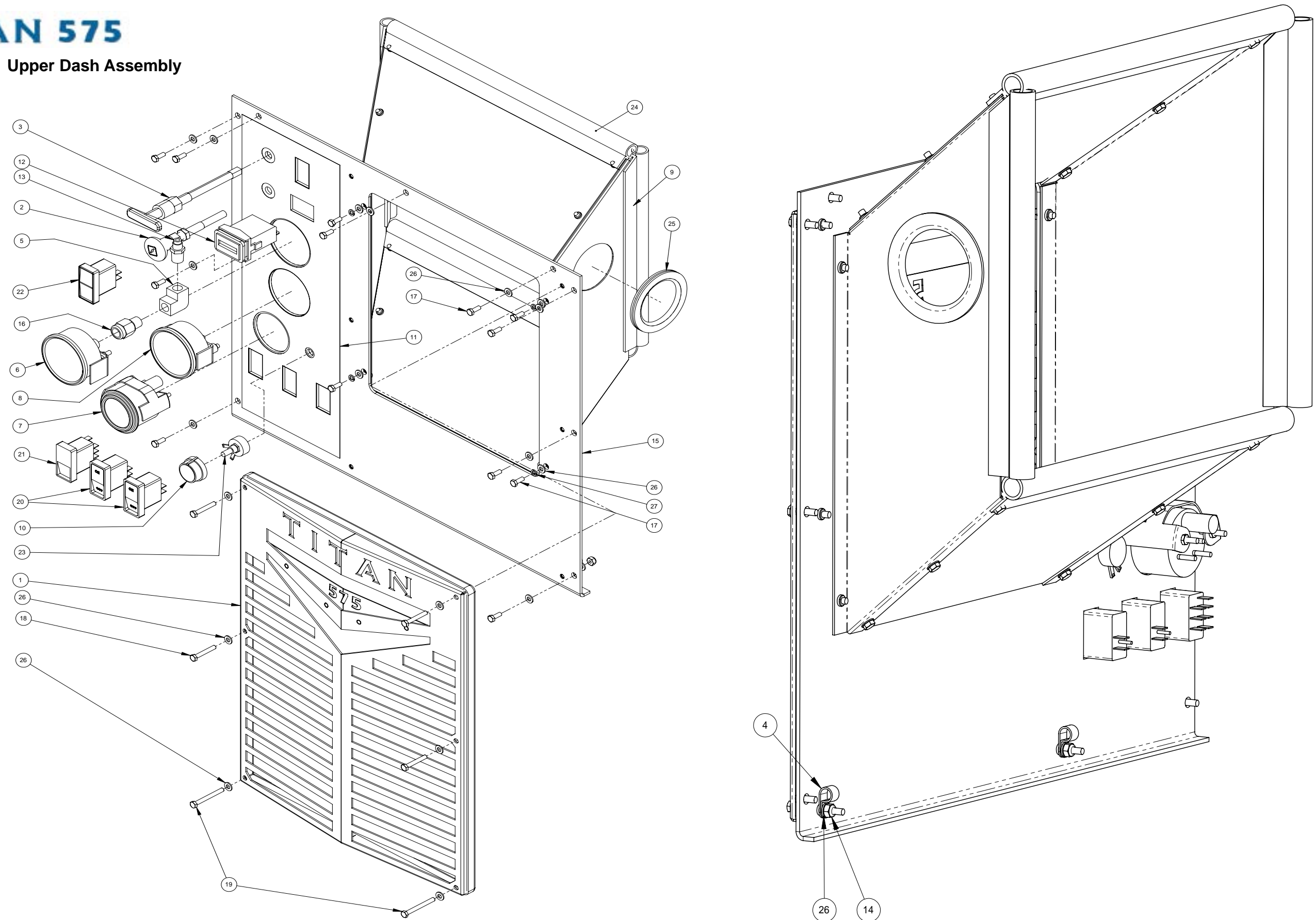

Upper Dash Assembly Parts List

Item	Part Number	Description	Qty
1	- - -	Assembly, Grill	1
2	000-025-003	Cable, Choke with Detent	1
3	000-025-020	Cable, Throttle Locking	1
4	000-033-128	Clamp, 3/8" Nylon Hose	2
5	000-052-088	Elbow, 1/4" FPT X FPT	1
6	000-074-007	Gauge, Pressure 0 -1,500 psi, UPC #401406.	1
7	000-074-016	Gauge, Temperature	1
8	000-074-017	Gauge, 0-30" Hg Vac. 2 1/2" HydraMaster Face	1
9	000-042-076	Housing, Radiator Shroud	1
10	000-061-056	Knob, Temperature Adjustment	1
11	000-081-369	Label, Upper Dash - Kubota	1
12	000-074-170	Meter, Rectangular Hour w/o Bezel	1
13	000-052-527	Nipple, 1/4" SAE X 1/4" NPT	1
14	000-094-034	Nut, #10-24UNC Nylock	2

Item	Part Number	Description	Qty
15	000-100-203	Panel, Upper Dash - Coated	1
16	000-135-052	Regulator, Hi PSI Snubber	1
17	000-143-126	Screw, #10-24UNC X 0.50" Lg. Hex Head	13
18	000-143-171	Screw, #10-24UNC X 1.25" Lg. Hex Head	4
19	000-143-065	Screw, #10-24UNC X 1.75" Lg. Hex Head	2
20	000-157-040	Switch, 20 Amp Rocker	2
21	000-157-131	Switch, 3-Way Speed Control	1
22	000-157-152	Switch, Ignition	1
23	000-149-560	Thermostat, Potentiometer *	1
24	000-131-060	Trimlok, 3/4" Bulb X 3/16" Opening	1
25	000-131-131	Trimlok, 3/8 X 1/8 Rubber	1
26	000-174-001	Washer, #10 Flat	21
27	000-174-014	Washer, #10 Lock	4

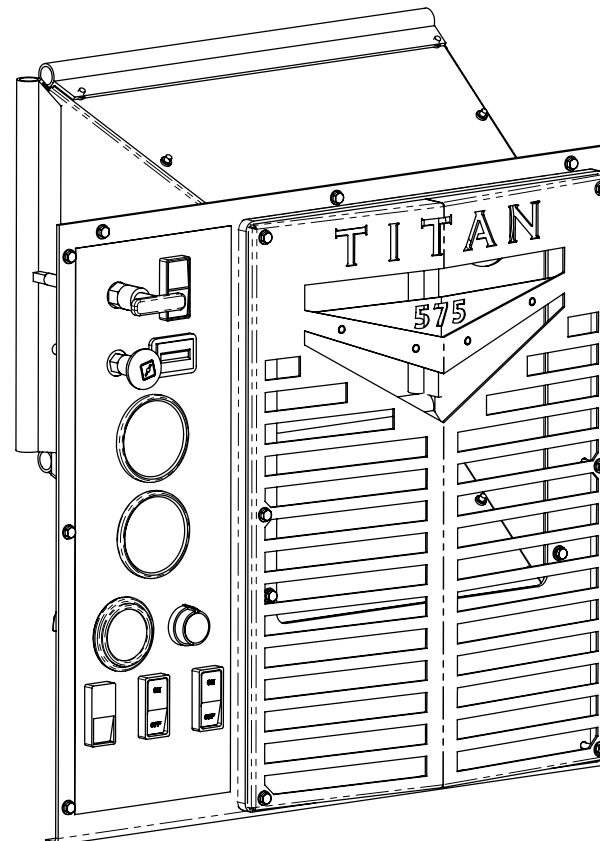

NOTICE

* To order a spare thermostat (P/N 000-149-560), specify P/N 000-149-561.

TITAN 575

Figure 9-17. Electrical Panel Assembly - View 1 of 2
7438 Rev. C

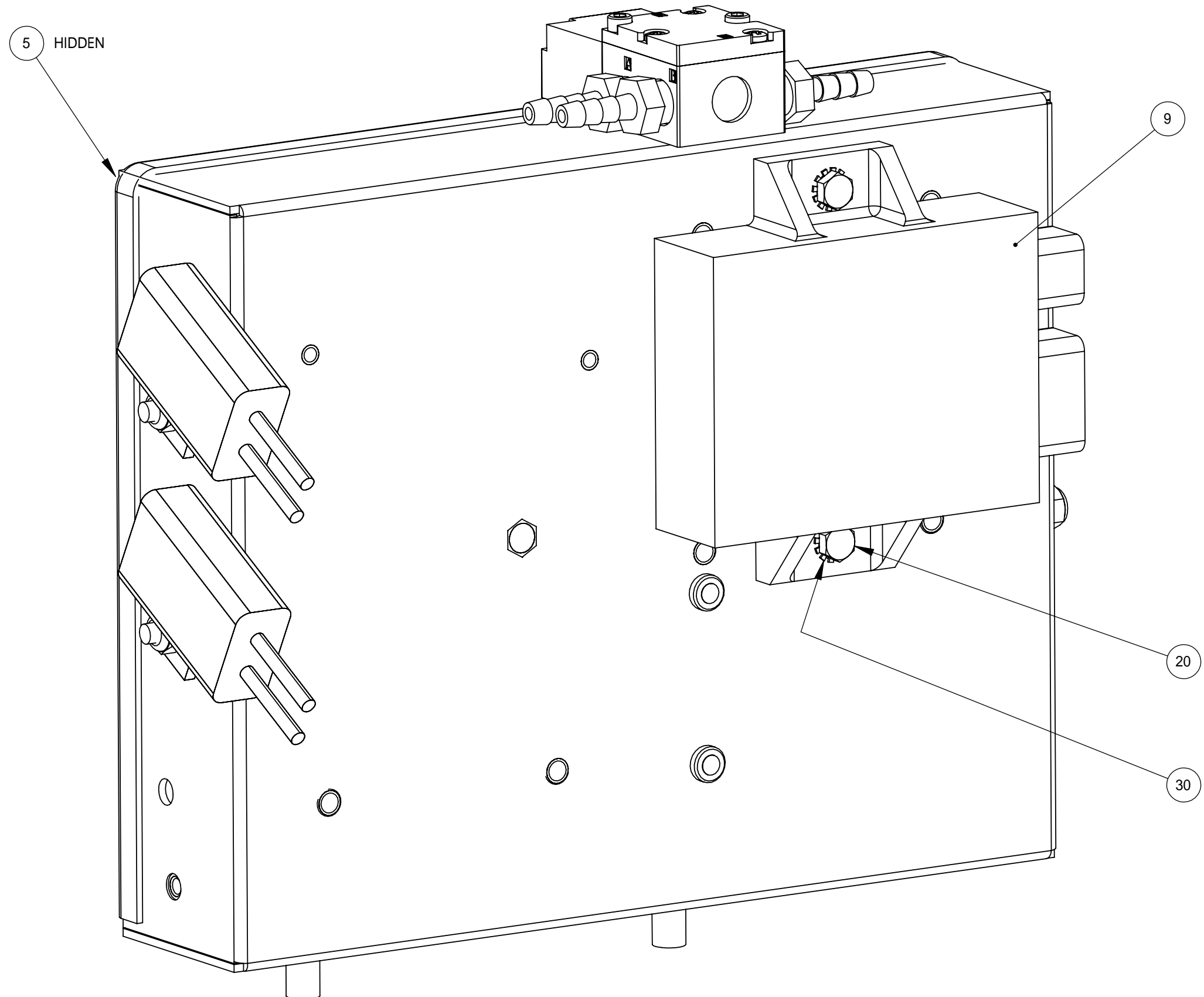
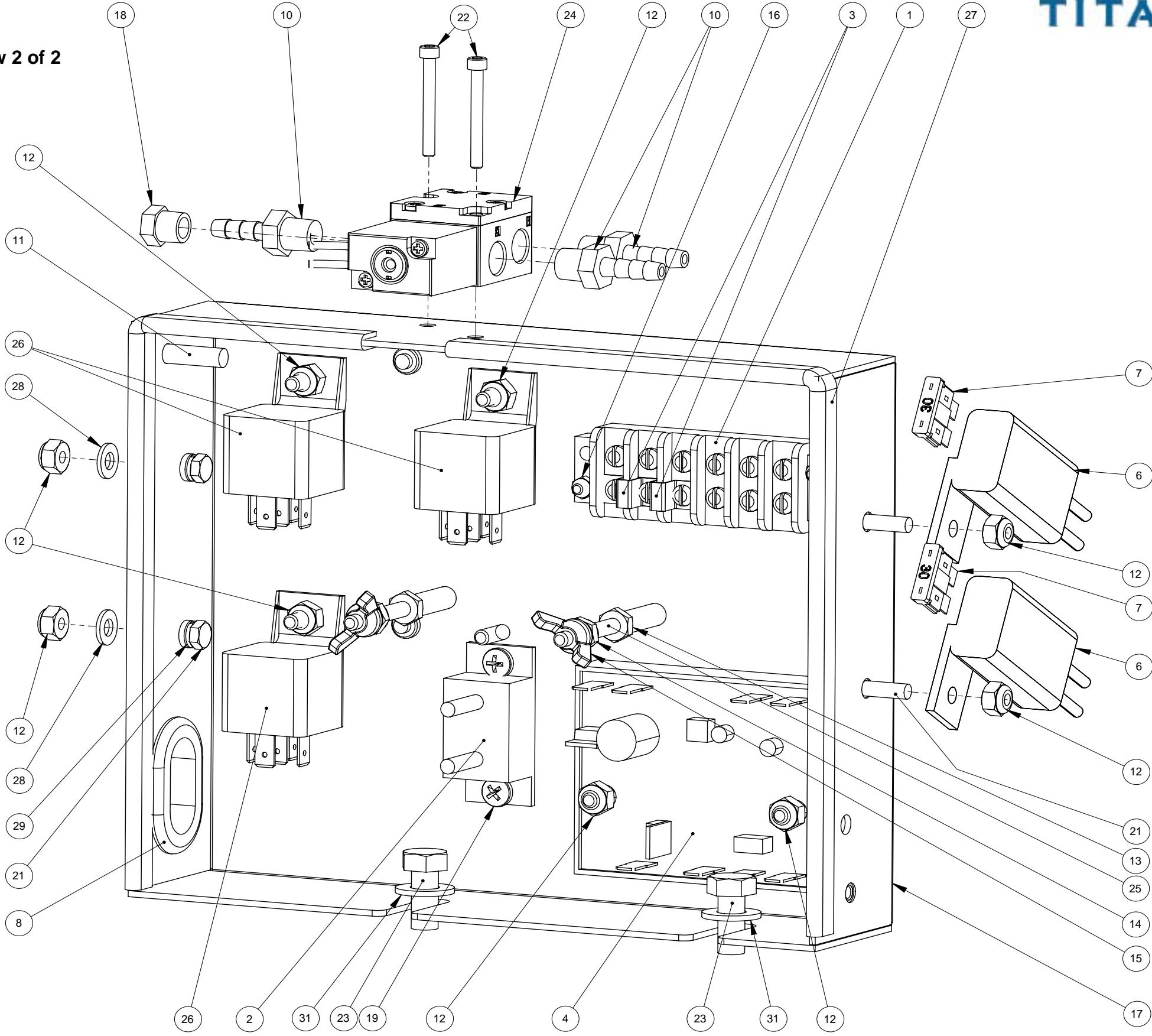

Figure 9-18. Electrical Panel Assembly - View 2 of 2
7438 Rev. C



TITAN 575

Electrical Panel Assembly Parts List

Item	Part Number	Description	Qty
1	000-012-002	Block, 6-Post Terminal	1
2	000-018-040	Circuit Breaker, 50 Amp	1
3	000-037-011	Connector, "Jumper" Terminal Block	2
4	000-074-125	Controller, Temp Single Analog Input - RTD	1
5	000-041-478	Cover, Electrical Panel	1
6	000-056-006	Fuse Holder, In-Line - Weatherproof	2
7	000-056-011	Fuse, 30 Amp	2
8	000-060-014	Grommet, 1.00" I.D. X 1.50" O.D.	1
9	000-072-018	Ignition Processor, Kubota Wg972	1
10	000-052-293	Insert, #23 (1/8" NPT X 3/16" Barb)	3
11	000-084-010	Light, Green LED Indicator Mini	1
12	000-094-034	Nut, #10-24UNC Nylock	9
13	000-094-003	Nut, #10-32UNF Hex	2
14	000-094-058	Nut, #10-32UNF Nylock	2
15	000-094-108	Nut, #10-32UNF Wing	2
16	000-094-063	Nut, #6-32UNC Nylock	2
17	000-100-182	Panel, Electrical - Universal	1

Item	Part Number	Description	Qty
18	000-106-014	Plug, Vent	1
19	000-143-533	Screw, #10-24UNC X 0.25" Lg. Pan Head Phillips	2
20	000-143-126	Screw, #10-24UNC X 0.50" Lg. Hex Head	2
21	000-143-132	Screw, #10-24UNC X 0.75" Lg. Hex Head	4
22	000-143-700	Screw, #6-32UNC X 1.25" Lg. Socket Head	2
23	000-143-012	Screw, 5/16"-18UNC X 0.75" Lg.	2
24	000-169-226	Solenoid, Air Actuator 4- Way Valve	1
25	000-156-030	Stud, #10-32UNF X 2" Lg. S/S	2
26	000-157-022	Switch, Relay	3
27	000-131-131	Trimlok, 3/8" X 1/8"	1
28	000-174-001	Washer, #10 Flat	2
29	000-174-014	Washer, #10 Lock	4
30	000-174-015	Washer, #10 Outside Star	2
31	000-174-049	Washer, 5/16" Flat	2

Figure 9-19. Blower Assembly
7433 Rev. C

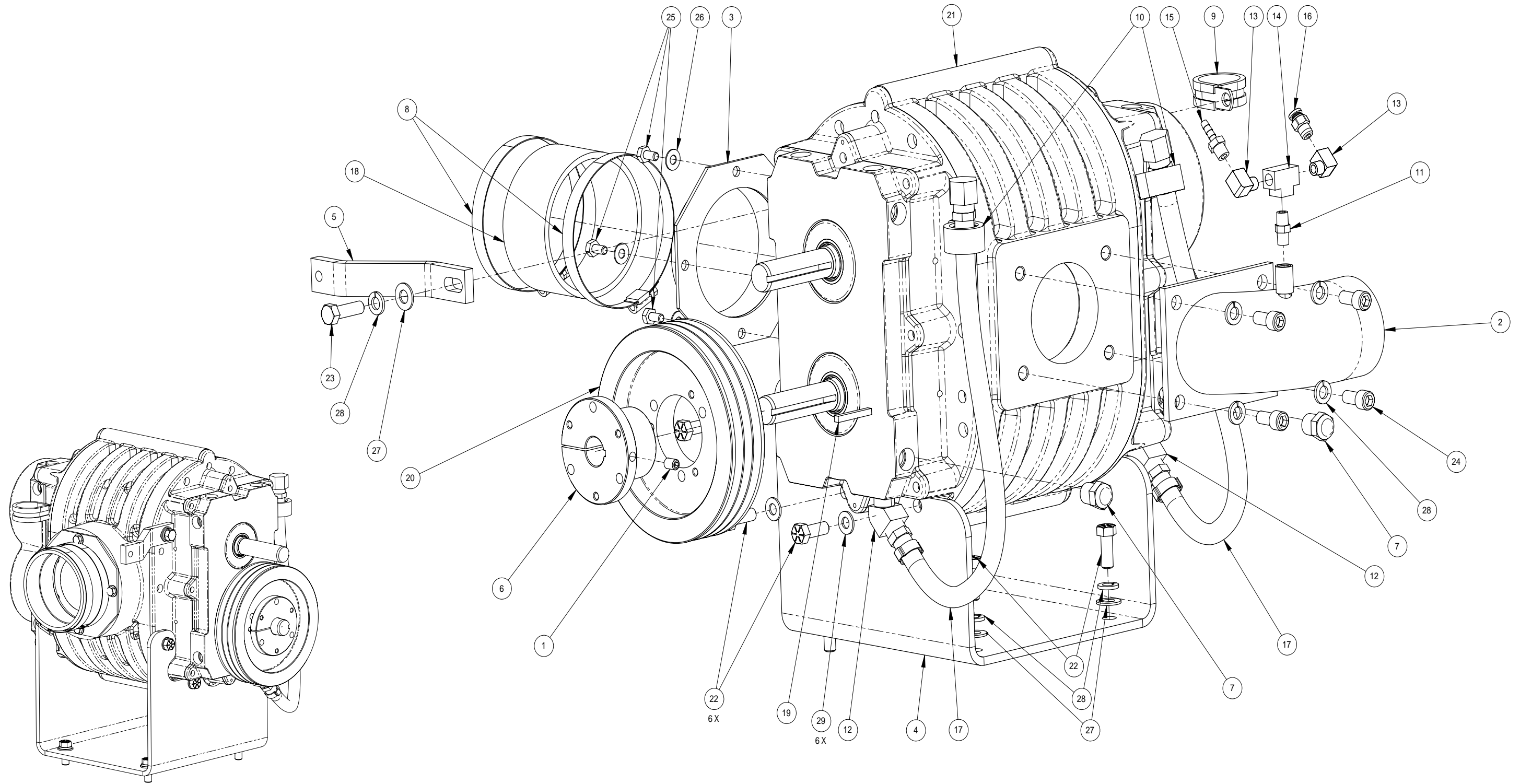

TITAN 575

Blower Assembly Parts List

Item	Part Number	Description	Qty
1	- - -	Set Screw (Comes w/Bushing)	1
2	000-001-041	Adapter, Blower Inlet	1
3	000-001-172	Adapter, Blower Outlet	1
4	000-015-976	Bracket, Blower Mounting	1
5	000-015-988	Bracket, Blower to Silencer Support	1
6	000-020-071	Bushing, QD SDS Style	1
7	000-027-112	Cap, Oil Sight Glass Tuthill Blower (Comes w/ Blower)	2
8	000-033-015	Clamp, 4" Hose	2
9	000-033-116	Clamp, 1-1/2" Cushion Loop w/ 7/16" Mounting Hole	1
10	000-033-117	Clamp, 1" Cushion Loop w/ 7/16 Mount Hole	2
11	000-052-069	Nipple, 1/8" NPT Hex	1
12	000-052-083	Elbow, 3/8" NPT Street X 45°	2
13	000-052-084	Elbow, 1/8" NPT Street	2
14	000-052-092	Tee, 1/8" FPT	1
15	000-052-293	Insert, #23 (1/8" NPT X 3/16" Barb)	1

Item	Part Number	Description	Qty
16	000-052-814	Nipple, 1/8" NPT X 1/4" Pressto Lock	1
17	000-068-219	Hose, Pump Drain	2
18	000-068-778	Hose, Ø4.0" I.D. X 2" Lg.	1
19	000-077-011	Key, 3/16" X 1 1/2" Long	1
20	000-109-124	Pulley, Ø6.5" O.D. Tri-3vx Section	1
21	000-111-147	Blower, 4007 Dominator	1
22	000-143-018	Screw, 3/8"-16UNC X 1" Hex Head - Grade 8	10
23	000-143-025	Screw, 3/8"-16UNC. X 1.25" Lg. Hex Head Gr. 8	1
24	000-143-094-1	Screw, 3/8"-16UNC X 3/4" Lg. Socket Head	4
25	000-143-333	Screw, 1/4"-20UNC X 0.50" Lg. Hex Head	3
26	000-174-003	Washer, 1/4" Flat	3
27	000-174-005	Washer, 3/8" Flat	5
28	000-174-021	Washer, 3/8" Lock	9
29	000-174-049	Washer, 5/16" Flat	6

Figure 9-20. Pump and Silencer Assembly
7445 Rev. A

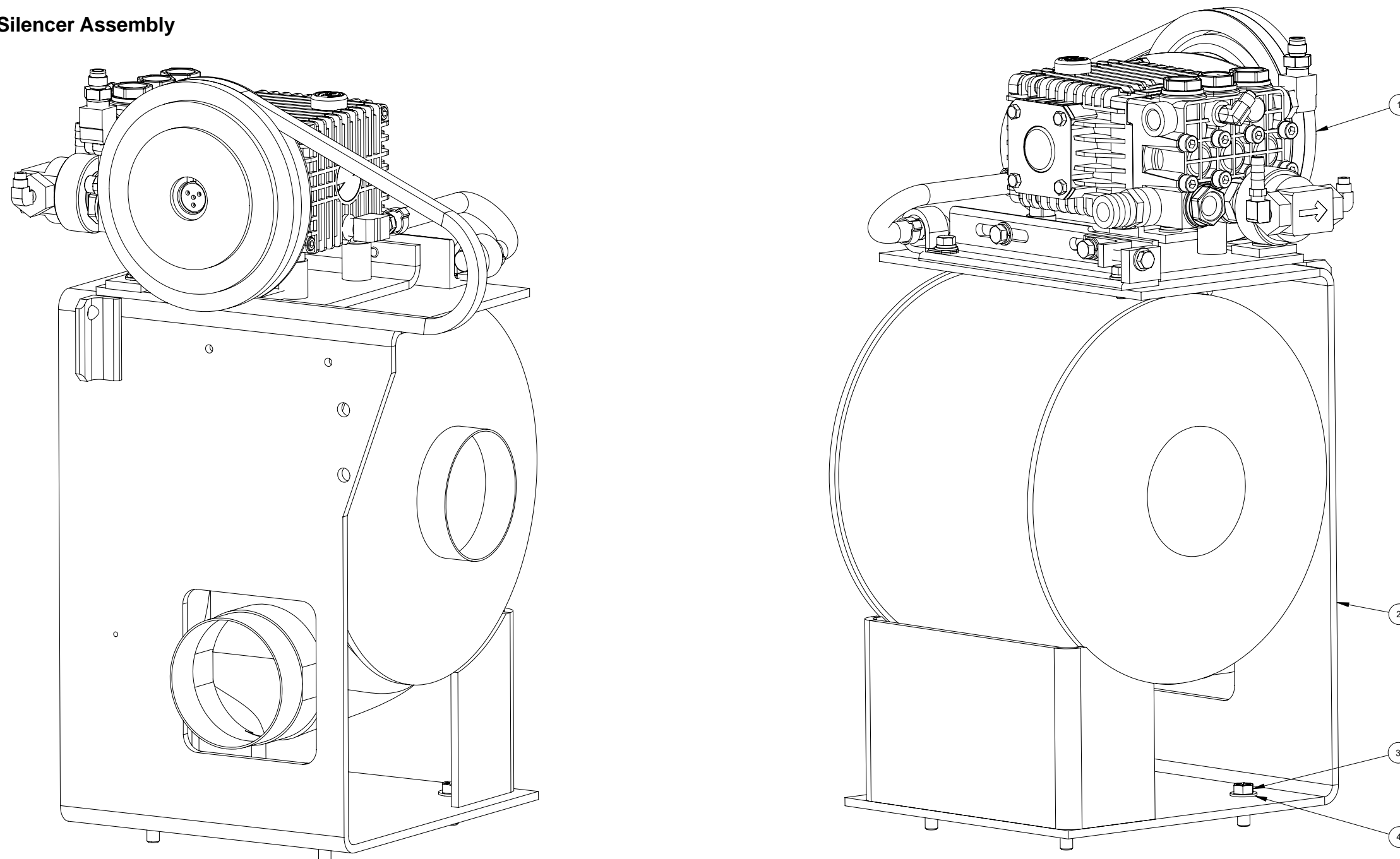

Pump and Silencer Assembly Parts List

Item	Part Number	Description	Qty
1	---	Assembly, Pump	1
2	000-093-105	Silencer, 4' Slip Connection - Weldment	1
3	000-143-018	Screw, 3/8-16UNC X 1" Hex Head - Grade 8	4
4	000-174-005	Washer, 3/8" Flat	4

TITAN 575

Figure 9-21. Pump Assembly - View 1 of 2
7434 Rev. A

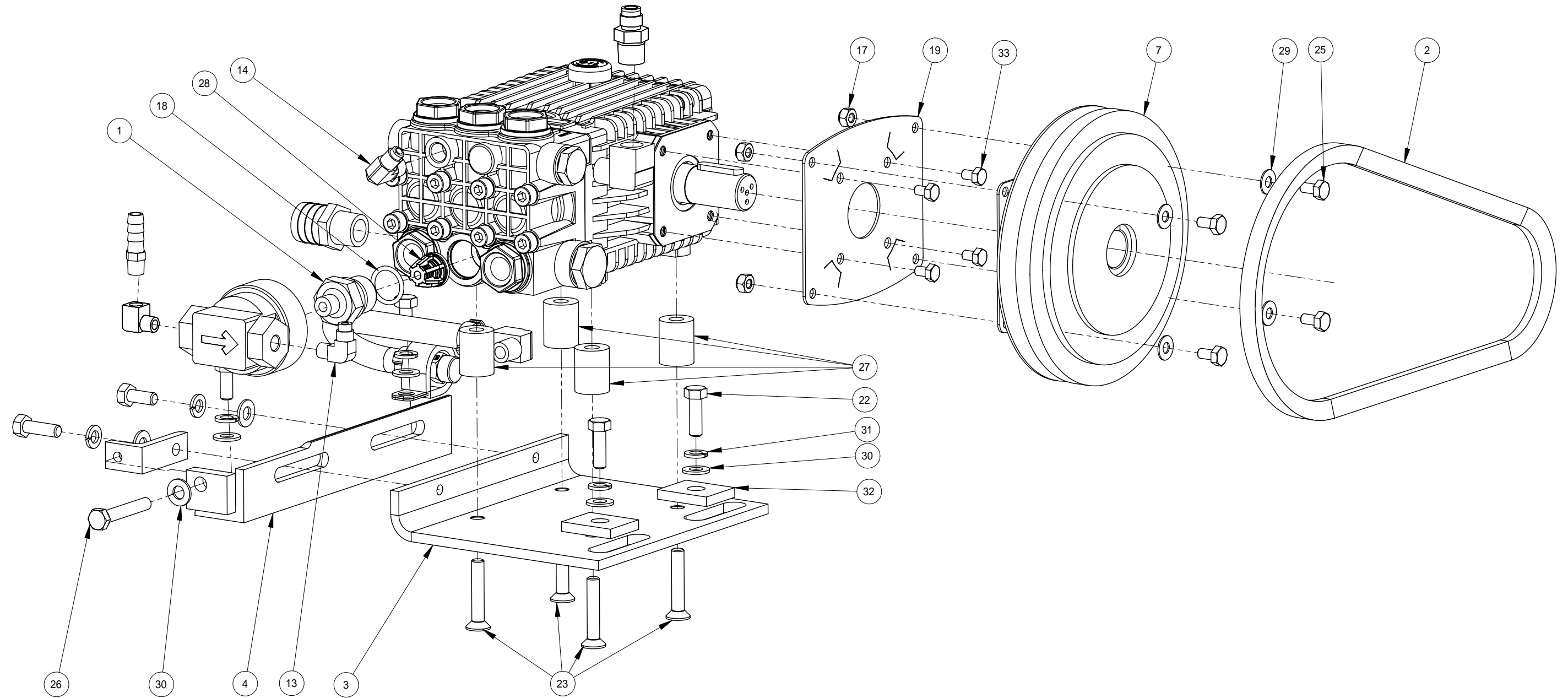
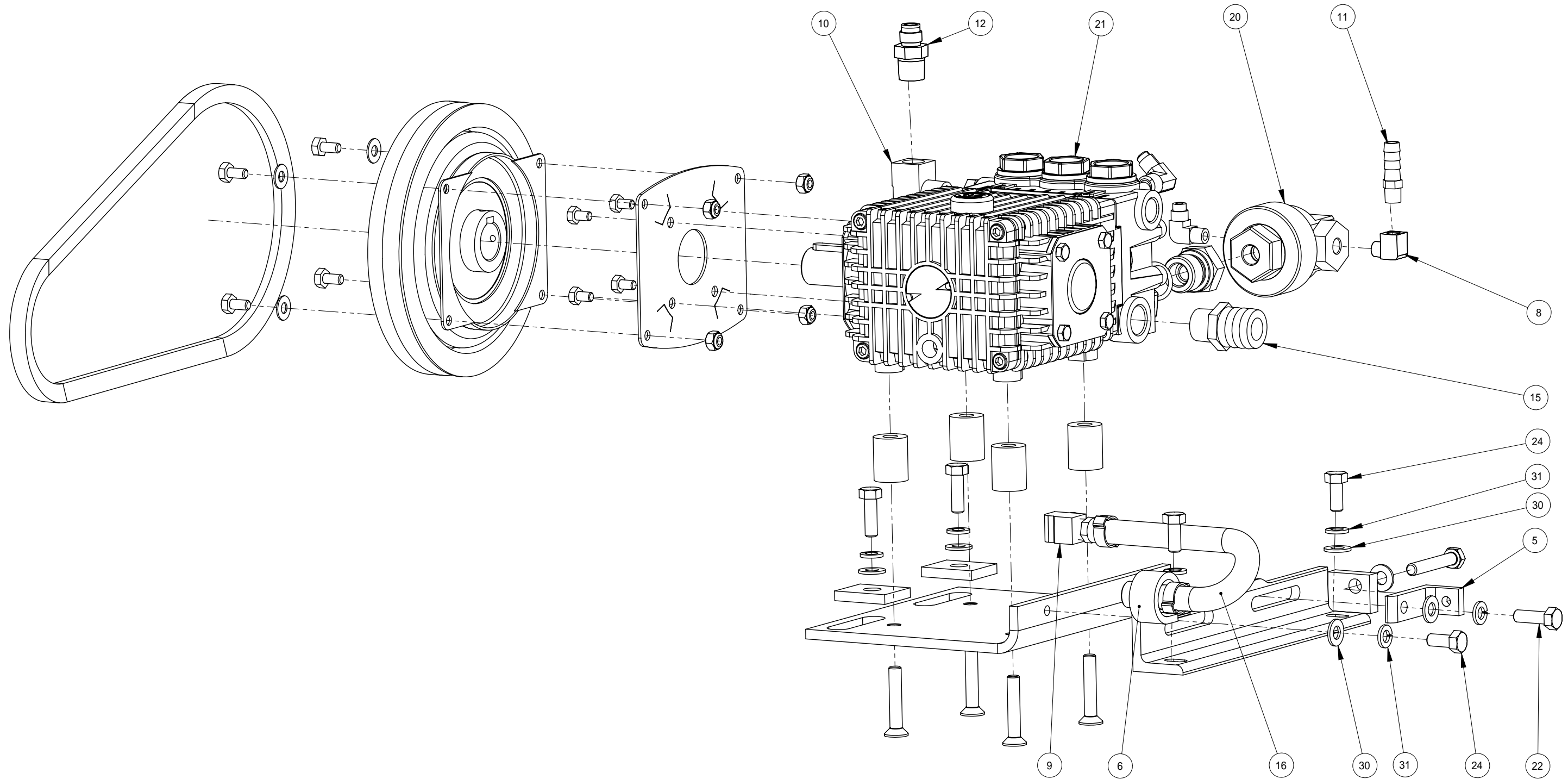

Figure 9-22. Pump Assembly - View 2 of 2
7434 Rev. A



TITAN 575

Pump Assembly Parts List

Item	Part Number	Description	Qty
1	000-001-154	Adapter, GP to Chemical Pump S/S 4.0 Gallon	1
2	000-010-128	Belt, HD9330 Green Back	1
3	000-015-990	Bracket, Pump Mount	1
4	000-015-991	Bracket, Pump Mount Guide - Weldment	1
5	000-015-998	Bracket, Pump Tensioning	1
6	000-033-117	Clamp, 1" Cushion Loop w/7/16 Mount Hole	1
7	000-036-008	Clutch, 7" O.D. 24 mm Single Groove	1
8	000-052-084	Elbow, 1/8" NPT Street	1
9	000-052-085	Elbow, 1/4" NPT Street	1
10	000-052-086	Elbow, 3/8" NPT Street	1
11	000-052-099	Insert, #26 (1/8" NPT X 3/8" Barb)	1
12	000-052-528	Nipple, 3/8" M JIC X 3/8" NPT	1
13	000-052-531	Elbow, 1/8" NPT X 1/4" SAE	1
14	000-052-532	Elbow, 1/4" SAE X 1/4" NPT	1
15	000-052-753	Insert, #816 (1/2" NPT X 1" Barb)	1
16	000-068-794	Hose, 3/8" X 17" Lg. Pump Drain	1
17	000-094-071	Nut, 1/4"-20UNC Nylock	4

Item	Part Number	Description	Qty
18	000-097-057	O-Ring, Adapter - Chemical Pump	1
19	000-105-550	Plate, Pump Clutch - GP 4.0 gpm	1
20	000-111-184	Pump, GP Chemical	1
21	000-111-188	Pump, 4.0 gpm GP	1
22	000-143-013	Screw, 5/16"-18UNC X 1.00" Lg. Grade 8	3
23	000-143-084	Screw, 8 mm X 1.25 X 45 mm Lg. Flat Head Hex Drive	4
24	000-143-242	Screw, 5/16"-18UNC X 0.75" Lg. Hex Head Grade 5	3
25	000-143-333	Screw, 1/4"-20UNC X 0.50" Lg. Hex Head	4
26	000-143-585	Screw, 5/16"-18UNC X 2" Lg. Hex Head	1
27	000-154-184	Spacer, 3/8" I.D. X 1.125" Lg. X 7/8" O.D.	4
28	000-169-221	Valve, GP Pump Check - Mod. - 4.0 Gallon	1
29	000-174-003	Washer, 1/4" Flat	4
30	000-174-004	Washer, 5/16" Flat	7
31	000-174-018	Washer, 5/16" S/S Lock	6
32	000-174-068	Washer, Blower Feet	2
33	000-143-608	Screw, 6 mm X 10 mm Lg. Z/P	4

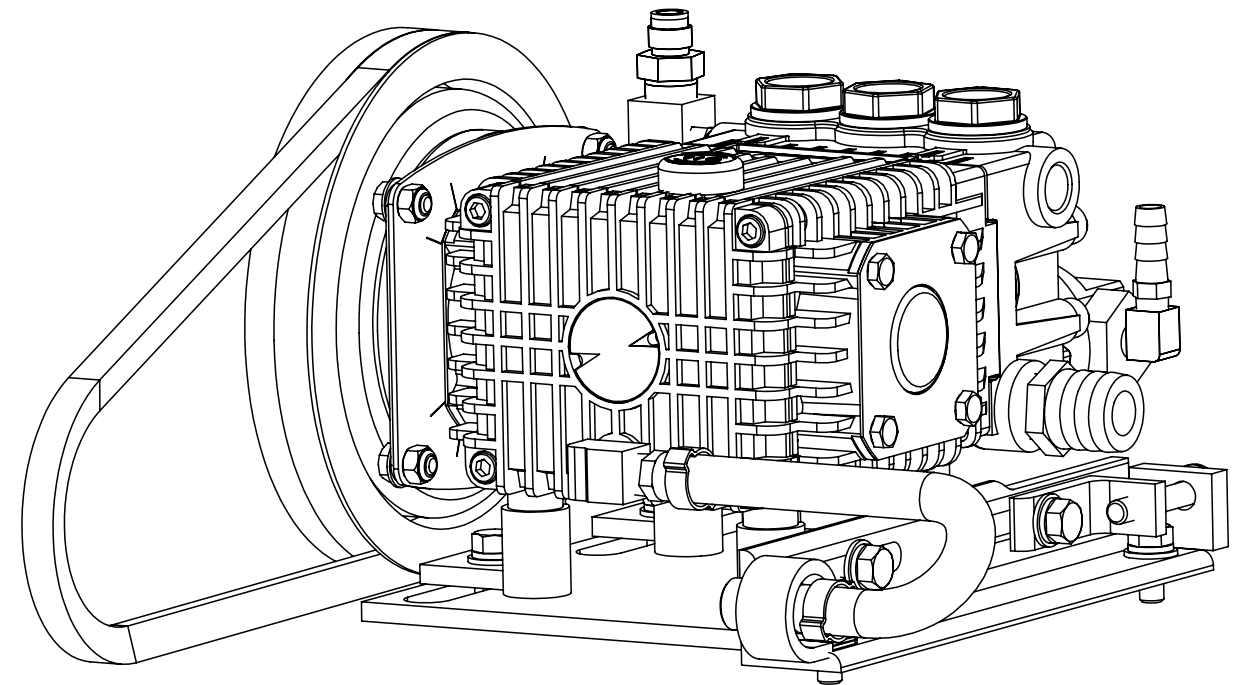
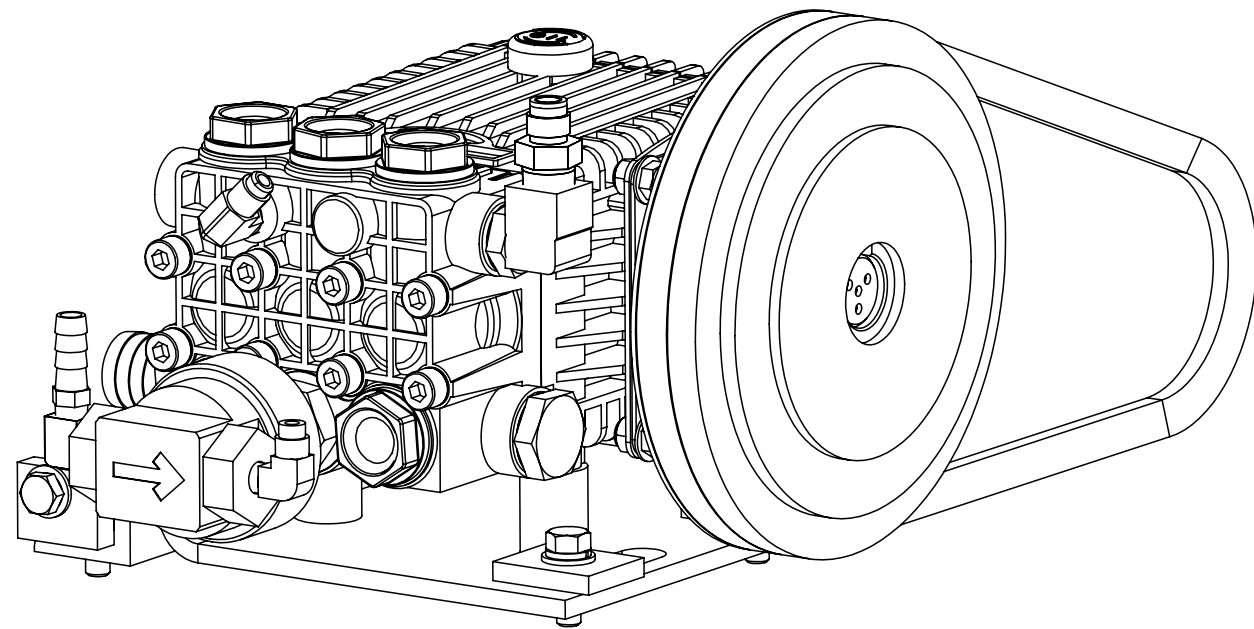
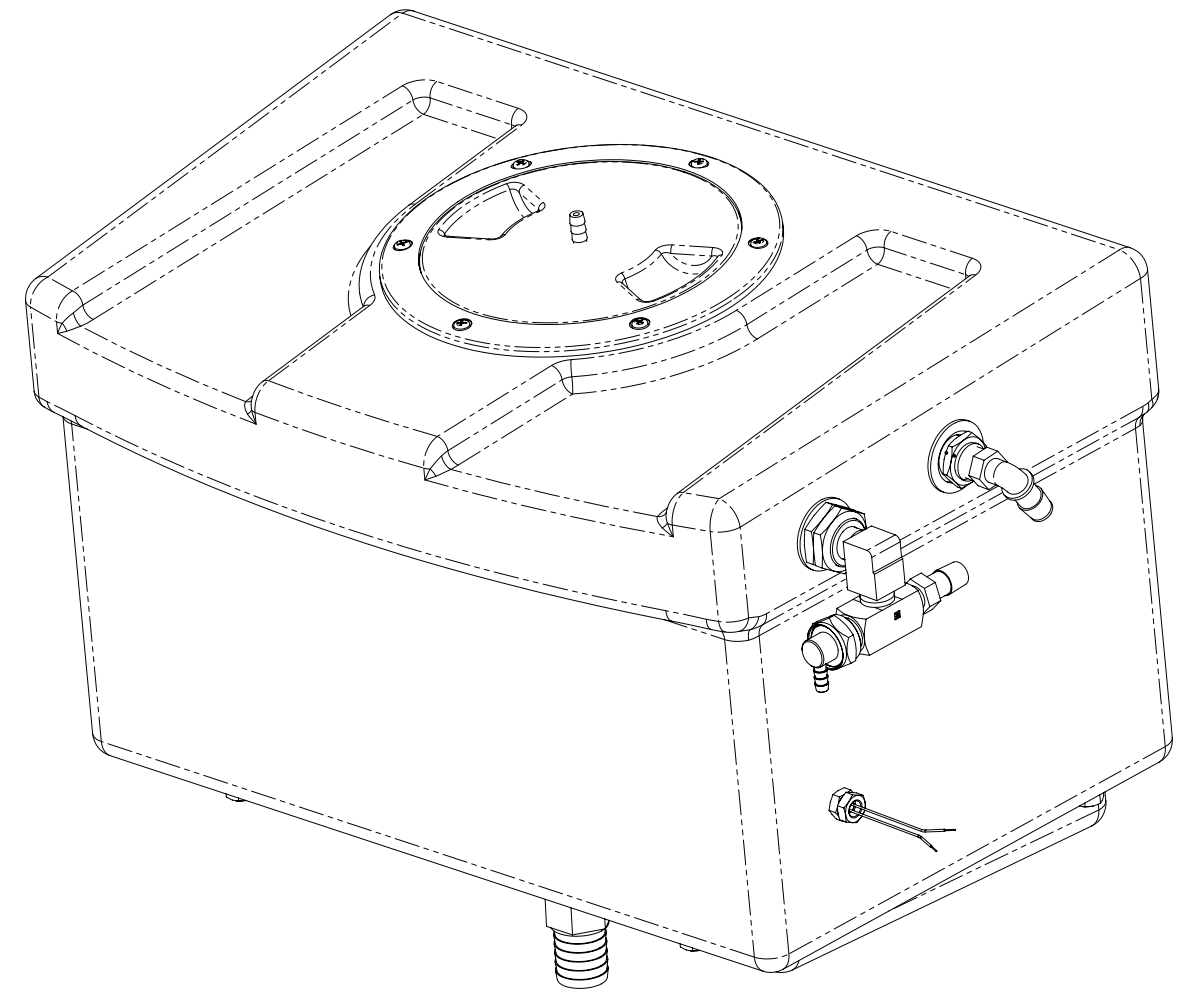
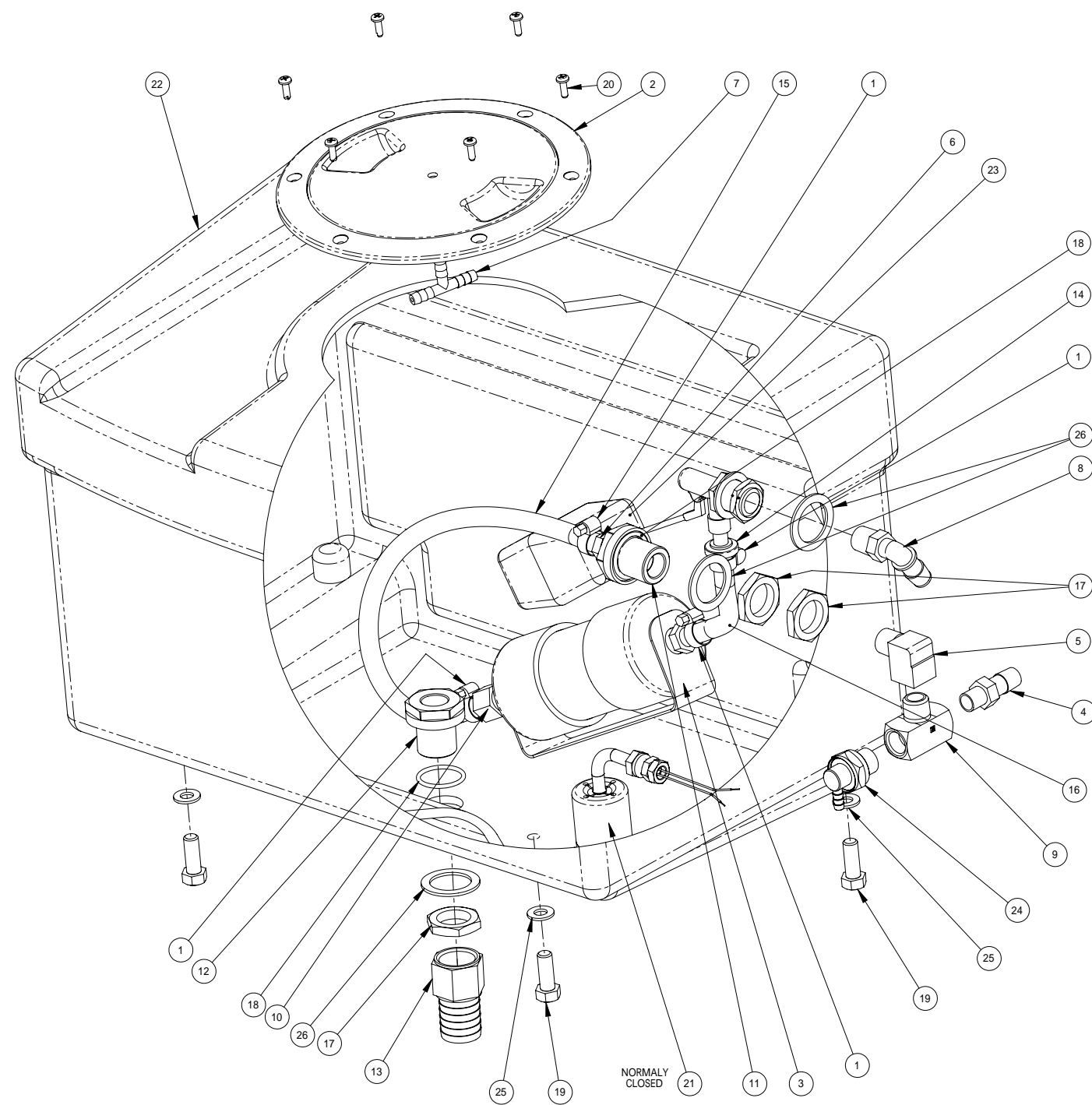

Figure 9-23. Water Box Assembly
7435 Rev. A



TITAN 575

Water Box Assembly Parts List

Item	Part Number	Description	Qty
1	000-033-003	Clamp, Size 4 Mini Hose	4
2	000-041-005	Cover, 6"	1
3	000-049-151	Assembly, Diffuser Filter	1
4	000-052-056	Insert, #68 GFBN	1
5	000-052-086	Elbow, 3/8" NPT Street	1
6	000-052-104	Insert, #66 (3/8" NPT X 3/8" Barb)	1
7	000-052-156	Tee, 1/4" Plastic	1
8	000-052-355	Elbow, 3/8NPT X 1/2" Hose, GFBN	1
9	000-052-447	Tee, 3/8" NPT Male Branch	1
10	000-052-488	Insert, #F66 (3/8" NPT X 3/8" Hose Barb)	1
11	000-052-660	Bulkhead, 3/8" FPT X 3/8" FPT	1
12	000-052-728	Bulkhead, 1/2" FPT	1
13	000-052-754	Insert, #F816 (1/2" FPT X 1" Barb)	1

Item	Part Number	Description	Qty
14	000-052-780	Barbed, Push-Lock	1
15	000-068-326	Hose, 3/8" I.D. Clear w/Braid	1
16	000-068-326	Hose, 3/8" I.D. Clear Braid	1
17	000-094-097	Nut, 1"-14UNS Brass	3
18	000-097-041	O-Ring, 1/2" Bulk Head	2
19	000-143-096	Screw, 3/8"-16UNC X 1.00" Lg. Hex Head	4
20	000-143-314	Screw, #8 X 1/2" Lg. Pan Head	6
21	000-157-0801	Switch, with Protector	1
22	000-159-135	Tank, Poly Water Box 8g - Modified	1
23	000-169-217	Valve, Float, Water Box	1
24	000-169-224	Valve, Mechanical 145°	1
25	000-174-004	Washer, 5/16" Flat	4
26	000-174-063	Washer, 1.5" O.D. X 1.073" I.D. X 0.075" Thk.	3

Figure 9-24. Lower Dash Assembly - View 1 of 2
7437 Rev. B

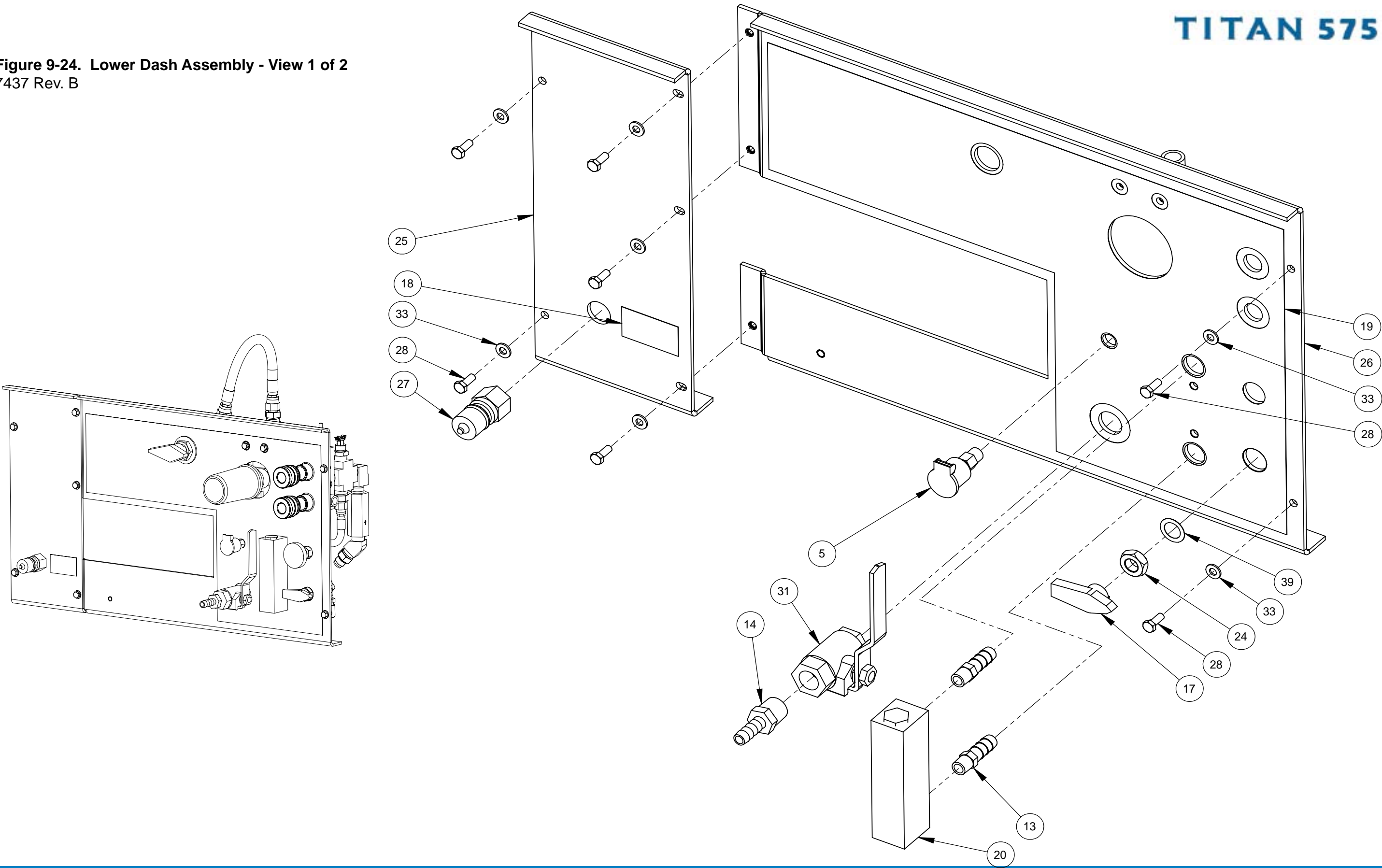

TITAN 575

Figure 9-25. Lower Dash Assembly - View 2 of 2
7437 Rev. B

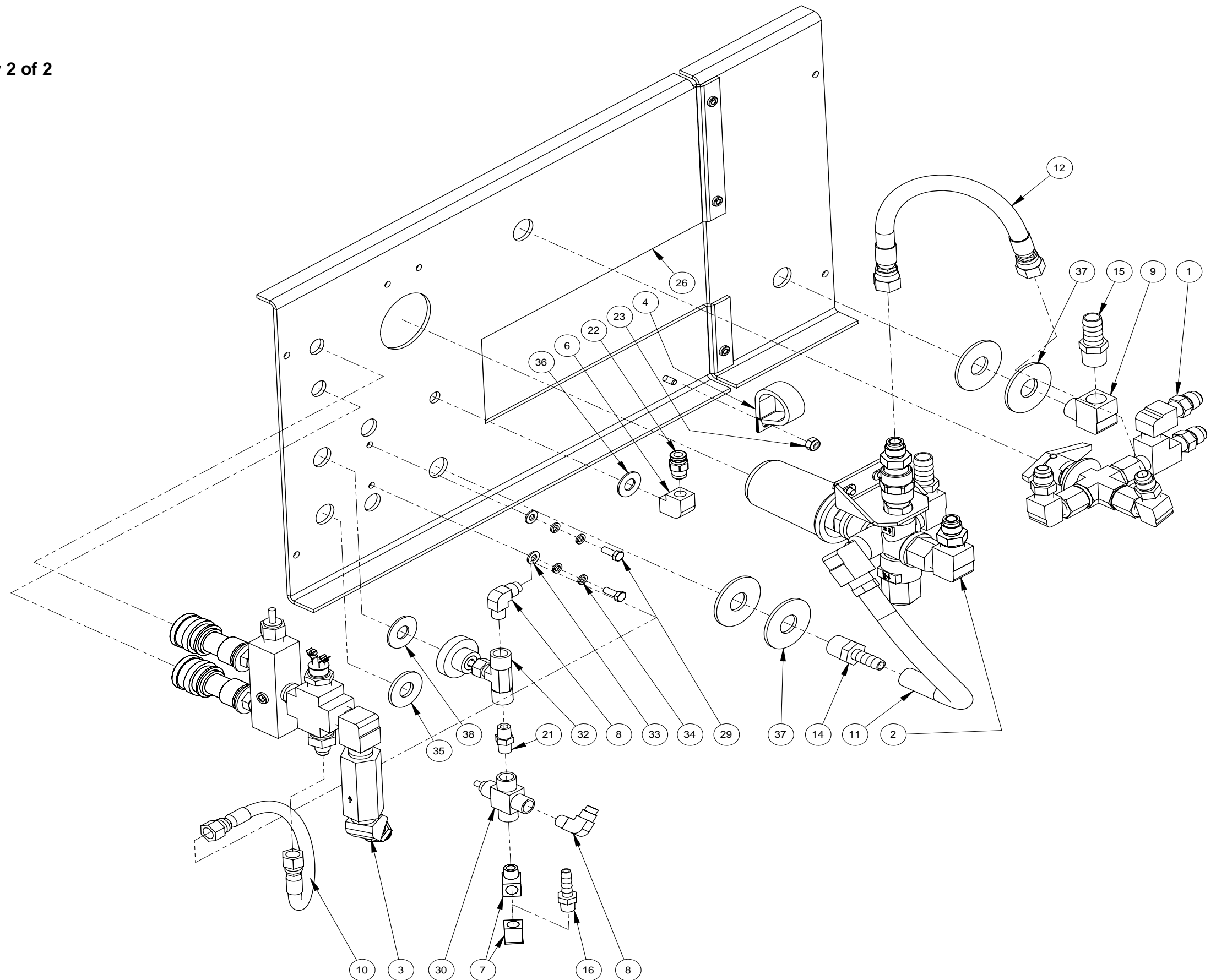

Lower Dash Assembly Parts List

Item	Part Number	Description	Qty
1	---	Assembly, 3 Way Valve	1
2	---	Assembly, By-Pass Valve	1
3	---	Assembly, Hi Pressure Manifold	1
4	000-033-057	Clamp, 1" Cushion Loop	1
5	000-052-272	Cup, Gravity Feed Oil Blower Lube Port	1
6	000-052-089	Elbow, 1/8" NPT Female	1
7	000-052-084	Elbow, 1/8" NPT Street	2
8	000-052-531	Elbow, 1/8" NPT X 1/4" SAE	2
9	000-052-086	Elbow, 3/8" NPT Street	1
10	000-068-790	Hose, 3/16" X 10.5" Lg. Teflon	1
11	000-068-017	Hose, 3/8" I.D. Rubber	1
12	000-068-641	Hose, 3/8" X 10" Teflon w/JIC Ends	1
13	000-052-099	Insert, #26 (1/8" NPT X 3/8" Barb)	2
14	000-052-104	Insert, #66 (3/8" NPT X 3/8" Barb)	2
15	000-052-105	Insert, #68 (3/8" NPT X 1/2" Barb)	1
16	000-052-097	Insert, #24	1
17	---	Knob, 3-Way Ball Valve (Part of 000-169-0171)	1
18	000-081-368	Label, Incoming Fresh Water	1
19	000-081-367	Label, Lower Dash	1
20	000-074-030	Meter, Chemical Flow	1

Item	Part Number	Description	Qty
21	000-052-069	Nipple, 1/8" NPT Hex	1
22	000-052-814	Nipple, 1/8" NPT X 1/4" Pressto Lock	1
23	000-094-034	Nut, #10-24UNC Nylock	1
24	000-094-098	Nut, 7/16"-24UNF - 2 Way Metering Valve	1
25	000-100-185	Panel, Lower Dash - Left	1
26	000-100-181	Panel, Lower Dash - Right	1
27	000-052-052	Quick Connect, 660 3/8" Brass w/ EPDM O-Ring	1
28	000-143-126	Screw, #10-24UNC X 0.50" Lg. Hex Head	7
29	000-143-327	Screw, #10-32UNF X 0.50" Lg. Hex Head	2
30	000-169-0171	Valve, 3-Way Ball O-Ring Style	1
31	000-169-064	Valve, 3/8" NPT Full Port Ball	1
32	000-169-160	Valve, Chemical Metering	1
33	000-174-001	Washer, #10 Flat	9
34	000-174-014	Washer, #10 Lock	4
35	000-174-007	Washer, 1/2" Flat	1
36	000-174-032	Washer, 3/8" Flat	1
37	000-174-008	Washer, 5/8" Flat	4
38	000-174-038	Washer, 7/16" SAE Flat	1
39	000-174-062	Washer, 1/2" I.D. X 3/4" O.D. X 0.010" Thk	1

TITAN 575

Figure 9-26. Side Cover - Machine Assembly
7440 Rev. A

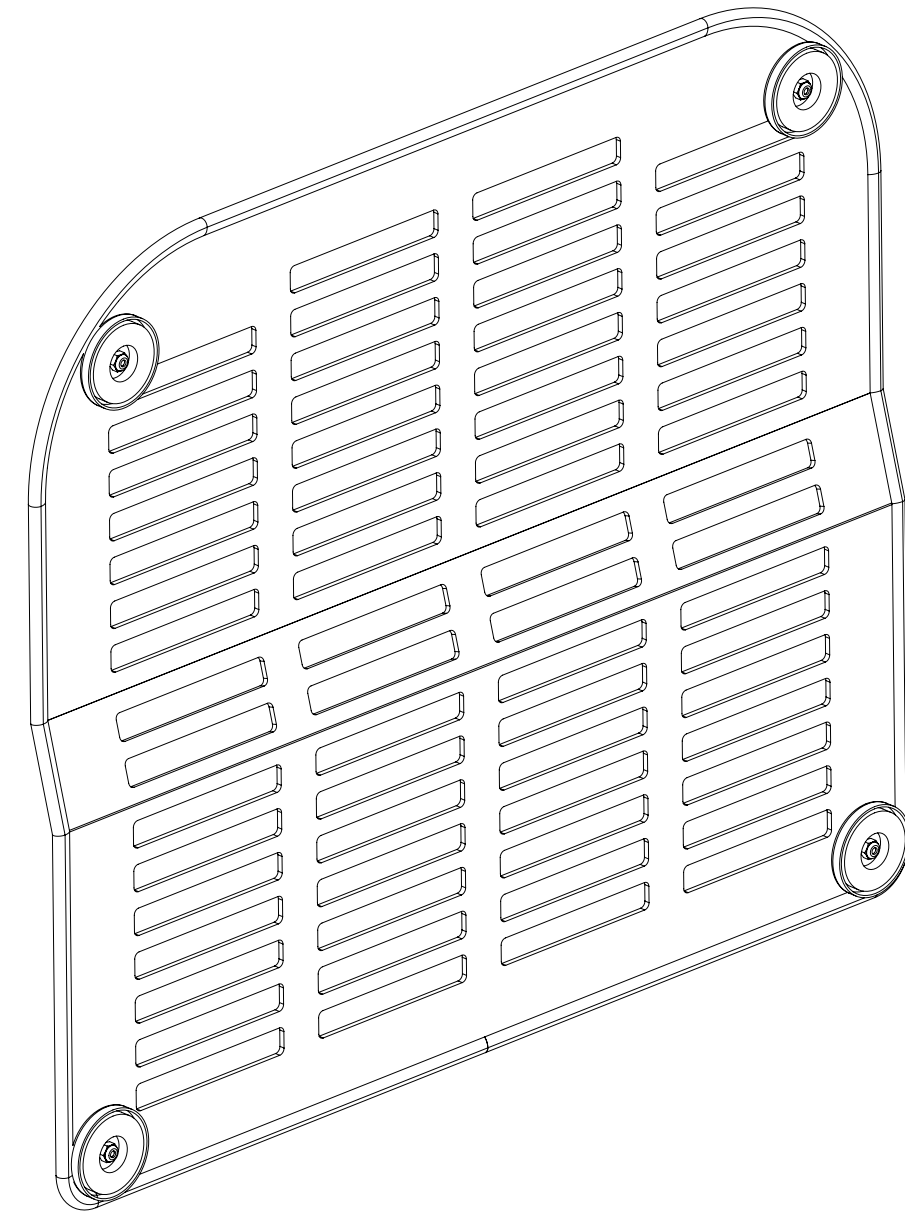
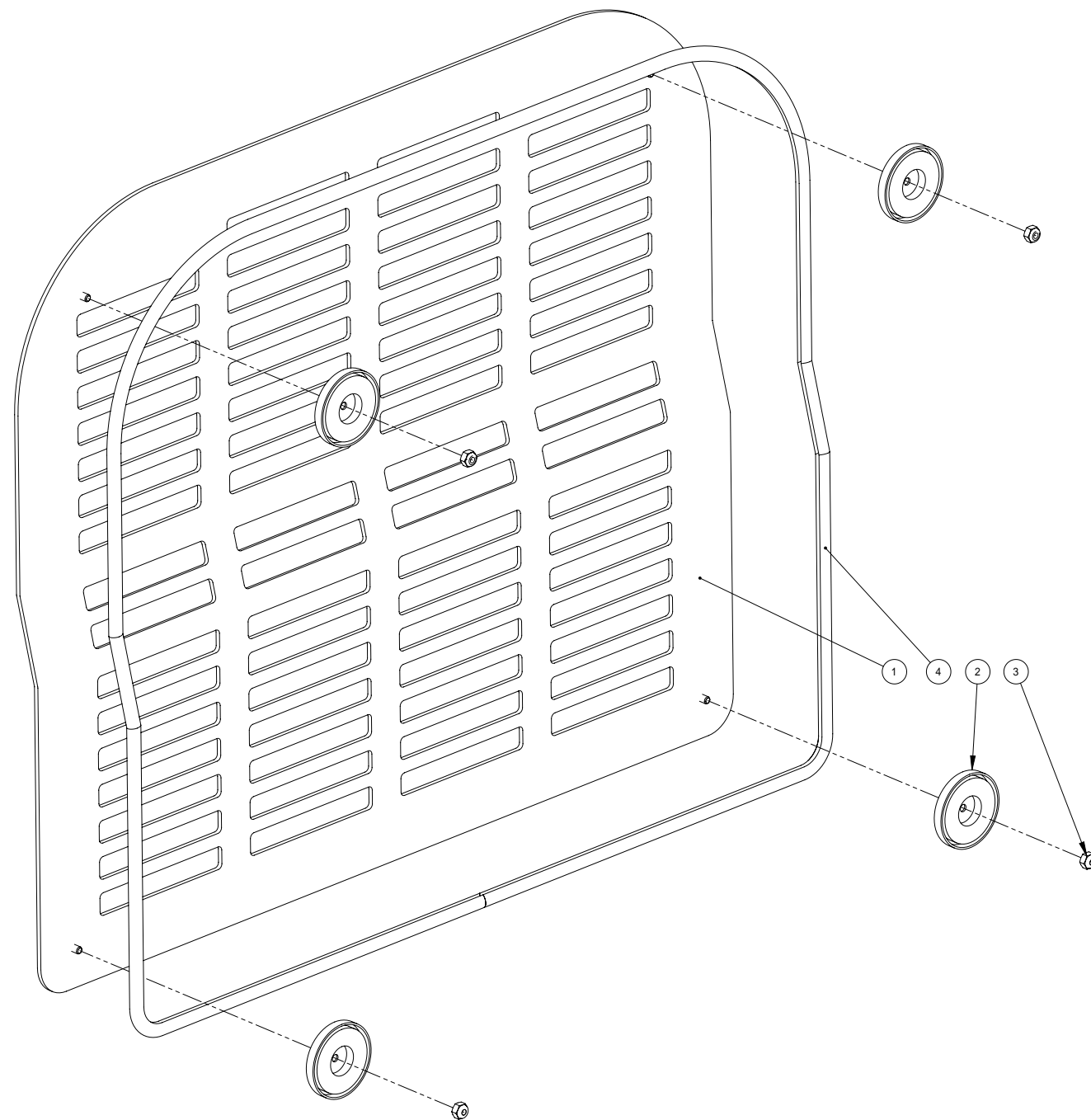

Side Cover Assembly Parts List

Item	Part Number	Description	Qty
1	000-041-469	Cover, Side - Machine	1
2	000-089-003	Magnet	4
3	000-094-034	Nut, #10-24UNC Nylock	4
4	000-131-131	Trimlock, 3/8 X 1/8 Rubber Edge Trim	1

Figure 9-27. Grill Assembly
7441

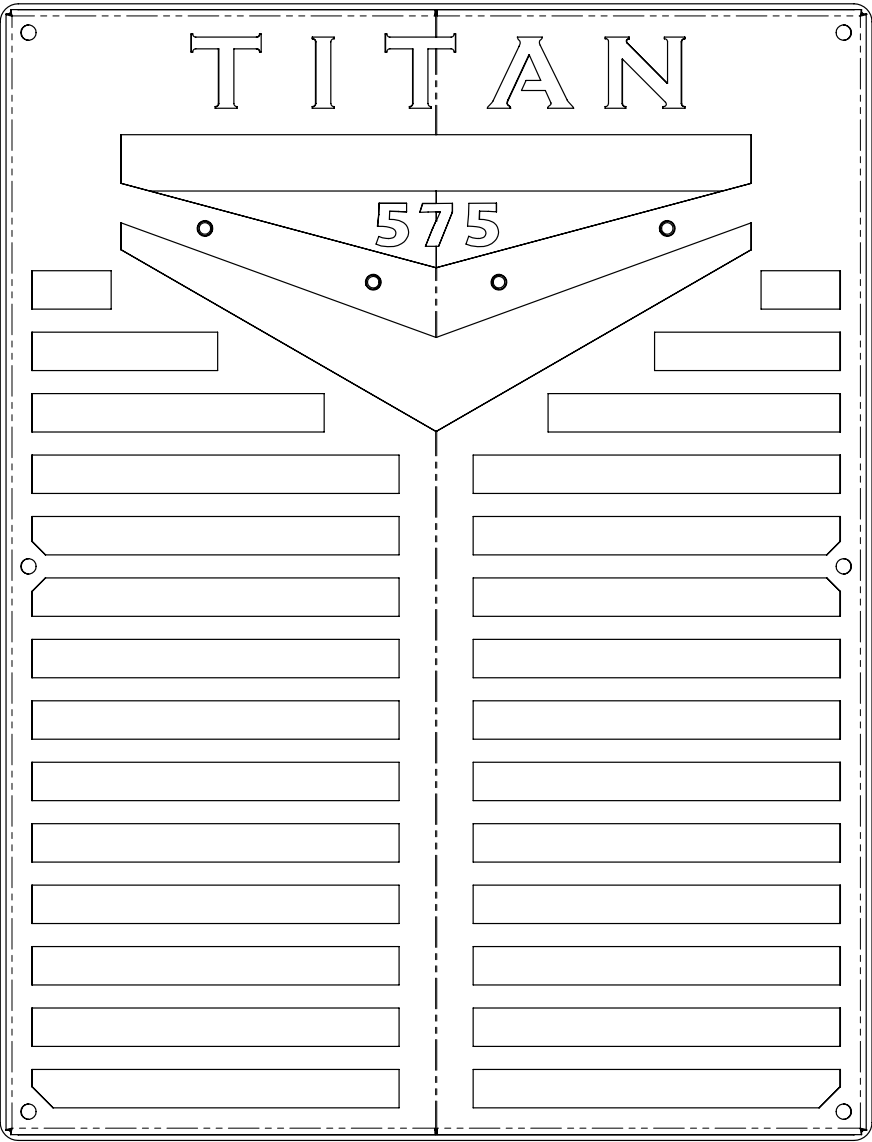
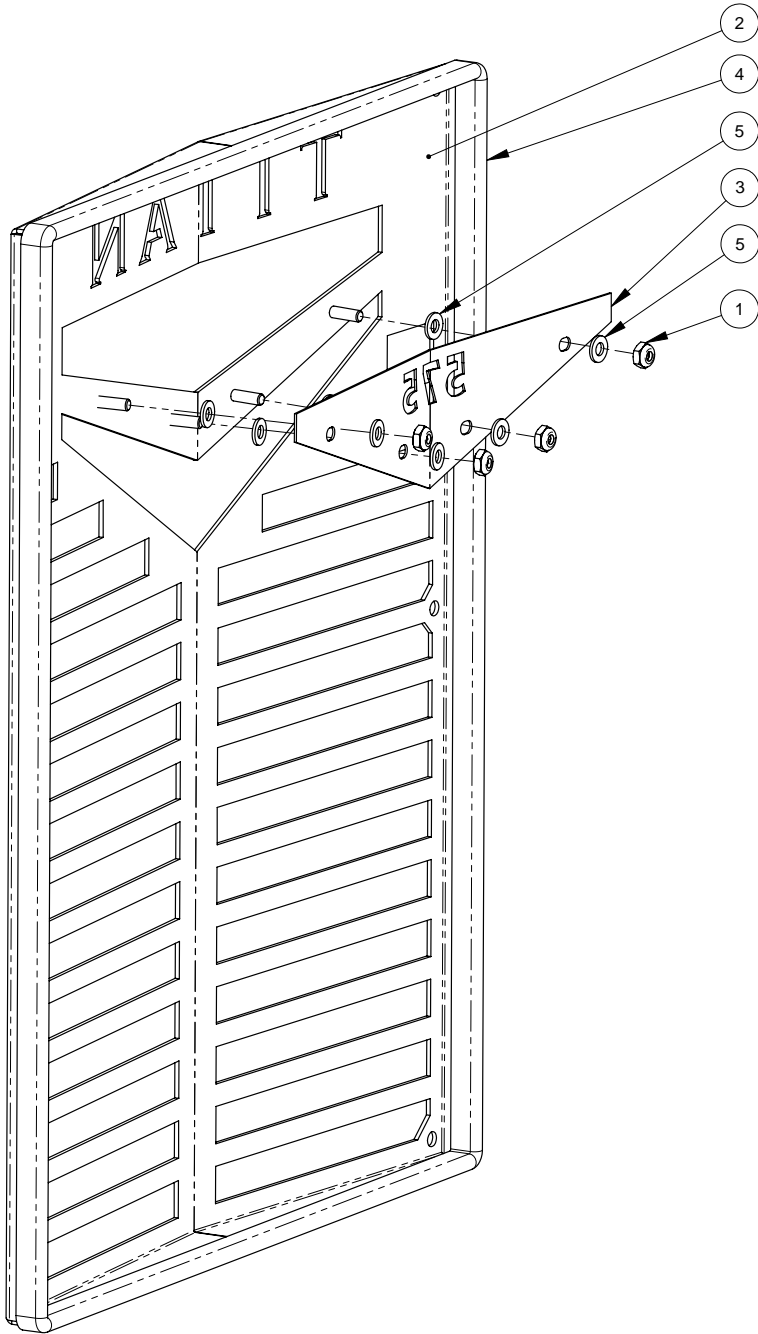

Grill Assembly Parts List

Item	Part Number	Description	Qty
1	000-094-058	Nut, #10-32UNF - Nylock	4
2	000-100-172	Panel, Grill	1
3	000-100-186	Panel, Logo Grill	1
4	000-131-131	Trimlok, 3/8" X 1/8" Groove	1
5	000-174-001	Washer, #10 S/S Flat	8

TITAN 575

Figure 9-28. Blower Heat Exchanger Assembly - View 1 of 2
7442 Rev. A

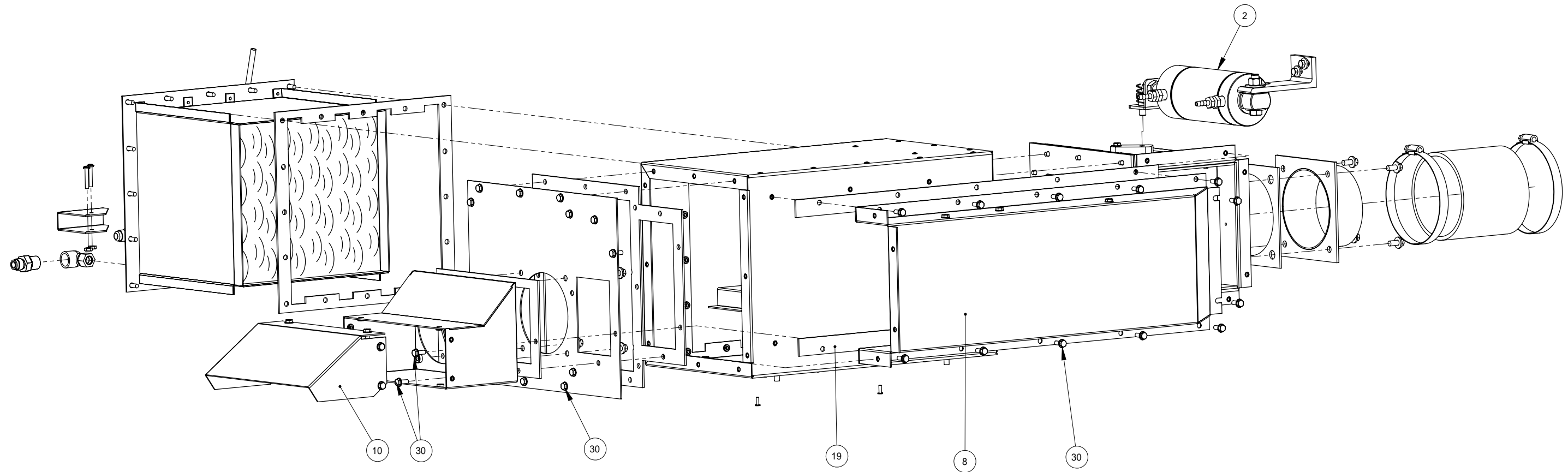
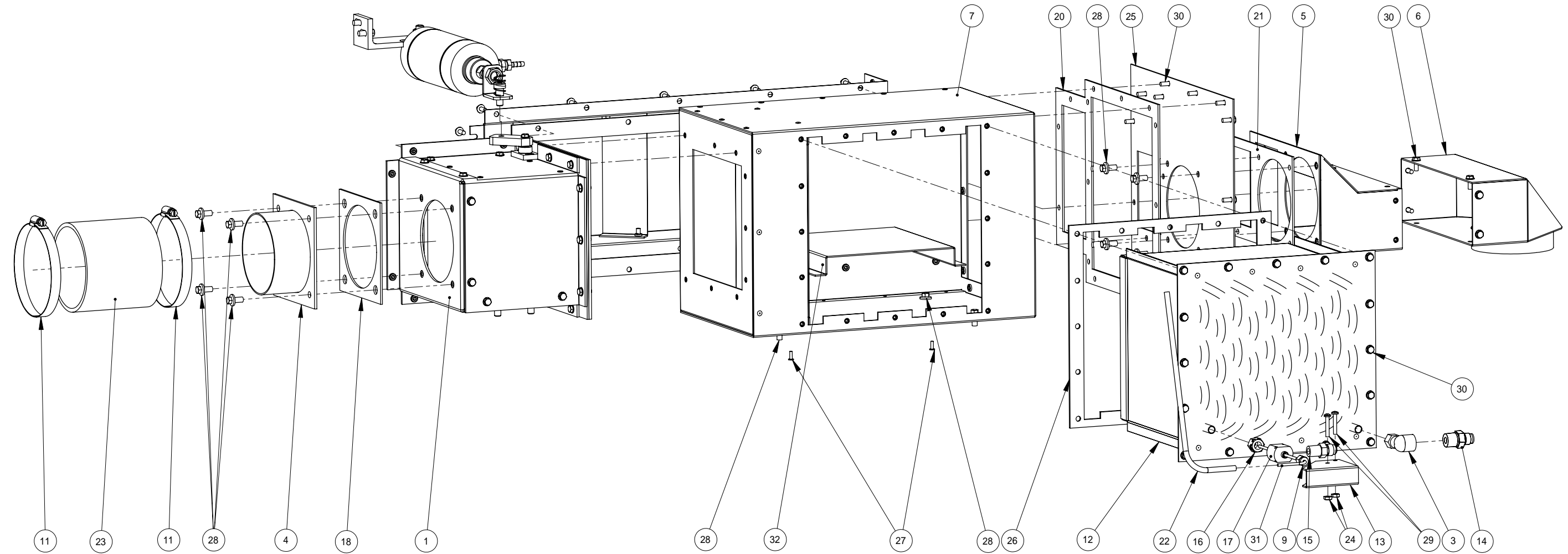

Figure 9-29. Blower Heat Exchanger Assembly - View 2 of 2
7442 Rev. A



TITAN 575

Blower Heat Exchanger Assembly Parts List

Item	Part Number	Description	Qty
1	---	Assembly, Diverter Valve Box	1
2	---	Assembly, Actuator Valve	1
3	---	Elbow, 3/8" FPT X 3/8" Compression (Comes w/ Exchanger)	1
4	000-001-133	Adapter, Tank to 4.0" Blower Hose	1
5	000-001-155	Adapter, Exhaust Duct Outlet	1
6	000-001-173	Adapter, Exhaust Turndown	1
7	000-013-075	Box, Heat Exchanger Inlet and Outlet Plenum	1
8	000-042-064	Housing, Heat Exchanger Divert By-Pass Assembled	1
9	000-052-813	Compression, Fitting 1/4" NPT X 1/8" Tube	1
10	000-001-178	Adapter, Exhaust Turn Down Deflector	1
11	000-033-015	Clamp, 4" Hose	2
12	000-038-073	Core, Heat Exchanger 8" X 8"	1
13	000-041-482	Cover, RTD Sensor	1
14	000-052-528	Nipple, 3/8" M JIC X 3/8" NPT	1
15	000-052-533	Nipple, 3/8" JIC X 1/4" NPT	1

Item	Part Number	Description	Qty
16	000-052-812	Compression, Fitting 1/4" FPT X 3/8" Tube	1
17	000-052-815	Manifold, RTD 1/8" Comp X 3/8" Comp	1
18	000-057-210	Gasket, 4" Exhaust	1
19	000-057-221	Gasket, Side Plenum	1
20	000-057-223	Gasket, Front Plenum	1
21	000-057-225	Gasket, Exhaust Duct Outlet	1
22	000-063-003	Harness Wrap, Hi Temp. 1/4" Gray - Bulk	1
23	000-068-778	Hose, Ø4.0" I.D. X 4" Lg.	1
24	000-094-002	Nut, #8-32UNC Hex S/S	2
25	000-105-556	Plate, Plenum Front	1
26	000-131-015	Gasket, Heat Exchanger Core	1
27	000-140-017	Rivet, 1/8" X 3/8" Blind Pop S/S	2
28	000-143-141	Screw, 1/4"-20UNC X 1/2" Lg. Whiz Lock	12
29	000-143-545	Screw, #8-32 UNC X 1" Lg. PPH	2
30	000-143-583	Screw, #10-24UNC X 0.50" Lg. Hex Head Flange Z/P	49
31	000-149-566	Sensor, 6" - 90° RTD	1
32	000-154-176	Spacer, Heat Exchanger Support - Bottom	1

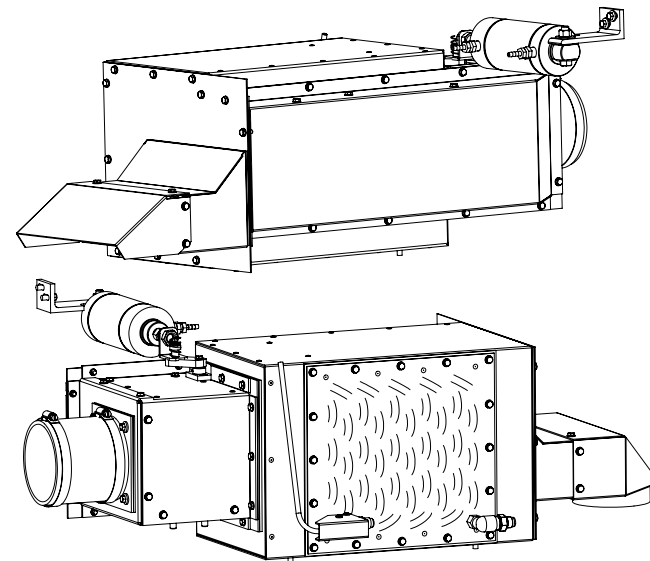
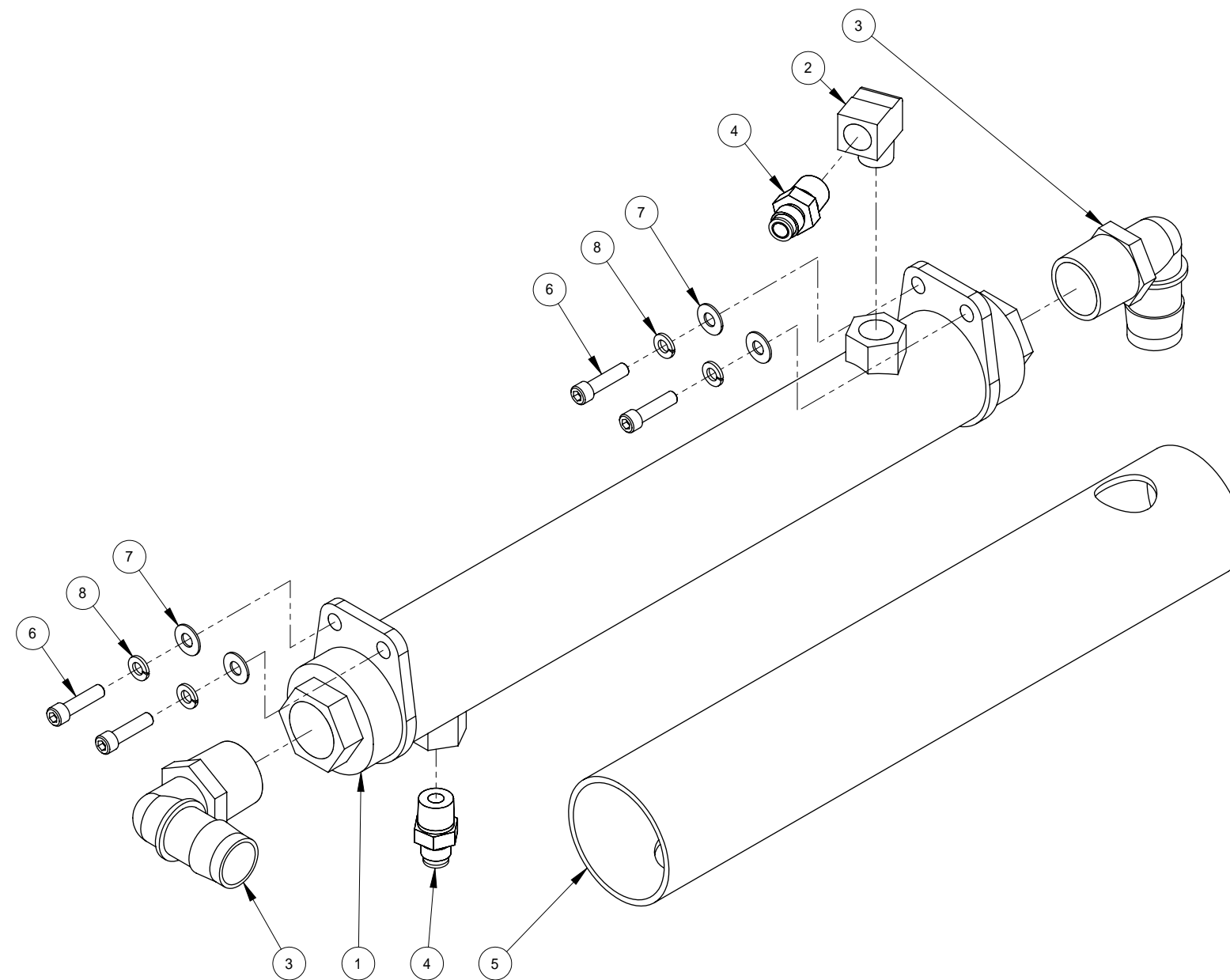
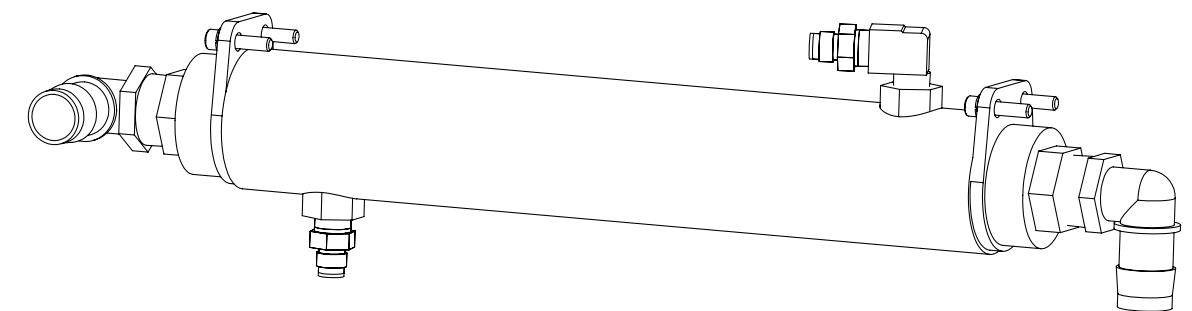

Figure 9-30. Coolant Heat Exchanger Assembly
7443



Coolant Heat Exchanger Assembly Parts List

Item	Part Number	Description	Qty
1	000-038-043	Heat Exchanger, Water to Water	1
2	000-052-086	Elbow, 3/8" NPT Street	1
3	000-052-131	Elbow, 1"NPT X 1" Barb (Glass Filled Black Nylon)	2
4	000-052-528	Nipple, 3/8" M JIC X 3/8" NPT	2
5	000-108-134	Protector, Coolant Exchanger Gray Silicone Blanket	1
6	000-143-080	Screw, 1/4"-20UNC X 1.00" Lg. Socket Head	4
7	000-174-003	Washer, 1/4" Flat	4
8	000-174-019	Washer, 1/4" Lock	4



TITAN 575

Figure 9-31. Diverter Valve Assembly
7446 Rev. A

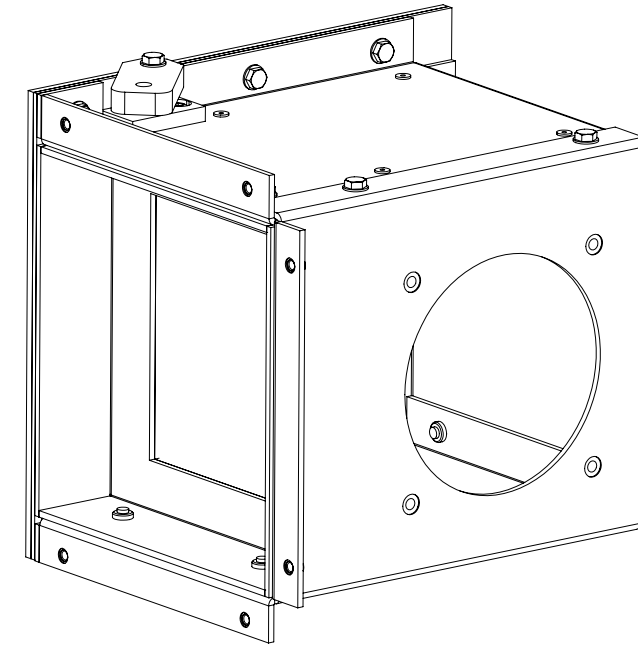
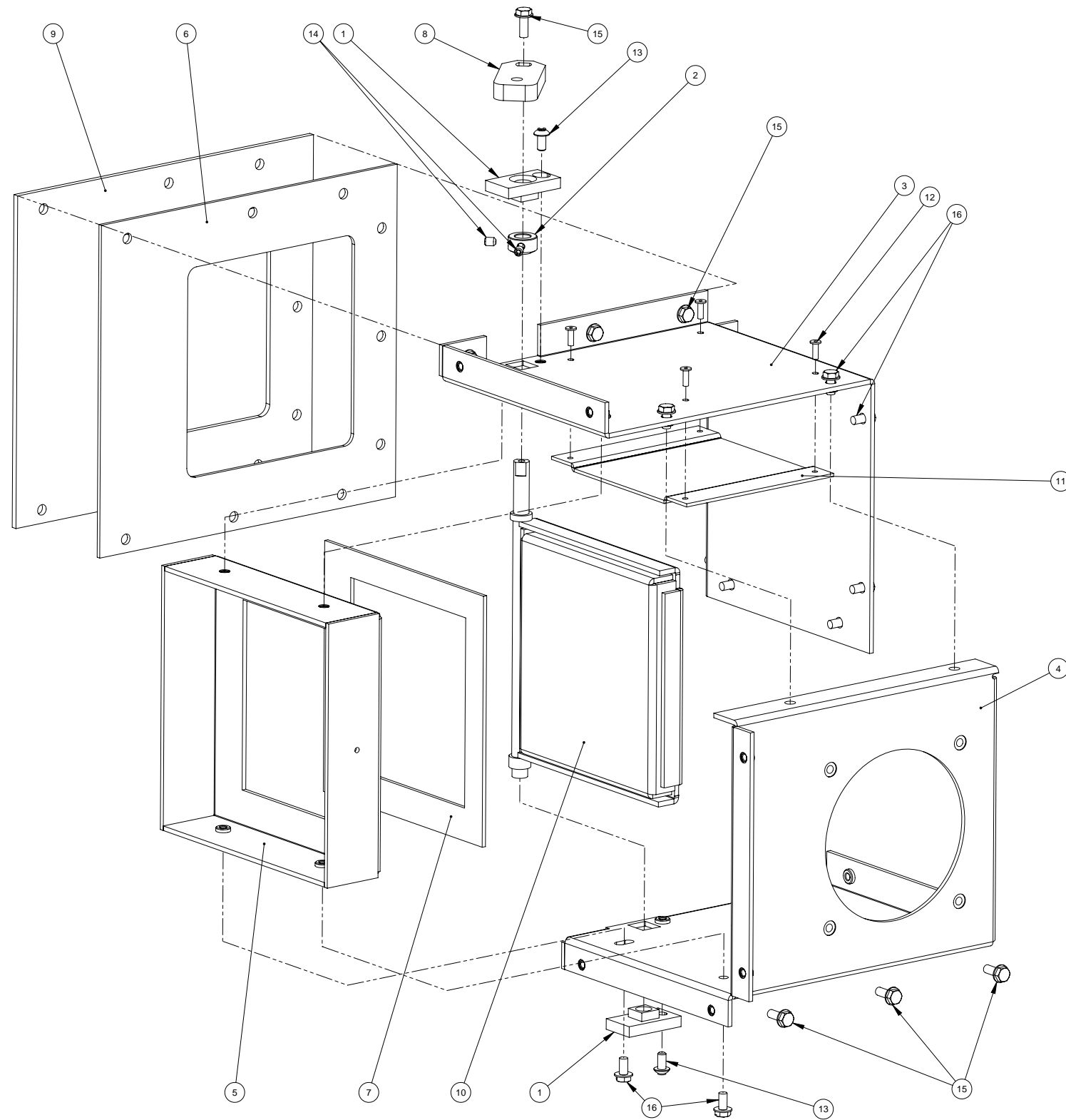

Diverter Valve Box Assembly Parts List

Item	Part Number	Description	Qty
1	000-020-069	Bushing, Flapper - Diverter Box	2
2	000-020-073	Collar, Diverter Alignment	1
3	000-042-065	Housing, Top and Side - Diverter Box	1
4	000-042-066	Housing, Bottom and Side - Diverter Box	1
5	000-042-067	Housing, Baffle - Diverter Box	1
6	000-057-219	Gasket, Diverter to Exchanger Box	1
7	000-057-220	Gasket, Diverter Baffle	1
8	000-085-031	Linkage, Diverter Actuation	1
9	000-105-551	Plate, Sealing - Diverter Box	1
10	000-105-552	Plate, Flapper - Diverter Box - Weldment	1
11	000-108-151	Protector, Exhaust Deflector - Diverter Box	1
12	000-140-017	Rivet, 1/8" X 3/8" Blind Pop S/S	4
13	000-143-107	Screw, #10-24UNC X 3/8" Lg. Button Head Socket	2
14	000-143-111	Set Screw, #10-24UNC X 0.25" Lg.	2
15	000-143-583	Screw, #10-24UNC X 0.50" Lg. Hex Head Flange Z/P	10
16	000-143-705	Screw, #10-24UNC X 3/8" Lg. Whiz Head	10

Figure 9-32. By-Pass Valve Assembly
7447

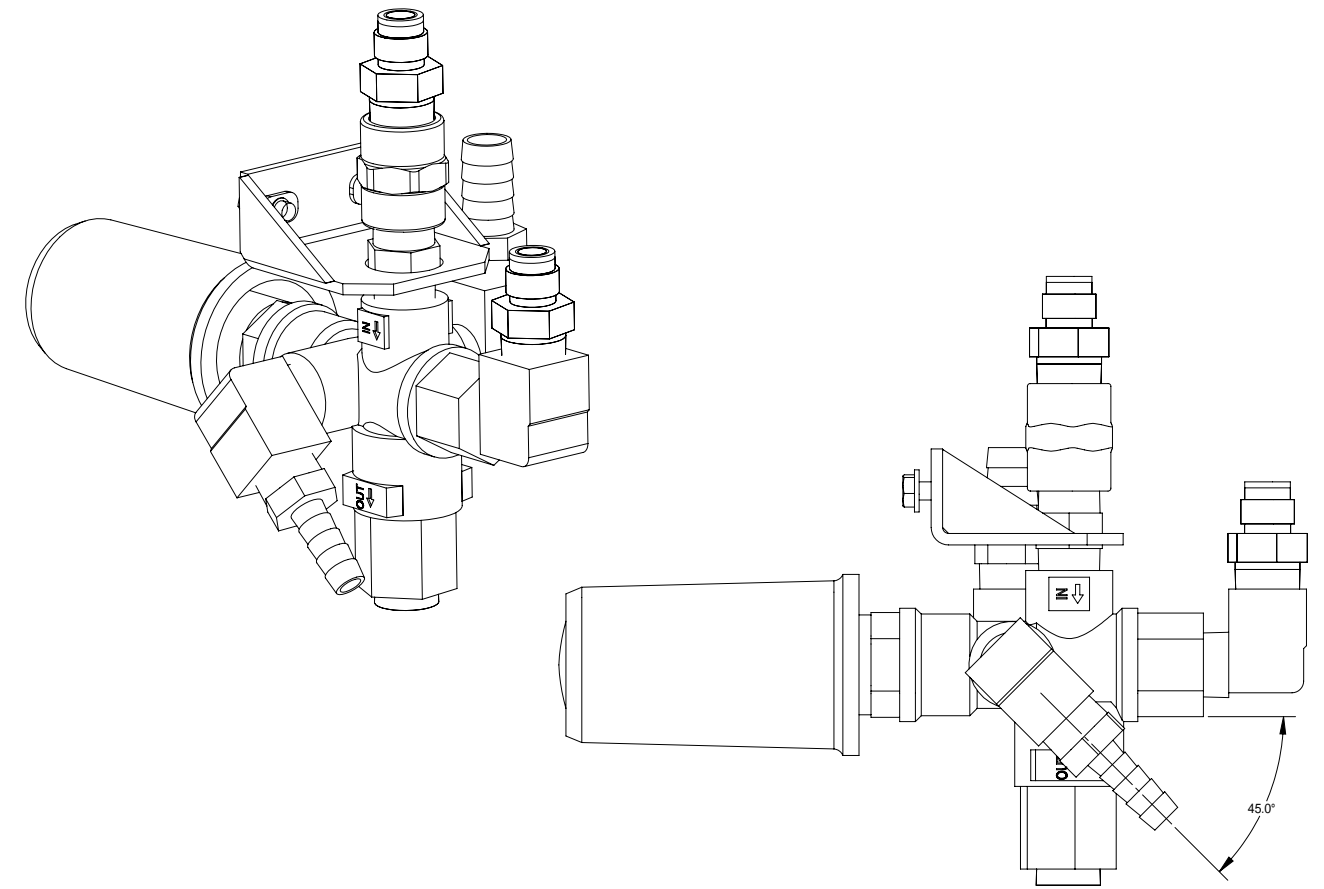
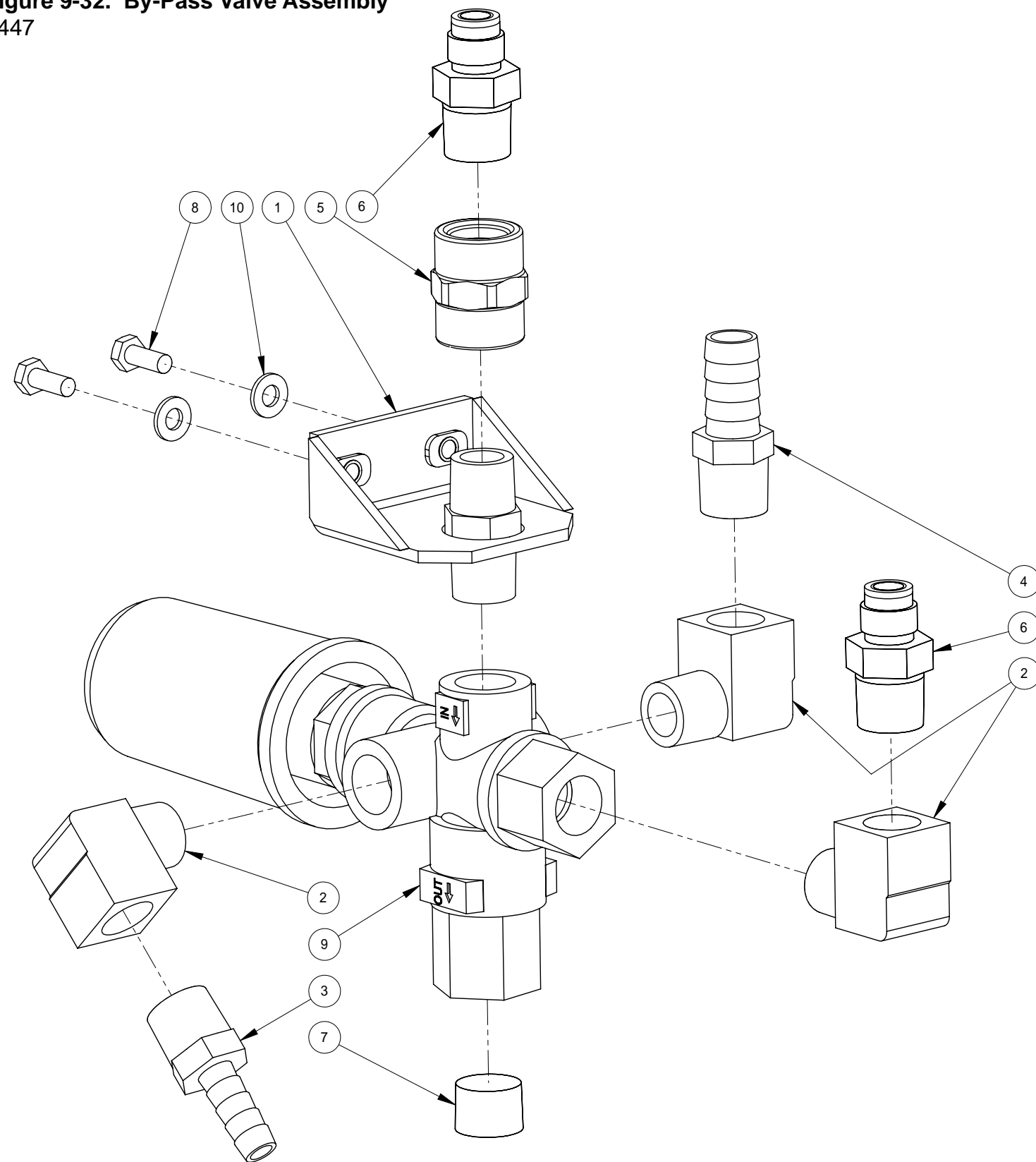

By-Pass Valve Assembly Parts List

Item	Part Number	Description	Qty
1	000-015-515	Bracket, By-Pass Valve Mounting	1
2	000-052-086	Elbow, 3/8" NPT Street	3
3	000-052-104	Insert, #66 (3/8" NPT X 3/8" Barb)	1
4	000-052-105	Insert, #68 (3/8" NPT X 1/2" Barb)	1
5	000-052-414	Coupler, 3/8" FPT Brass	1
6	000-052-528	Nipple, 3/8" M JIC X 3/8" NPT	2
7	000-106-008	Plug, 3/8" NPT Allen Head	1
8	000-143-126	Screw, #10-24UNC X 0.50" Lg. Hex Head	2
9	000-169-188	Valve, Pa Press Reg Mod	1
10	000-174-001	Washer, #10 S/S Flat	2

TITAN 575

Figure 9-33. 3-Way Valve Assembly
7448

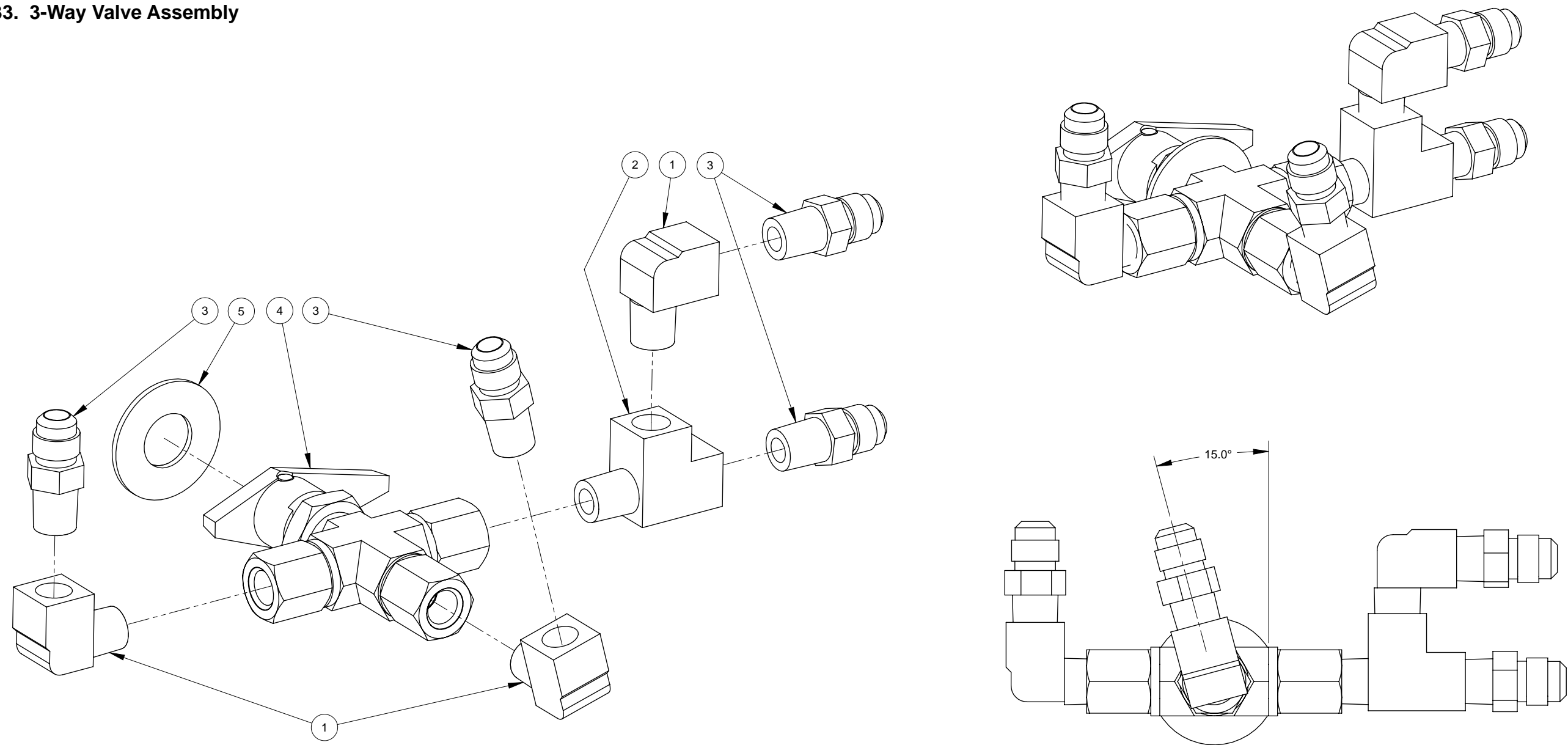

3-Way Valve Assembly Parts List

Item	Part Number	Description	Qty
1	000-052-085	Elbow, 1/4" NPT Street	3
2	000-052-090	Tee, 1/4" NPT Branch M-F-F	1
3	000-052-533	Nipple, 3/8" JIC X 1/4" NPT	4
4	000-169-213	Valve, 3-Way 1/4" FPT	1
5	000-174-034	Washer, 0.688" I.D. X 1.50" O.D. X 0.078" Thk.	1

Figure 9-34. Actuator Valve Assembly
7450 Rev. A

Actuator Valve Assembly Parts List

Item	Part Number	Description	Qty
1	000-042-069	Mount, Air Cylinder	1
2	000-042-070	Mount, Air Cylinder Extension - Welded	1
3	000-052-059	Bushing, 1/4" MPT X 1/8" FPT	2
4	000-052-293	Insert, #23 (1/8" NPT X 3/16" Barb)	2
5	000-057-224	Gasket, Actuator	1
6	000-094-014	Nut, 3/8-16 Hex Z/P	1
7	000-094-122	Nut, 1/2"-20UNF Hex Jam	1
8	000-143-022	Screw, 3/8-16UNC X 1.75" Hex Head - Grade 8	1
9	000-143-141	Screw, 1/4"-20UNC X 1/2" Lg. Whiz Lock	2
10	000-143-573	Screw, 5/16"-18UNC X 7/8" Lg. w/ 3/8" X 1/2"	1
11	000-155-020	Spring, 0.540 O.D. X 0.041 Wire X 1.00 Lg.	1
12	000-169-225	Valve, Ø2.5" Air Cylinder	1
13	000-174-032	Washer, 3/8" Flat	2

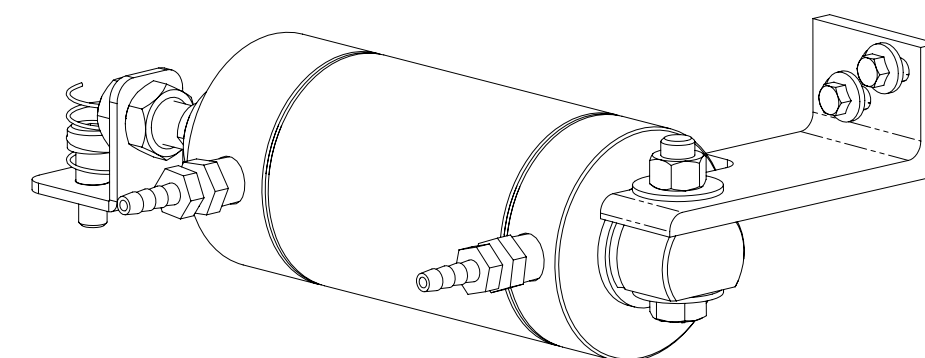
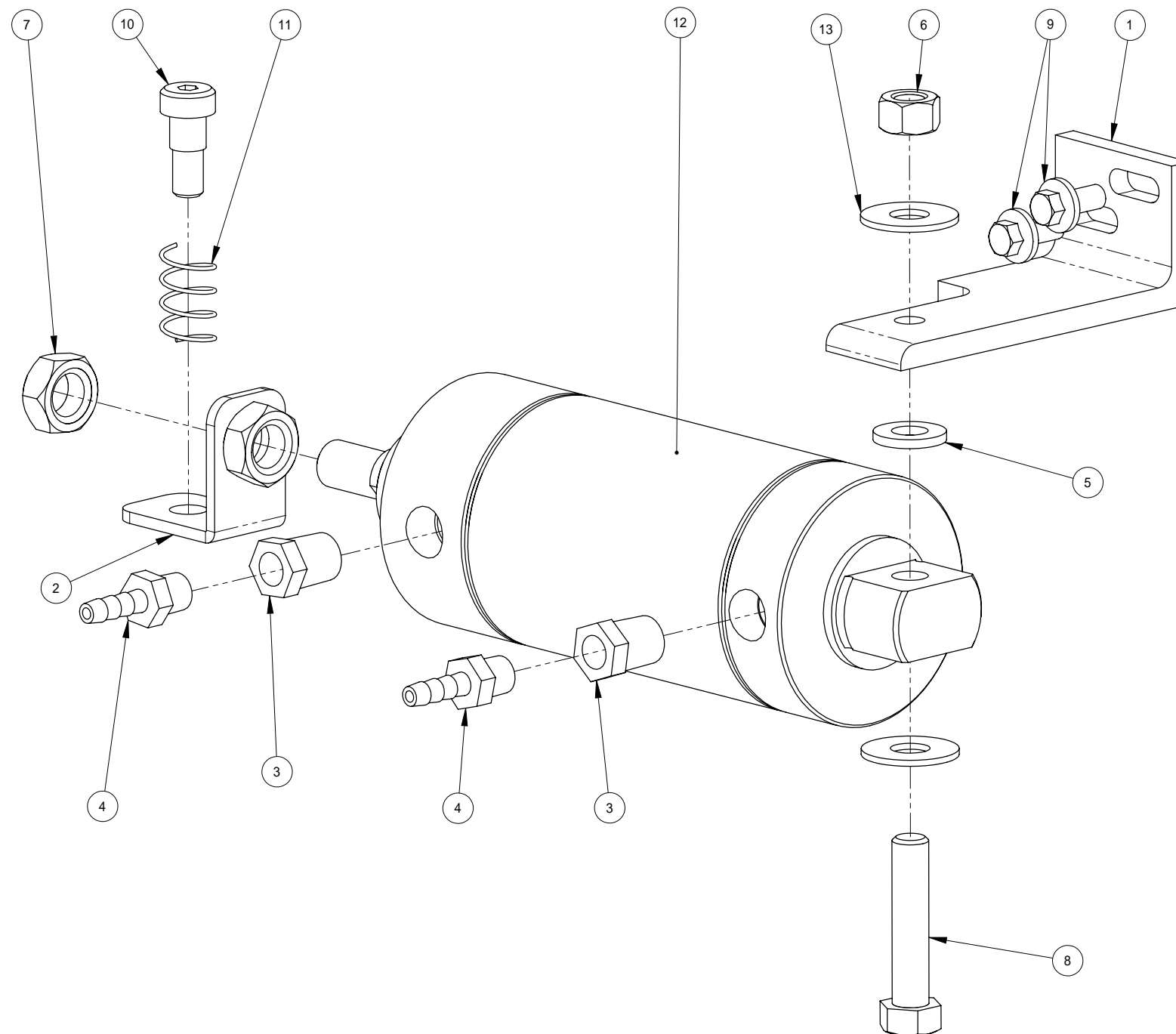

TITAN 575

Figure 9-35. Hi Pressure Manifold Assembly
7453

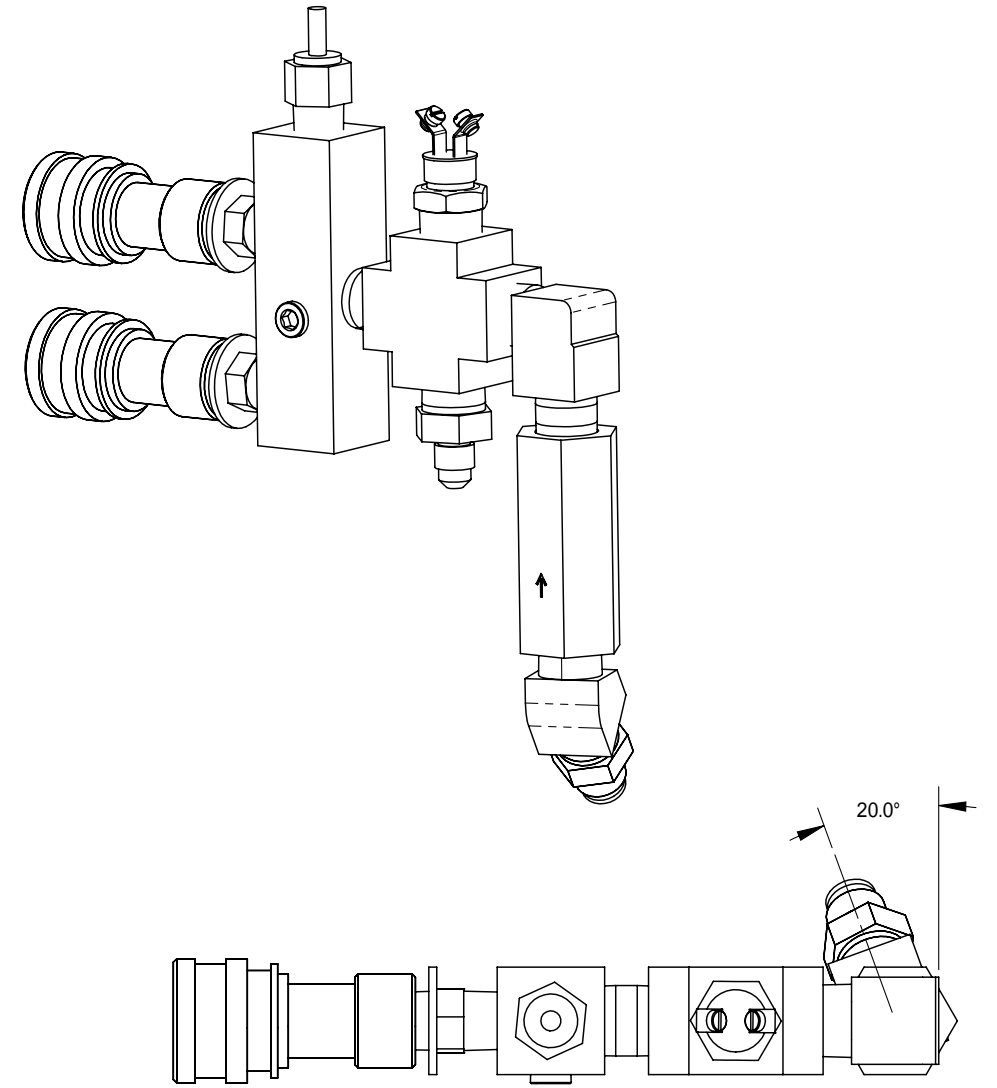
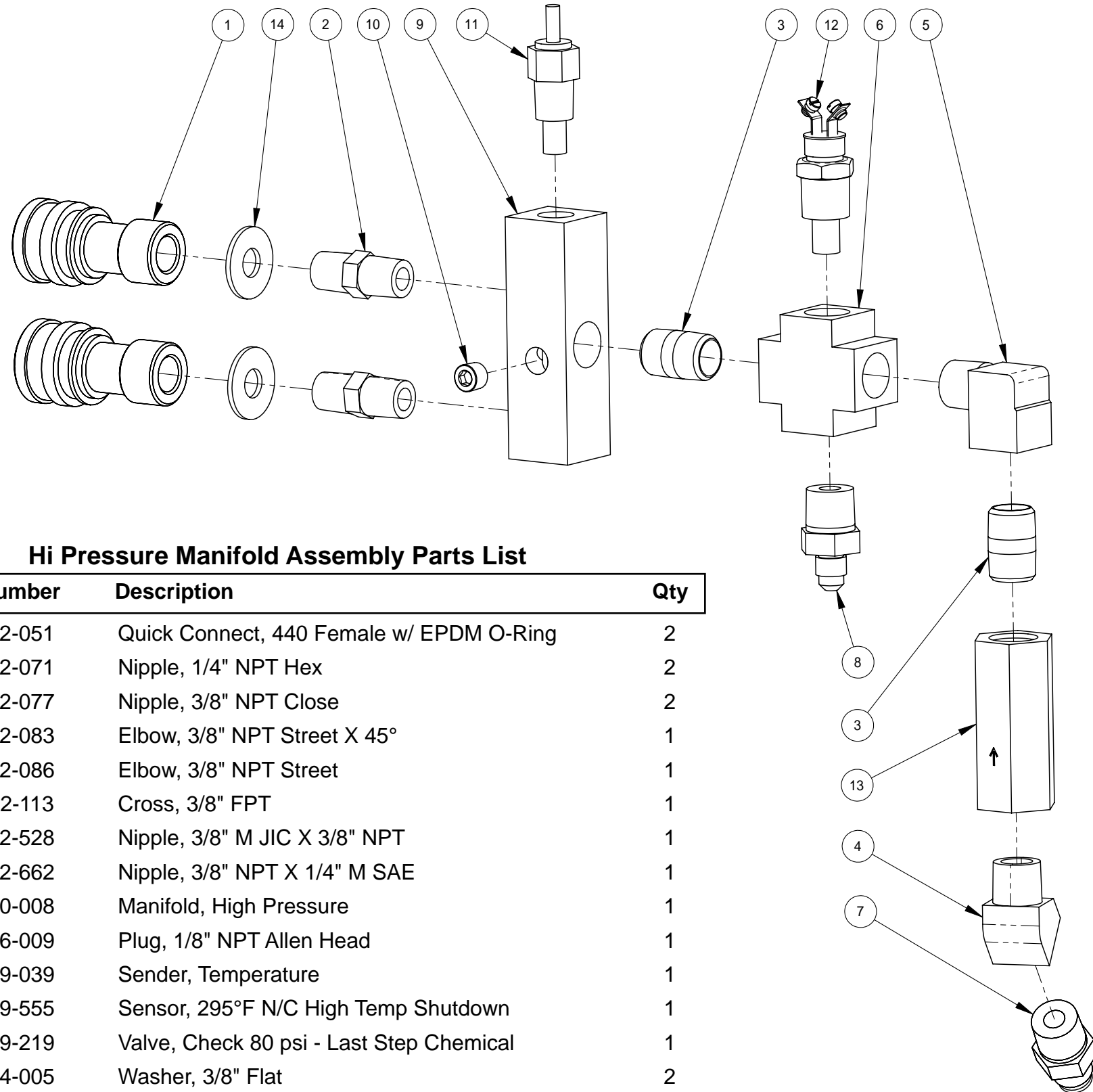

Hi Pressure Manifold Assembly Parts List

Item	Part Number	Description	Qty
1	000-052-051	Quick Connect, 440 Female w/ EPDM O-Ring	2
2	000-052-071	Nipple, 1/4" NPT Hex	2
3	000-052-077	Nipple, 3/8" NPT Close	2
4	000-052-083	Elbow, 3/8" NPT Street X 45°	1
5	000-052-086	Elbow, 3/8" NPT Street	1
6	000-052-113	Cross, 3/8" FPT	1
7	000-052-528	Nipple, 3/8" M JIC X 3/8" NPT	1
8	000-052-662	Nipple, 3/8" NPT X 1/4" M SAE	1
9	000-090-008	Manifold, High Pressure	1
10	000-106-009	Plug, 1/8" NPT Allen Head	1
11	000-149-039	Sender, Temperature	1
12	000-149-555	Sensor, 295°F N/C High Temp Shutdown	1
13	000-169-219	Valve, Check 80 psi - Last Step Chemical	1
14	000-174-005	Washer, 3/8" Flat	2

Figure 9-36. 70 Gallon Universal Recovery Tank (URT) Assembly
7454

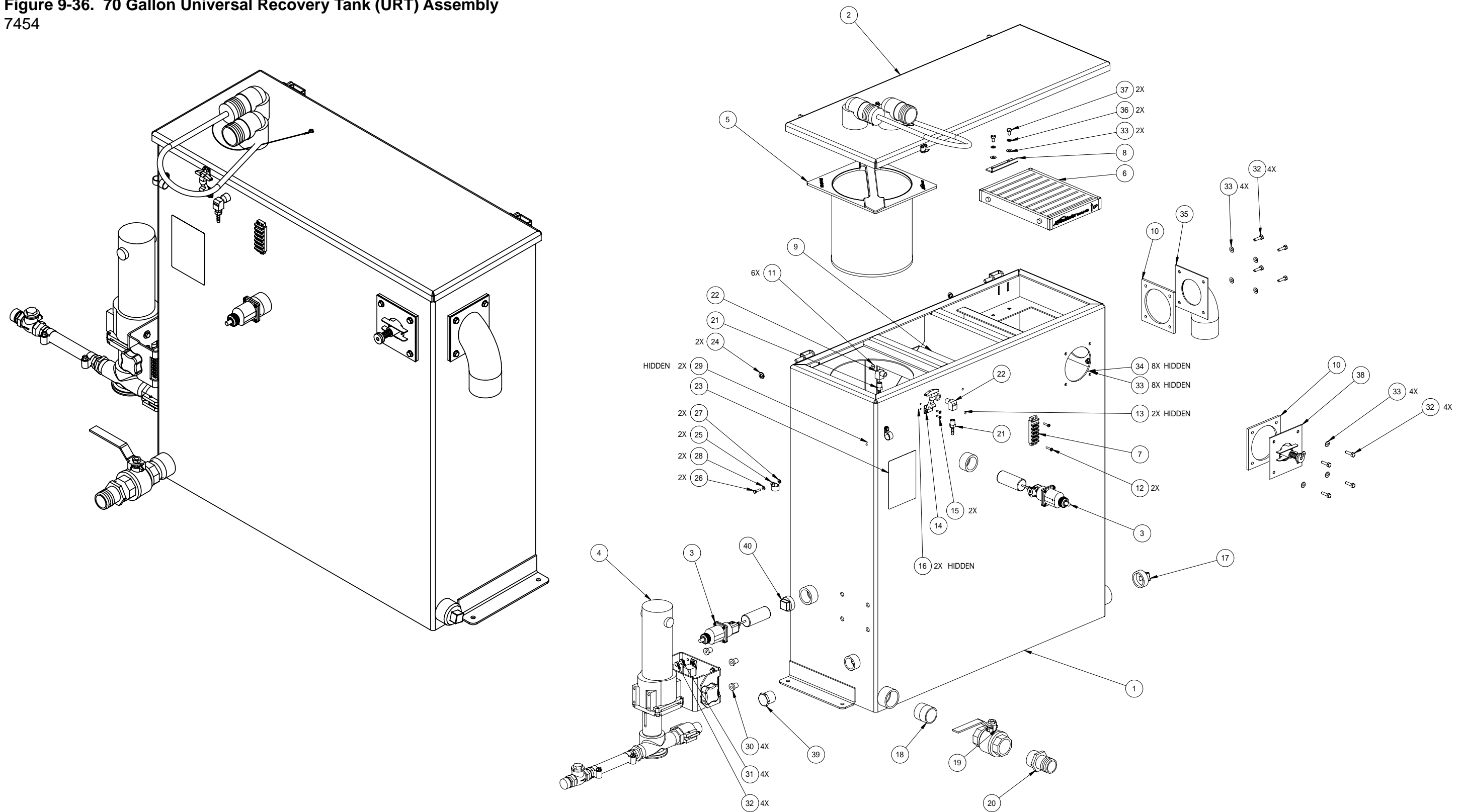

TITAN 575

70 Gallon Universal Recovery Tank (URT) Assembly Parts List

Item	Part Number	Description	Qty
1	000-159-128	Tank, 70 Gallon URT - Weldment	1
2	--	Assembly, Cover, 70 Gal, Dual Vac, URT	1
3	000-157-091	Float, Lever Switch	2
4	--	Assembly, Dura-Flow APO	1
5	000-049-152	Filter, Recovery Tank Basket	1
6	000-049-153	Filter, Flat - URT	1
7	000-012-002	Block, 6-Post Terminal	1
8	000-015-932	Bracket, Flat Filter Securing	1
9	000-049-154	Deflector, Air - URT	1
10	000-057-206	Gasket, Adapter - URT	2
11	000-140-023	Rivet, AB8-6A Aluminum Pop	6
12	000-143-051	Screw, #8-32UNC X 3/4" Lg. Binder Head	2
13	000-094-059	Nut, #8-32UNC Nylock	2
14	000-086-008	Latch, Bungie	1
15	000-143-539	Screw, #6-32UNC X 0.50" Lg. Button Head	2
16	000-094-063	Nut, #6-32UNC Nylock	2
17	000-106-019	Plug, 1-1/2" NPT	1
18	000-052-763	Nipple, 1-1/2" IPS Close S/S	1
19	000-169-022	Valve, 1-1/2" Full Port Ball	1
20	000-052-226	Insert, 1-1/2" NPT X 1-1/2" Barb (Gray)	1

Item	Part Number	Description	Qty
21	000-052-100	Insert, #44	2
22	000-052-085	Elbow, 1/4" NPT Street	2
23	--	Label, Maintenance and Lube Schedule	1
24	000-174-029	Washer, 3/8" Rubber-Backed	2
25	000-033-023	Clamp, 3/4" Nylon Hose	2
26	000-143-132	Screw, #10-24UNC X 0.75" Lg. Hex Head	2
27	000-174-036	Washer, #10 Flat Rubber-Backed	2
28	000-174-001	Washer, #10 S/S Flat	2
29	000-094-034	Nut, #10-24UNC Nylock	2
30	000-094-113	Nut, 1/4"-20UNC Neoprene Wellnut	4
31	000-174-060	Washer, 1/4" Rubber-Backed	4
32	000-143-002	Screw, 1/4"-20UNC X 1.00" Lg. Hex Head	12
33	000-174-003	Washer, 1/4" Flat	18
34	000-094-009	Nut, 1/4"-20UNC Nylock	8
35	000-001-135	Adapter, Tank to Ø3.0 X 90° Blower Hose	1
36	000-174-019	Washer, 1/4" Lock	2
37	000-143-333	Screw, 1/4"-20UNC X 0.50" Lg. Hex Head	2
38	601-050-001	Assembly, Vacuum Relief Valve - URT	1
39	000-106-049	Plug, 1" NPT Black Nylon	1
40	000-106-046	Plug, 1-1/4" NPT	1

Figure 9-37. 100 Gallon Universal Recovery Tank Assembly 7451

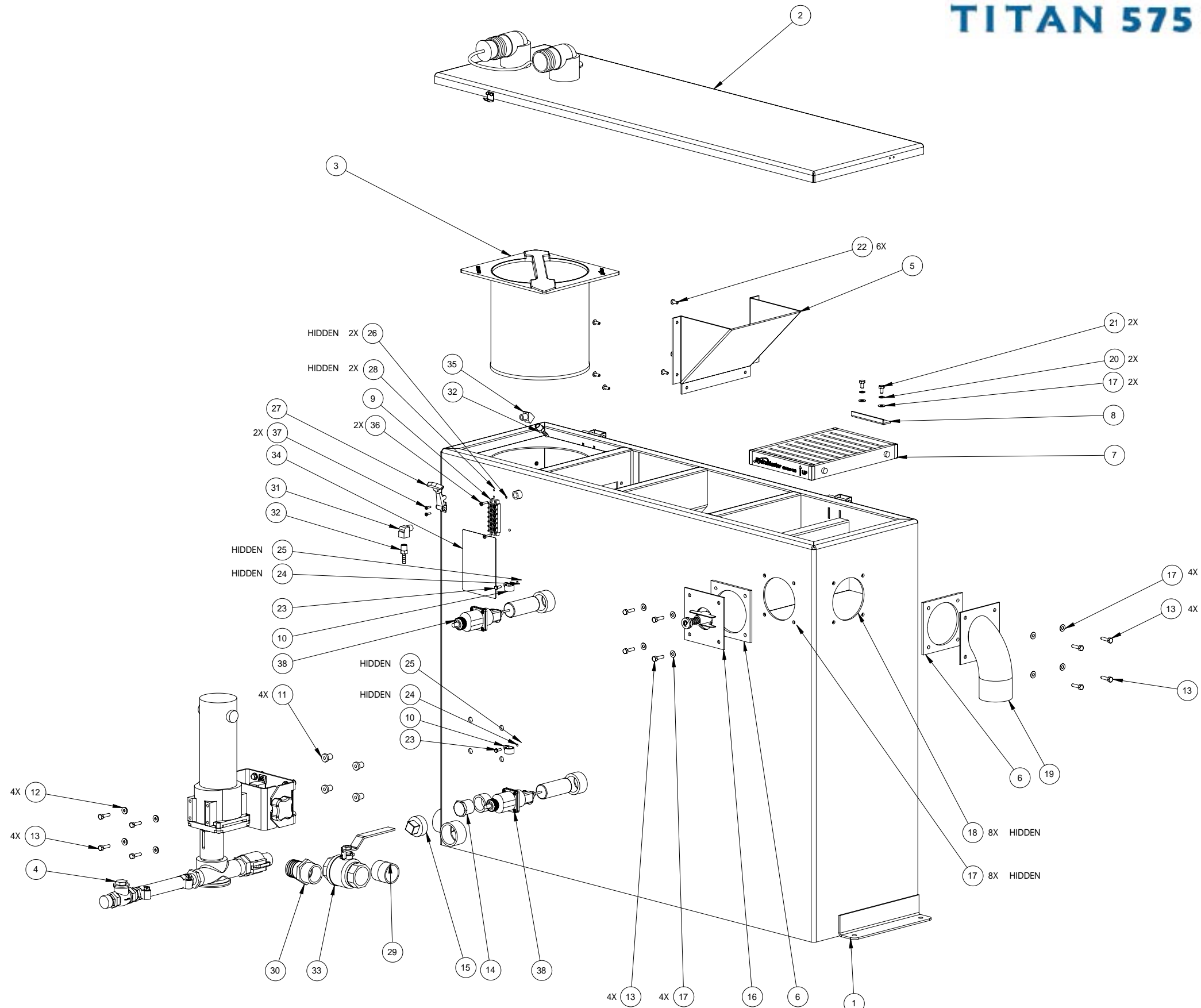
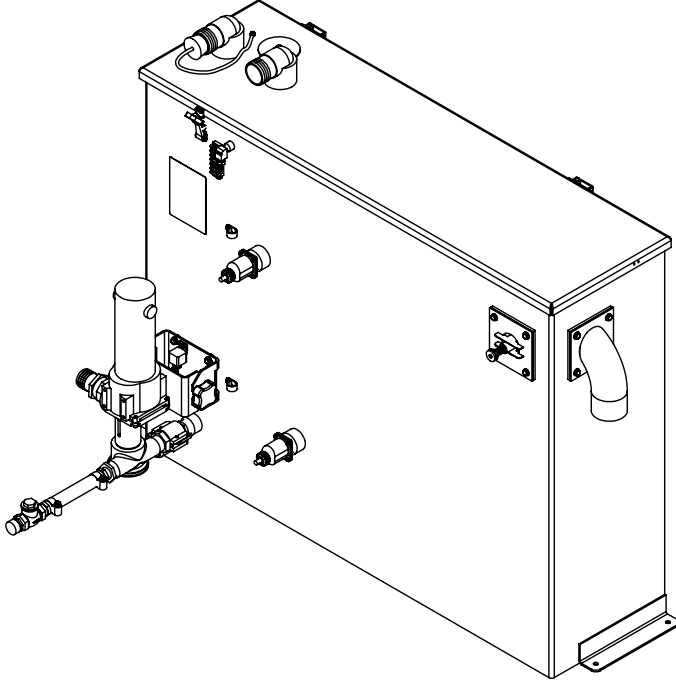

TITAN 575

100 Gallon Universal Recovery Tank Assembly Parts List

Item	Part Number	Description	Qty
1	000-159-129	100 Gallon URT	1
2	- -	Assembly, Recovery Tank Cover, with 2 1/2" Port	1
3	000-049-152	Filter, Recovery Tank Basket	1
4	000-079-091	Assembly, Dura-Flow APO - Production	1
5	000-049-154	Deflector, Air - URT	1
6	000-057-206	Gasket, Adapter - URT	2
7	000-049-153	Filter, Flat - URT	1
8	000-015-932	Bracket, Flat Filter Securing	1
9	000-012-002	Block, 6-Post Terminal	1
10	000-033-023	Clamp, 3/4" Nylon Hose	2
11	000-094-113	Nut, 1/4"-20UNC Neoprene Wellnut	4
12	000-174-060	Washer, 1/4" Rubber-Backed	4
13	000-143-002	Screw, 1/4"-20UNC X 1.00" Lg. Hex Head	12
14	000-106-049	Plug, 1" NPT Black Nylon	1
15	000-106-019	Plug, 1-1/2" NPT	1
16	601-050-001	Assembly, Vacuum Relief Valve - URT	1
17	000-174-003	Washer, 1/4" Flat	18
18	000-094-009	Nut, 1/4"-20UNC Nylock	8
19	000-001-135	Adapter, Tank to Ø3.0 X 90° Blower Hose	1

Item	Part Number	Description	Qty
20	000-174-019	Washer, 1/4" Lock	2
21	000-143-333	Screw, 1/4"-20UNC X 0.50" Lg. Hex Head	2
22	000-140-023	Rivet, AB8-6A Aluminum Pop	6
23	000-143-126	Screw, #10-24UNC X 0.50" Lg. Hex Head	2
24	000-174-036	Washer, #10 Flat Rubber-Backed	2
25	000-094-034	Nut, #10-24UNC Nylock	2
26	000-094-059	Nut, #8-32UNC Nylock	2
27	000-086-008	Latch, Bungee - Strike	1
28	000-094-063	Nut, #6-32UNC Nylock	2
29	000-052-763	Nipple, 1-1/2" IPS Close S/S	1
30	000-052-226	Insert, 1-1/2" NPT X 1-1/2" Barb (Gray)	1
31	000-052-085	Elbow, 1/4" NPT Street	1
32	000-052-100	Insert, #44	2
33	000-169-022	Valve, 1-1/2" Full Port Ball	1
34	- -	Label, Maintenance and Lube Schedule	1
35	000-052-082	Elbow, 1/4" NPT Street X 45°	1
36	000-143-051	Screw, #8-32UNC X 3/4" Lg. Binder Head	2
37	000-143-539	Screw, #6-32UNC X 0.50" Lg. Button Head	2
38	000-157-091	Float, Lever Switch	2

TITAN 575

Figure 9-38. 70 Gallon URT for 85 Gallon Rotomolded Tank Assembly - View 1 of 3 7456

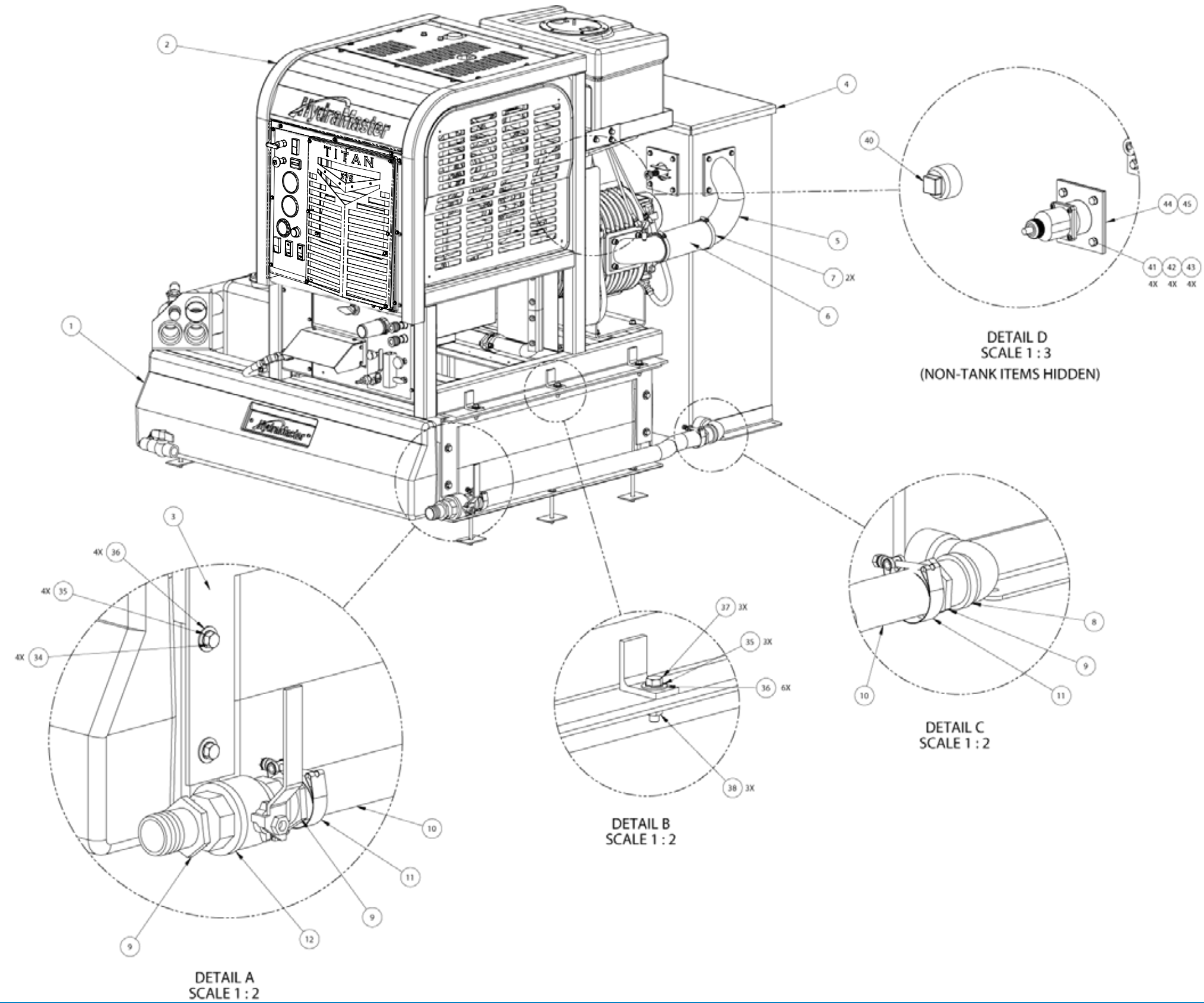

TITAN 575

Figure 9-39. 70 Gallon URT for
85 Gallon Rotomolded Tank
Assembly - View 2 of 3
7456

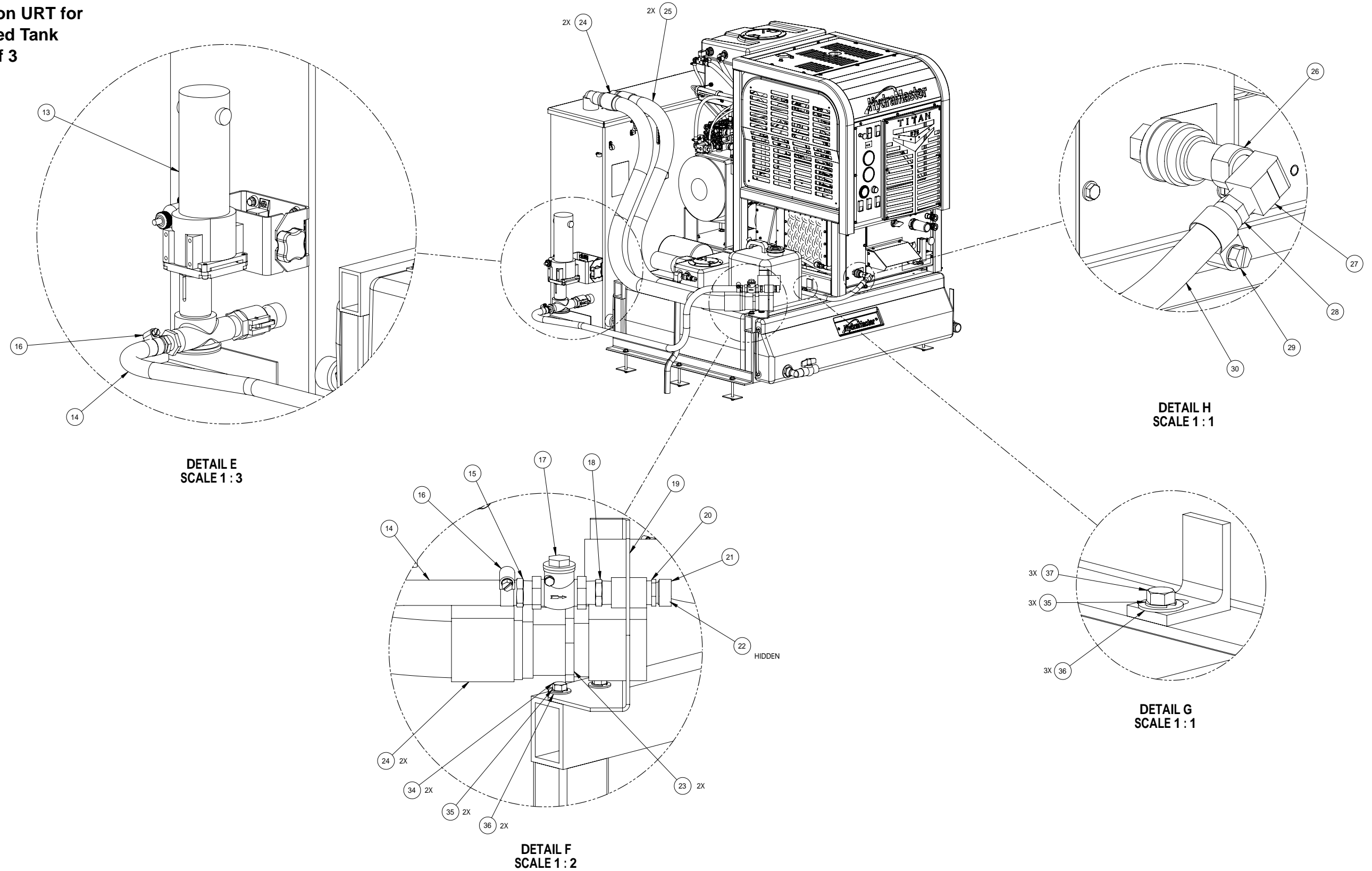
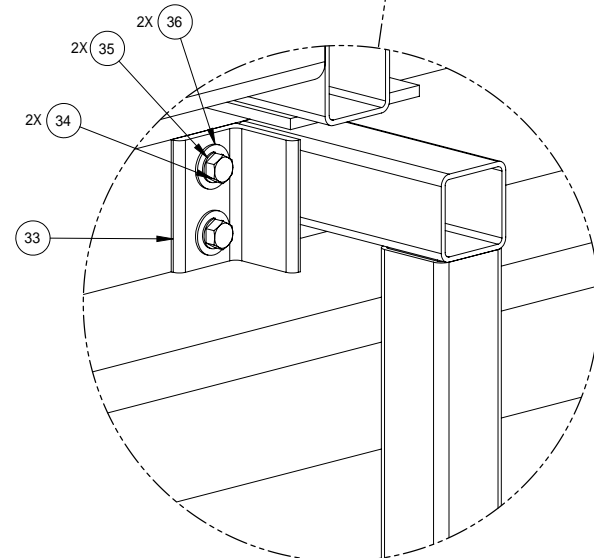
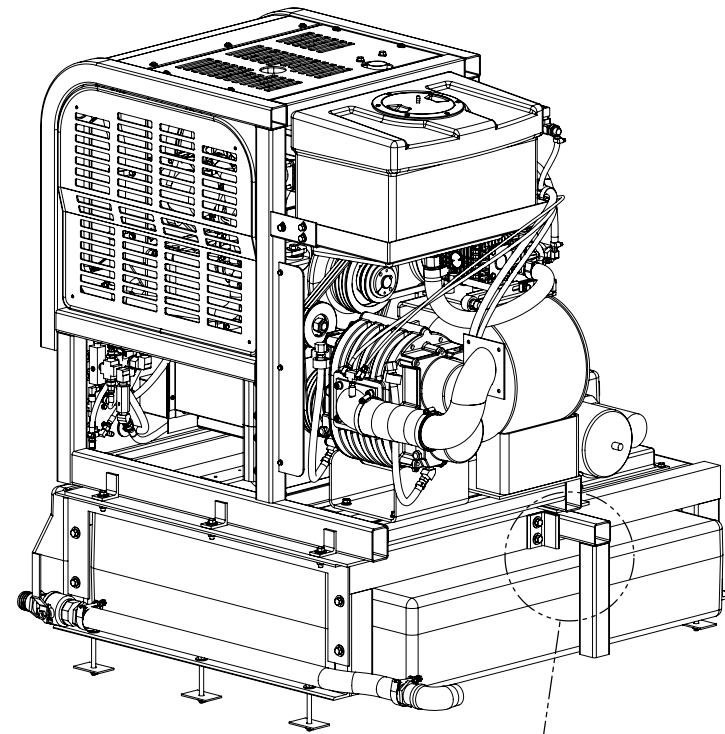
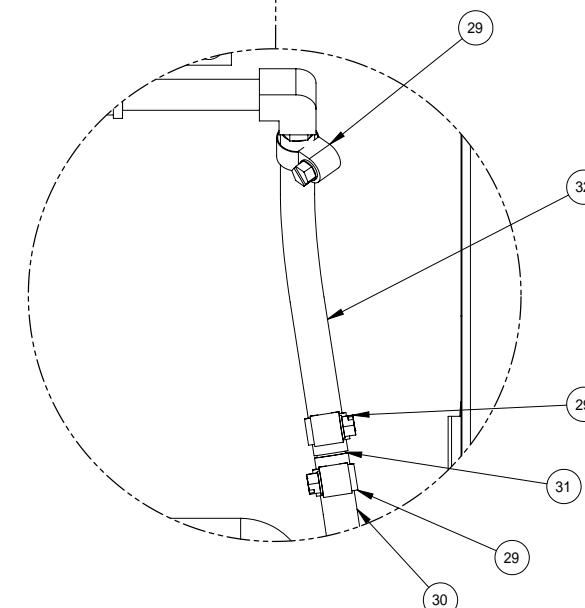
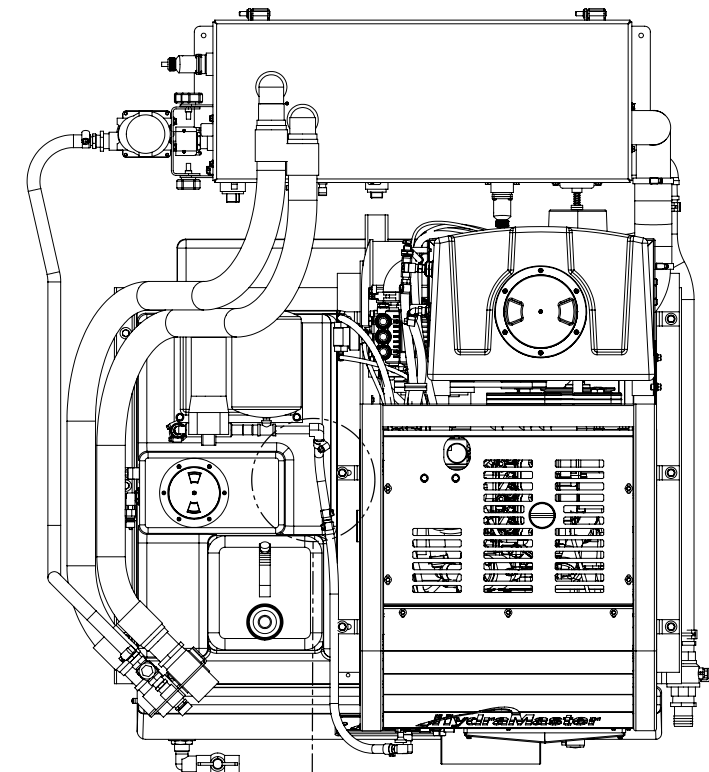

Figure 9-40. 70 Gallon URT for 85 Gallon Rotomolded Tank Assembly
- View 3 of 3
7456



DETAIL J
SCALE 1 : 2



DETAIL K
SCALE 1 : 2

TITAN 575

70 Gallon Universal Recovery Tank for 85 Gallon Rotomolded Tank Assembly Parts List

Item	Part Number	Description	Qty
1	000-159-118	Assembly, 85 Gallon Rotomolded Tank	1
2	610-050-575	Assembly, Machine - Titan 575	1
3	000-015-996	Rail, 85 RMT Frame Add-On	1
4	610-003-075	Assembly, 70 Gallon, URT	1
5	000-001-176	Adapter, Recovery Tank Inlet w/ 85 RMT	1
6	000-068-762	Hose, 3" X 12" Wire Reinforced Suction	1
7	000-033-013	Clamp, #48 Hose (3")	2
8	000-052-214	Elbow, 1-1/2" NPT Street	1
9	000-052-226	Insert, 1-1/2" NPT X 1-1/2" Barb (Gray)	3
10	000-068-135	Hose, 1 1/2", Red Stripe	4 ft
11	000-033-063	Clamp, 2" T-Bolt	2
12	000-169-022	Valve, 1-1/2" Full Port Ball	1
13	000-079-091	Assembly, Dura-Flow APO - Production	1
14	000-068-069	Hose, 3/4" Weatherhead Blue	1
15	000-052-338	Insert, #1212 (3/4" NPT X 3/4" Barb)	1
16	000-033-026	Clamp, Size #10	2
17	000-169-009	Valve, 3/4" FPT Swing Check	1
18	000-052-330	Nipple, 3/4" Brass, Hex	1
19	000-015-997	Bracket, Dump and Vacuum - 85 FWT - Weldment	1
20	000-052-281	Nipple, 3/4" NPT X 3/4" Male Garden Hose	1
21	000-027-014	Cap, Garden Hose	1
22	000-057-055	Washer, 80 Duro Neoprene	1

Item	Part Number	Description	Qty
23	000-052-221	Insert, 2" NPT X 2" Barb (Gray)	2
24	000-052-169	Cuff, Ø2" Vacuum Hose	4
25	000-068-039	Hose, 2" Gray Vacuum	12.5 ft
26	000-052-053	Quick Connect, 3/8 Female	1
27	000-052-086	Elbow, 3/8" NPT Street	1
28	000-052-105	Insert, #68 (3/8" NPT X 1/2" Barb)	1
29	000-033-004	Clamp, Size #6 Mini Hose	4
30	000-068-018	Hose 1/2"	1
31	000-052-120	Mender, 1/2" Brass Hose	1
32	000-068-327	Hose, 1/2" Clear Braided	1
33	000-015-995	Bracket, 5th Support Leg	1
34	000-143-017-1	Screw, 3/8"-16UNC X 3/4" Lg. Hex Head	8
35	000-174-057	Washer, 3/8" Lock	14
36	000-174-032	Washer, 3/8" Flat	17
37	000-143-020	Screw, 3/8"-16UNC X 1.50" Lg. Grd 5 Z/P	6
38	000-094-014	Nut, 3/8-16 Hex Z/P	3
40	000-106-046	Plug, 1-1/4" NPT	1
41	000-174-019	Washer, 1/4" Lock	4
42	000-143-001	Screw, 1/4"-20UNC X 0.75" Lg. Hex Head	4
43	000-094-009	Nut, 1/4"-20UNC Nylock	4
44	000-057-175	Gasket, Harwil Float	1
45	000-052-750	Fitting, Bulkhead - Harwil Float	1

Figure 9-41. 100 Gallon URT
for 85 Gallon Rotomolded Tank Assembly - View 1 of 3
7455

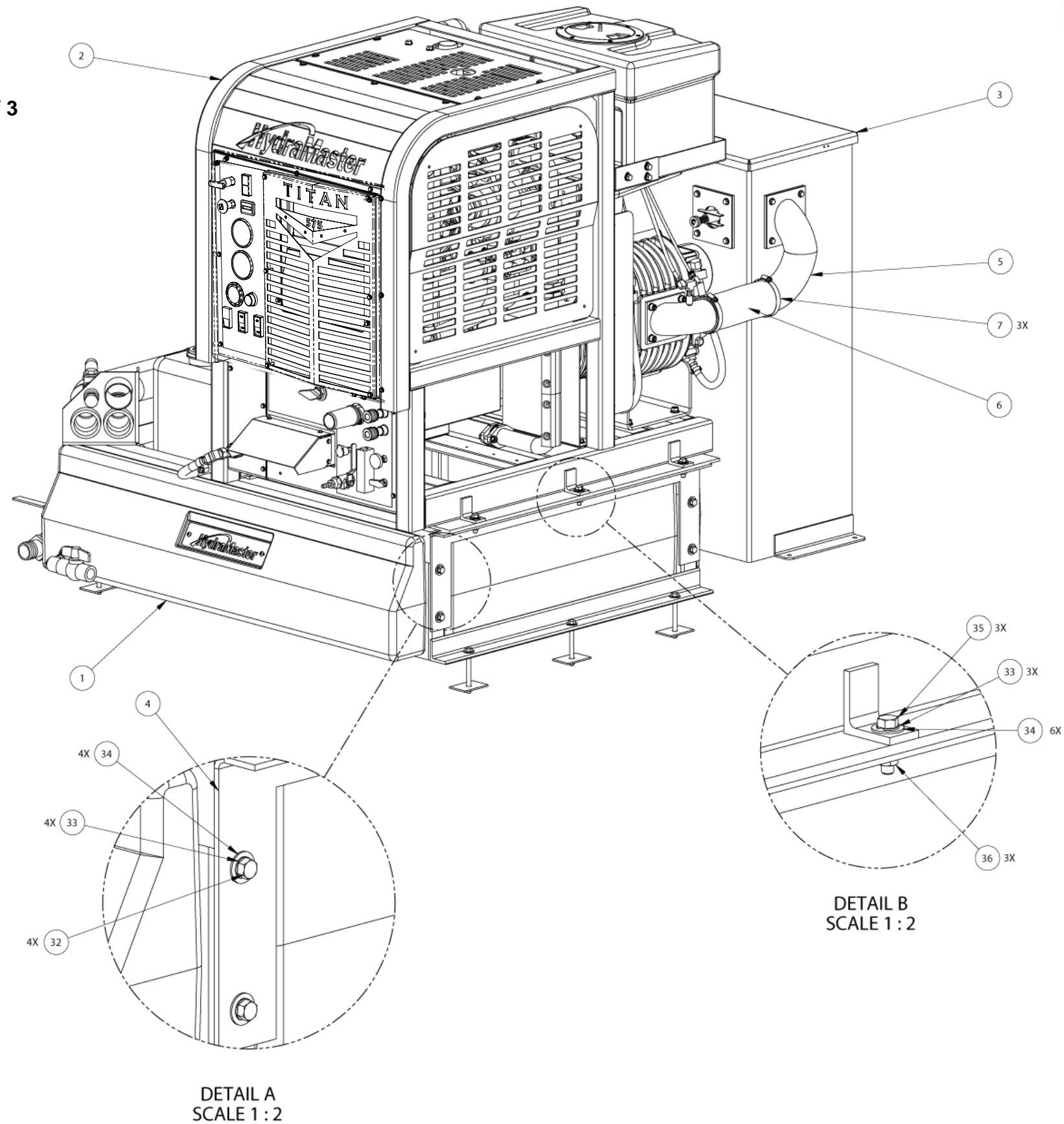

TITAN 575

Figure 9-42. 100 Gallon
URT for 85 Gallon
Rotomolded Tank
Assembly -
View 2 of 3
7455

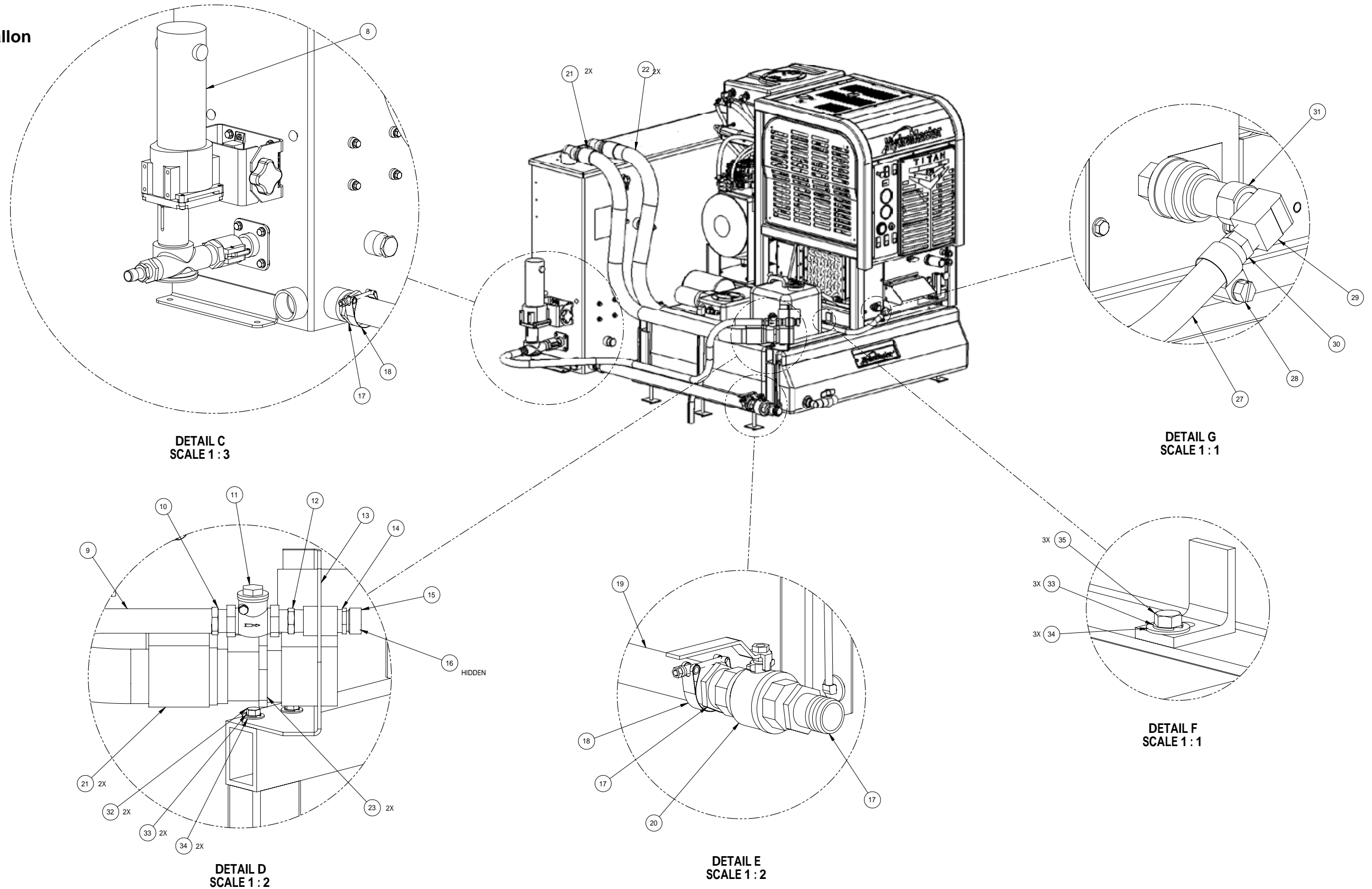
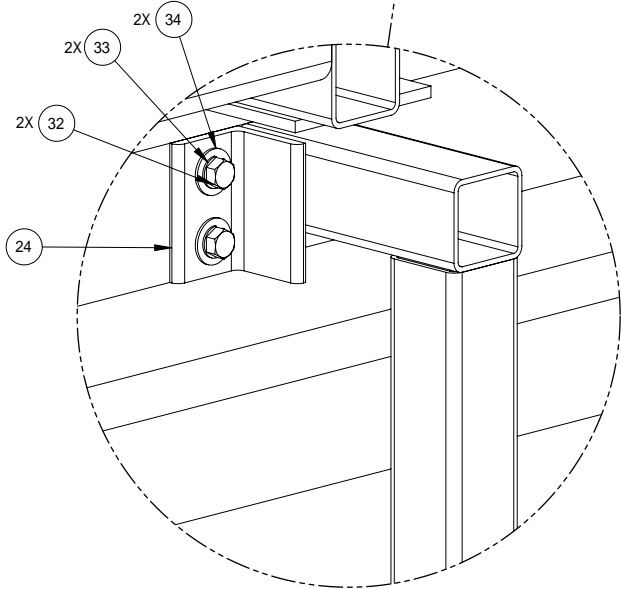
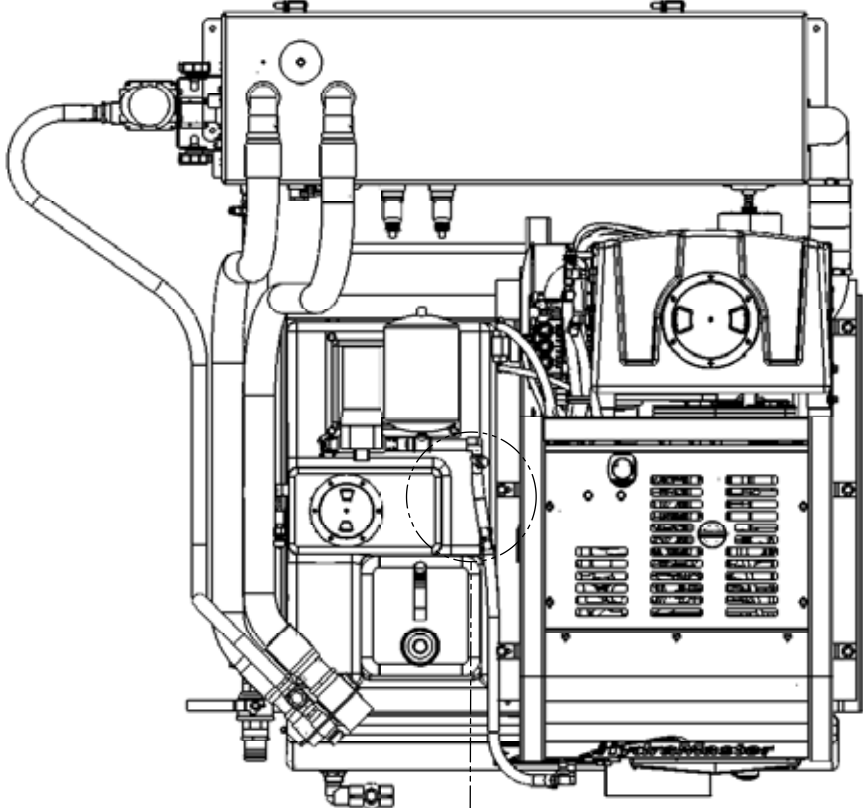
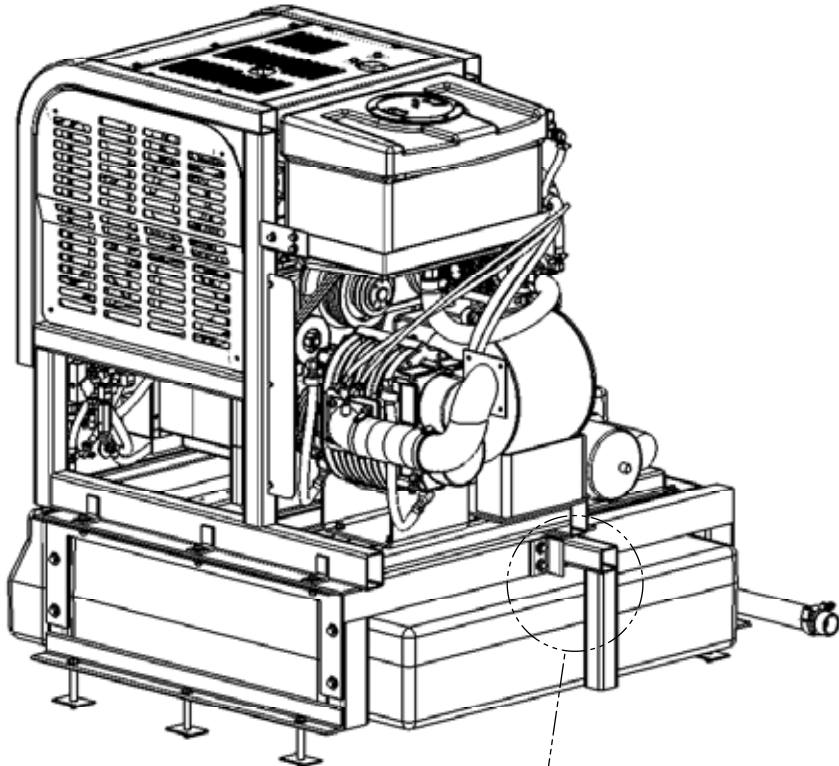
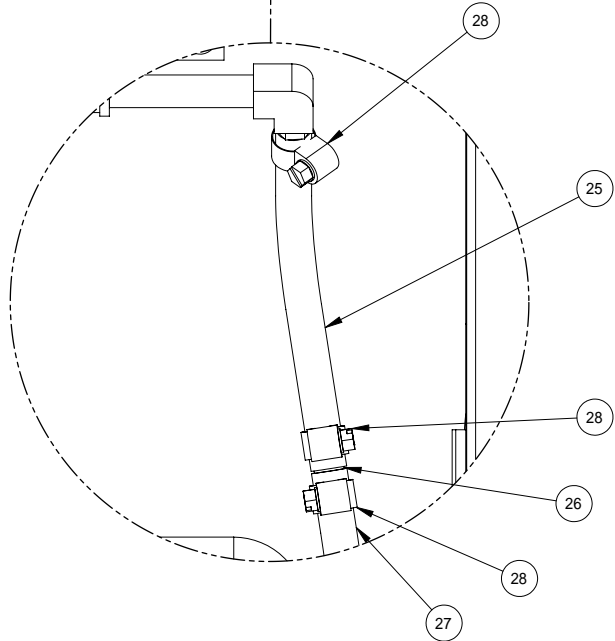

Figure 9-43. 100 Gallon URT
for 85 Gallon Rotomolded
Tank Assembly - View 3 of 3
7455



DETAIL H
SCALE 1 : 2



DETAIL J
SCALE 1 : 2

TITAN 575

100 Gallon URT for 85 Gallon Rotomolded Tank Assembly Parts List

Item	Part Number	Description	Qty
1	000-159-118	Assembly, 85 Gallon Rotomolded Tank (RMT)	1
2	610-050-575	Assembly, Machine - Titan 575	1
3	610-003-080	Assembly, 100 Gallon Recovery Tank	1
4	000-015-996	Rail, 85 RMT Frame Add-On	1
5	000-001-176	Adapter, Recovery Tank Inlet w/ 85 RMT	1
6	000-068-762	Hose, 3" X 12" Wire Reinforced Suction	1
7	000-033-013	Clamp, #48 Hose (3")	2
8	000-079-094	Assembly, Dura-Flow APO	1
9	000-068-069	Hose, 3/4" Weatherhead Blue	1
10	000-052-338	Insert, #1212 (3/4" NPT X 3/4" Barb)	1
11	000-169-009	Valve, 3/4" FPT Swing Check	1
12	000-052-330	Nipple, 3/4" Brass, Hex	1
13	000-015-997	Bracket, Dump and Vacuum - 85 FWT - Weldment	1
14	000-052-281	Nipple, 3/4" NPT X 3/4" Male Garden Hose	1
15	000-027-014	Cap, Garden Hose	1
16	000-057-055	Washer, 80 Duro Neoprene	1
17	000-052-226	Insert, 1-1/2" NPT X 1-1/2" Barb (Gray)	3
18	000-033-063	Clamp, 2" T-Bolt	2

Item	Part Number	Description	Qty
19	000-068-135	Hose, 1-1/2" Red Stripe	4 ft
20	000-169-022	Valve, 1-1/2" Full Port Ball	1
21	000-052-169	Cuff, Ø2" Vacuum Hose	4
22	000-068-039	Hose, 2" Gray Vacuum	1
23	000-052-221	Insert, 2" NPT X 2" Barb (Gray)	2
24	000-015-995	Bracket, 5th Support Leg	1
25	000-068-327	Hose, 1/2" Clear Braided	1
26	000-052-120	Mender, 1/2" Brass Hose	1
27	000-068-018	Hose 1/2"	1
28	000-033-004	Clamp, Size #6 Mini Hose	4
29	000-052-086	Elbow, 3/8" NPT Street	1
30	000-052-105	Insert, #68 (3/8" NPT X 1/2" Barb)	1
31	000-052-053	Quick Connect, 3/8 Female	1
32	000-143-017-1	Screw, 3/8"-16UNC X 3/4" Lg. Hex Head	8
33	000-174-057	Washer, 3/8" Lock	14
34	000-174-032	Washer, 3/8" Flat	17
35	000-143-020	Screw, 3/8"-16UNC X 1.50" Lg. Grd 5 Z/P	6
36	000-094-014	Nut, 3/8-16 Hex Z/P	3

Figure 9-44. High Pressure Washing Kit - Pump Assembly
7327 Rev. A

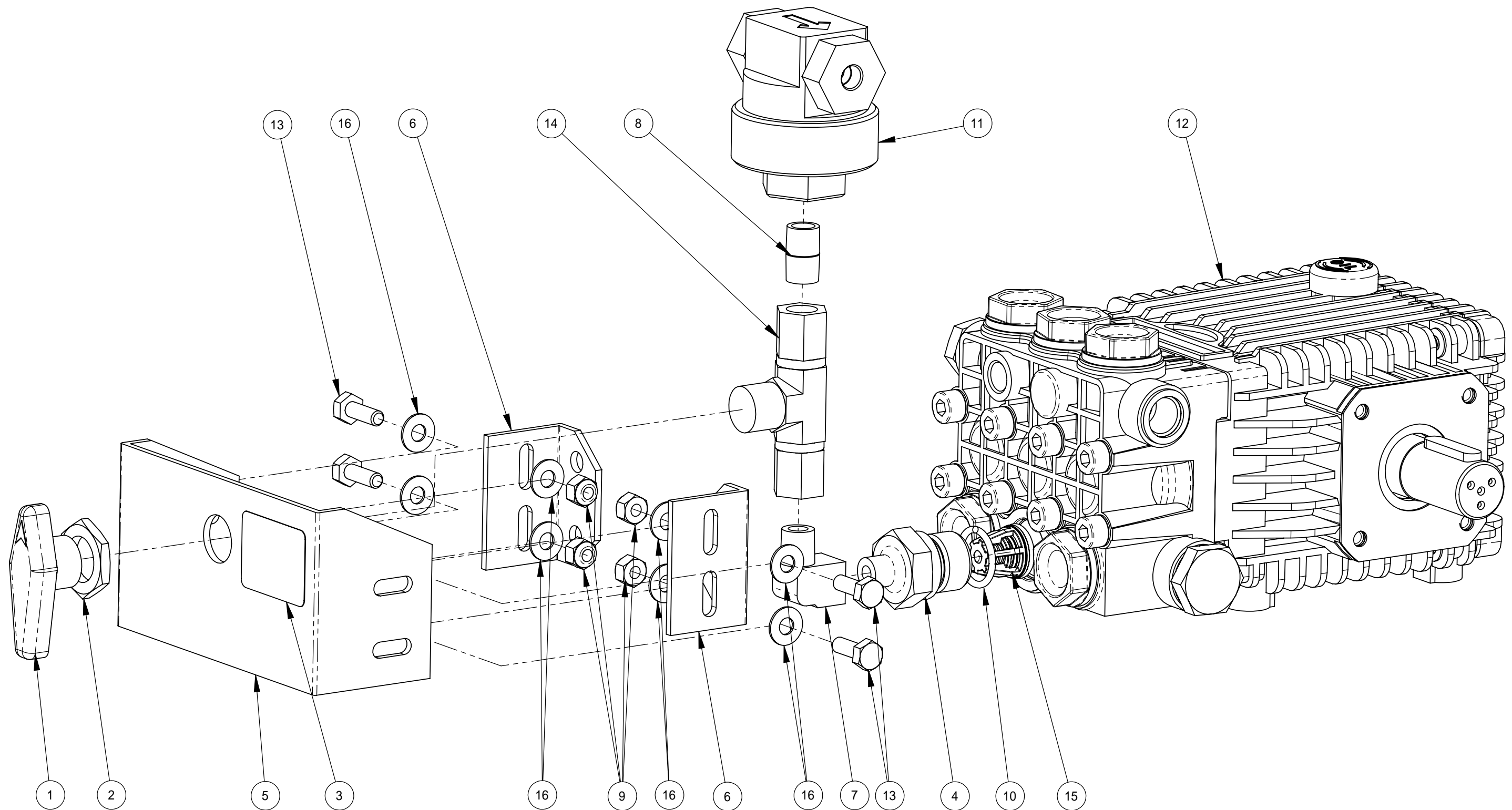

TITAN 575

High Pressure Washing Kit - Pump Assembly Parts List

Item	Part Number	Description	Qty
1	---	Handle, (Comes w/ 000-169-176)	1
2	---	Nut, (Comes w/ 000-169-176)	1
3	---	Label, Chemical Pump Shut Off	1
4	000-001-154	Adapter, GP to Chemical Pump S/S 4.0 Gallon	1
5	000-015-253	Bracket, Chemical Pump Main Support	1
6	000-015-254	Bracket, Chemical Pump Mount	2
7	000-052-085	Elbow, 1/4" NPT Street	1
8	000-052-517	Nipple, 1/4" NPT Close	1

Item	Part Number	Description	Qty
9	000-094-009	Nut, 1/4"-20UNC Nylock	4
10	000-097-057	O-Ring, Adapter - Chemical Pump	1
11	000-111-184	Pump, GP Chemical	1
12	000-111-188	Pump, 4.0 gpm GP	1
13	000-143-001	Screw, 1/4"-20UNC X 0.75" Lg. Hex Head	4
14	000-169-176	Valve, 2-Way Chemical Pump	1
15	000-169-221	Valve, GP Pump Check - Mod. - 4.0 Gallon	1
16	000-174-003	Washer, 1/4" Flat	8

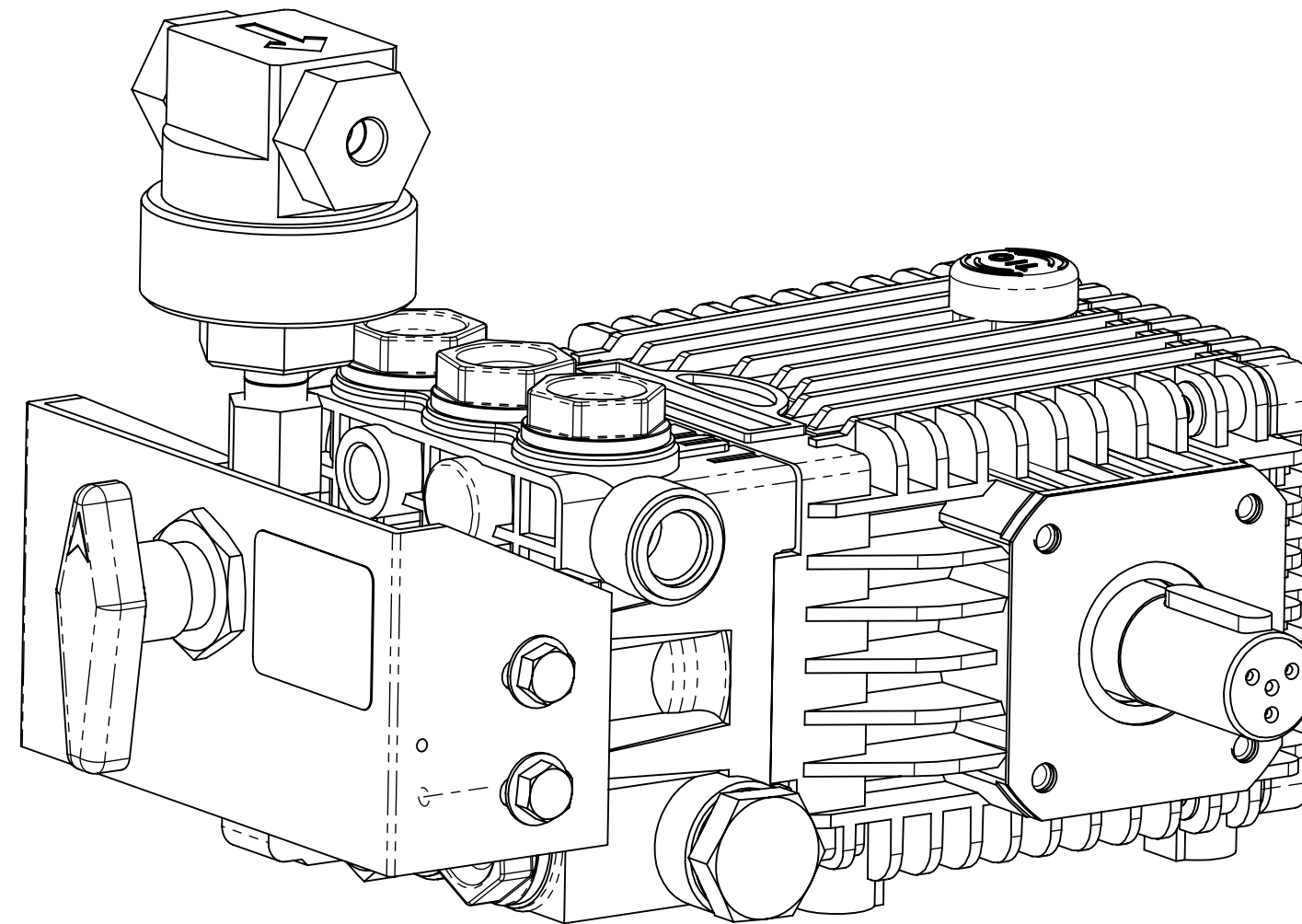
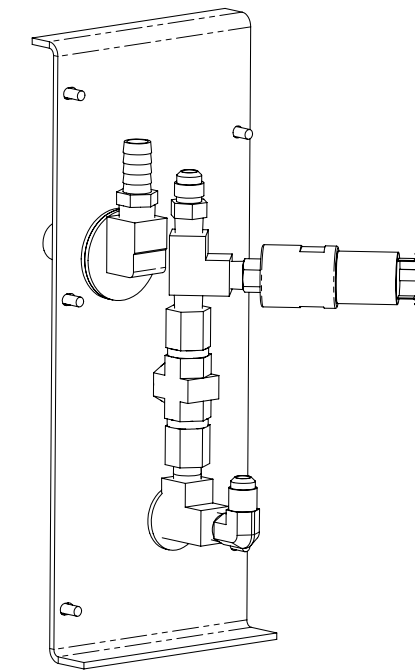
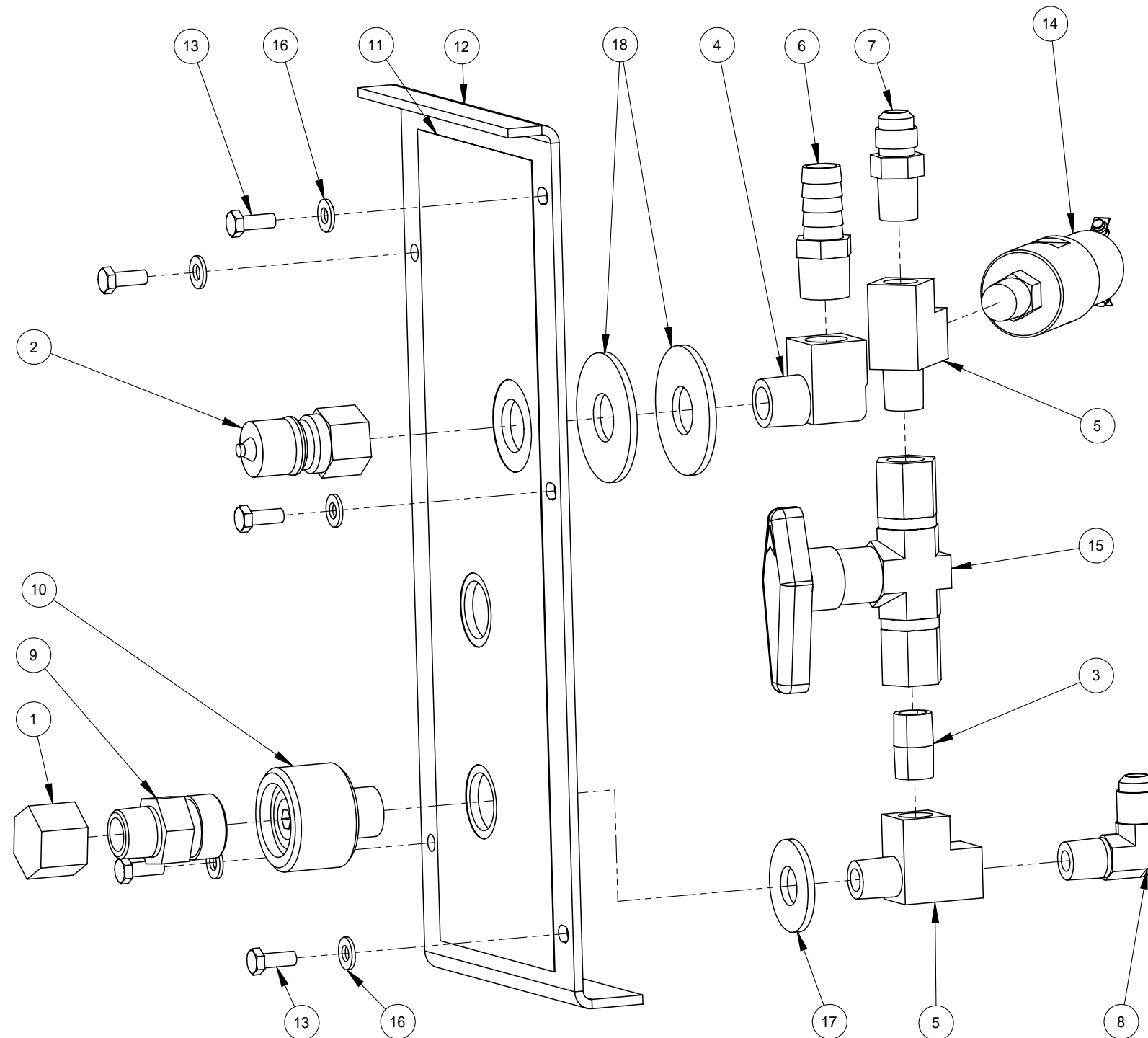

Figure 9-45. High Pressure Washing Kit - Lower Left Dash Assembly
7452 Rev. B



High Pressure Washing Kit - Lower Left Dash Assembly Parts List

Item	Part Number	Description	Qty
1	000-027-008	Cap, 3/8" Brass Pipe	1
2	000-052-052	Quick Connect, 660 3/8" Brass w/ EPDM O-Ring	1
3	000-052-072	Nipple, 1/4" NPT Close	1
4	000-052-086	Elbow, 3/8" NPT Street	1
5	000-052-090	Tee, 1/4" NPT Branch M-F-F	2
6	000-052-105	Insert, #68 (3/8" NPT X 1/2" Barb)	1
7	000-052-533	Nipple, 3/8" JIC X 1/4" NPT	1
8	000-052-751	Elbow, 3/8" JIC X 1/4" NPT	1
9	000-052-768	Quick Connect, High PSI Male 1/4" NPT	1
10	000-052-769	Quick Connect, High PSI Female 1/4" NPT	1
11	000-081-305	Label, Lower Dash - Left - Pressure Washing	1
12	000-100-188	Panel, Lower Dash - Left - Pressure Washing	1
13	000-143-126	Screw, #10-24UNC X 0.50" Lg. Hex Head	5
14	000-157-157	Switch, Nason 1,350 psi Shutoff	1
15	000-169-214	Valve, 2-Way Chemical Pump - 1/4" FPT S/S	1
16	000-174-001	Washer, #10 Flat	5
17	000-174-007	Washer, 1/2" Flat	1
18	000-174-008	Washer, 5/8" Flat	2

TITAN 575

Figure 9-46. Recovery Tank Cover with 2 1/2" Port Kit Assembly
7678

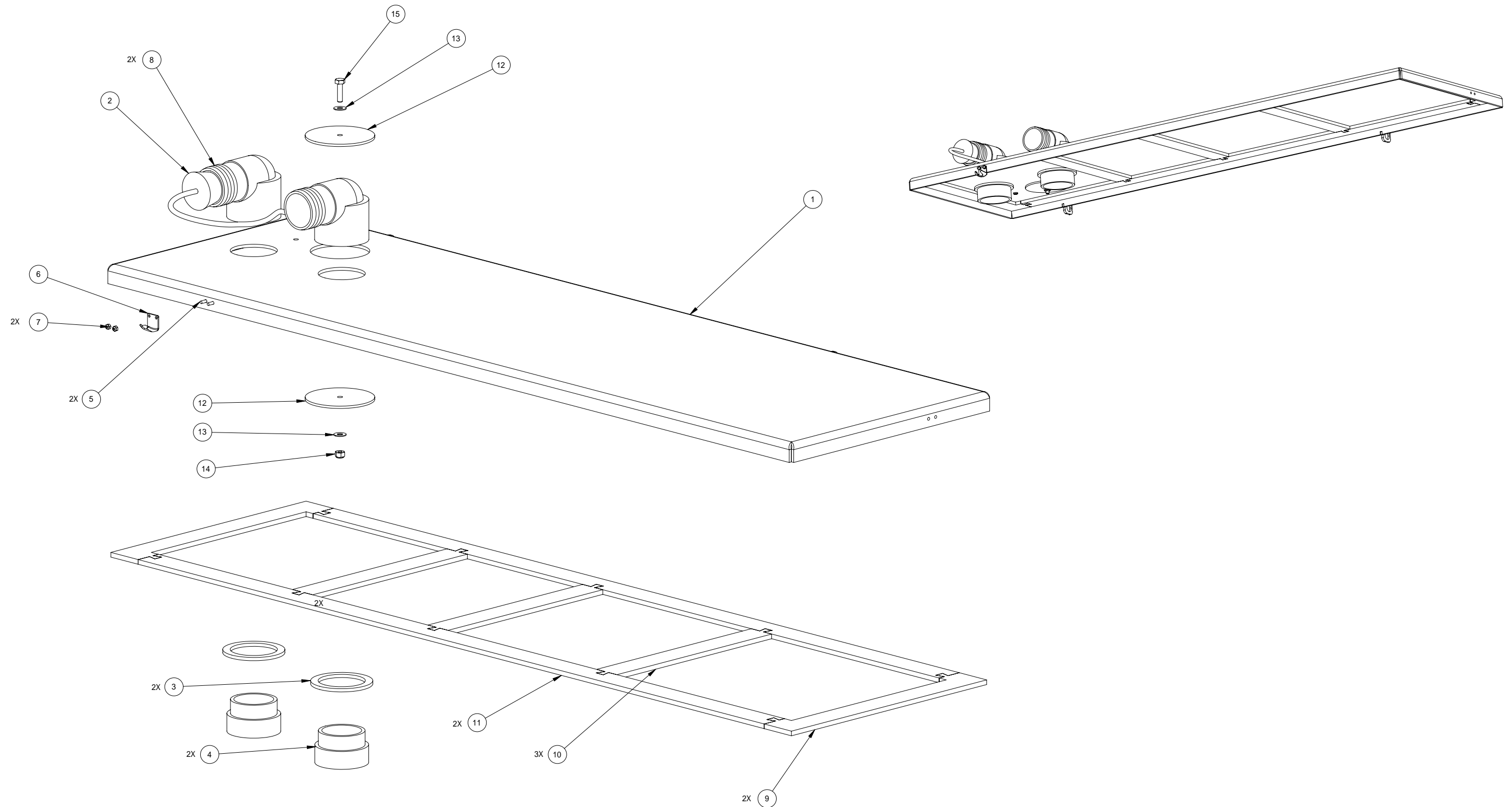

Recovery Tank Cover with 2 1/2" Port Kit Assembly Parts List

Item	Part Number	Description	Qty
1	000-041-465	Cover, Weldment - 100 URT	1
2	000-078-039	Assembly, Vacuum Inlet Stopper	1
3	000-057-015	Gasket, 1-1/2" Bulkhead Fitting	2
4	000-052-219	Adapter, 2" NPT X 2" F Slip	2
5	000-143-539	Screw, #6-32UNC X 0.50" Lg. Button Head	2
6	000-086-008	Latch, Bungee - Strike	1
7	000-094-063	Nut, #6-32UNC Nylock	2
8	000-052-222	Elbow, 2" Barb X 2" FPT	2

Item	Part Number	Description	Qty
9	000-057-202	Gasket, End - URT	2
10	000-057-203	Gasket, Middle - URT	3
11	000-057-205	Gasket, Side - URT	2
12	000-105-546	Plate, Ø3.50"	2
13	000-174-003	Washer, 1/4" Flat	2
14	000-094-009	Nut, 1/4"-20UNC Nylock	1
15	000-143-002	Screw, 1/4"-20UNC X 1.00" Lg. Hex Head	1

TITAN 575

Hose Routings

Part No.	Description	Overall Length	Hose Type	From	To
000-068-823	Hose, 3/16" X 38" w/JIC	38"	3/16 Teflon	Pressure Gauge	High Pressure Pump
000-068-822	Hose, 3/16" X 66" w/JIC	66"	3/16 Teflon	3-Way Chemical Valve (Mid Port)	Chemical Pump (Outlet)
000-068-821	Hose, 3/8" X 33" w/JIC	33"	3/8 Teflon	Solution Out (Differential Check Valve)	Blower Exchanger Outlet
000-068-820	Hose, 3/8" X 40" w/JIC	40"	3/8 Teflon	Heat Selector Valve (Left Hand Port)	Coolant Exchanger (Back)
000-068-791	Hose, 1" X 24" Lg Suction	24"	1" Inlet	High Pressure Pump Inlet	Water Box
000-068-790	Hose, 3/16" X 10.5" Teflon	10.5"	3/16 Teflon	Solution Out	Chemical Metering Valve (Top Port)
000-068-737	Hose, 3/8" X14.5" w/JIC	14.5"	3/8 Teflon	Heat Selector Valve (Left Hand Port)	Blower Exchanger Inlet (Front)
000-068-660	Hose, 1/4 Fuel Trident	8 ft	1/4 Fuel Hose	Carburetor	Out
000-068-641	Hose, 3/8" X 10" Teflon	10.5"	3/8 Teflon	Heat Selector Valve (Back Port)	By-Pass Valve (Top Port)
000-068-626	Hose, 3/8" X 28 1/2" T	28.5"	3/8 Teflon	Heat Selector Valve (Right Hand Port)	Coolant Exchanger (Front)
000-068-525	Hose, 3/8" X 54" Teflon	55.5"	3/8 Teflon	By-Pass Valve (Back Port)	High Pressure Pump (Outlet)
000-068-326	Hose, 3/8" Clr w/Braid	71"	3/8 Clear Braid	Chemical Flow Meter (Top)	Chemical Pump
000-068-030	Hose, 5/32" Rubber/Vac	10.6 ft	5/32 Vac Line	Vac Gauge	Blower [Cut Over Tee to Solenoid]
000-068-025	Hose, 1/4" Clear-Bulk	30"	1/4" Clear	Radiator Cap	Coolant Overflow Jug
000-068-018	Hose, 1/2" Rubber-Bulk	4.667 ft	1/2 Rubber	By-Pass Valve	Water Box
000-068-018	Hose, 1/2" Rubber-Bulk	5.125 ft	1/2 Rubber	Inlet Water QC	Water Box (Inlet Valve)
000-068-017	Hose, 3/8" Rubber-Bulk	13.5"	3/8 Rubber	Water Box Drain Valve (Backport)	By-Pass Valve
000-068-015	Hose, 1/4" Rubber-Bulk	77"	1/4 Rubber	3-Way Chemical Valve (Bottom Port)	Recovery Tank
000-068-015	Hose, 1/4" Rubber-Bulk	70"	1/4 Rubber	Water Box Tee	Recovery Tank
000-068-015	Hose, 1/4" Rubber-Bulk	4"	1/4 Rubber	Water Box Tee	Tee At Water Box

10 - How to Order Parts

To order warranty replacement parts or repairs, it is important that you read this section which includes:

- Warranty Parts Orders
- Parts Orders
- Emergencies

WARRANTY PARTS ORDERS

1. Call the local distributor where you purchased your equipment and ask for the Service Department.
2. Have the following information ready:
 - a. Equipment Model
 - b. Date of Purchase
 - c. Unit Serial Number
 - d. Description of Malfunction
3. Once it has been determined which parts are needed to correct the problem with your machine, make arrangements with your distributor to either perform the repairs or ship the parts to you.

Any questions you have regarding the warranty program should be directed to the Customer Service Department at (425) 775-7275, 7 a.m. to 5 p.m. Monday through Friday (PT).

We shall always endeavor to be fair in our evaluation of your warranty claim and shall provide you with a complete analysis of our findings.

HydraMaster warranty covers only defective materials and/or workmanship for the periods listed. Diagnostic reimbursement is specifically excluded.

PARTS ORDERS

Call your local distributor. In most instances, they either stock or have access to parts through a regional service center.

EMERGENCIES

If, for any reason, your distributor is unable to supply you with the necessary parts, they may call us and arrange for expedited shipping.

HydraMaster sells parts only through authorized distributors and service centers.

TITAN 575

11 - Warranty Information

To avoid misunderstandings which might occur between machine owners and the manufacturer, we are listing causes of component failure that specifically voids warranty coverage. Such causes listed in this section shall constitute abuse or neglect.

BLOWER

- Failure to lubricate impellers daily with a HydraMaster-recommended lubricant, to lubricate bearings, to maintain proper oil levels, or to use the correct oil grade and viscosity as recommended in blower manual.
- Failure to properly maintain blower safeguard systems such as waste tank filter screen, vacuum safety relief valve and waste tank automatic shut-off system.
- Allowing foam to pass through blower.

HIGH PRESSURE WATER PUMP

- Failure to maintain proper oil level as recommended in pump manual.
- Failure to change oil in pump at recommended intervals.
- Failure to protect pump against freezing.
- Failure to maintain pump protection shut-off system.
- Failure to use water softener in hard water areas.
- Use of improper chemicals.

VACUUM TANK

- Failure to properly maintain filtering devices in tank.
- Failure to clean tank as recommended by manufacturer.
- Failure to maintain vacuum safety release in tank.
- Use of improper chemicals.

CHEMICAL SYSTEM

- Use of improper chemical.
- Failure to use water softener in hard water area.
- Operating machine without proper chemical filter screen.
- Failure to protect against freezing.

CONTROL PANEL

- Failure to protect flowmeter and water pressure gauge against freezing.

TITAN 575

VACUUM AND SOLUTION HOSES

- Failure to protect hoses against freezing.
- Failure to protect hoses against burns from engine and blower exhaust.
- Damage to hoses from being run over by vehicles.
- Kinking or cracking from failure to store or unroll hoses correctly.
- Normal wear and tear from everyday use.

CLEANING WAND AND TOOL

- Failure to protect against freezing.
- Obvious physical abuse of wand or tool.

WATER HEATING SYSTEM

- Over-pressurization of the system (recommended maximum working pressure - 1,200 psi).
- Failure to protect against freezing.

HARD WATER DEPOSITS

- Failure to use or maintain a water softening system or a properly installed magnetic-type descaler, whichever might be necessary, with machines operating in designated "Hard Water Areas" (3.0 grains or more per gallon).

WARRANTY PROCEDURE

Warranty coverage is available to you through your local distributor. Please refer to the Golden Guarantee© Limited Warranty document shipped to you with the Owner's Guide. (You can also refer to <http://www.hydramaster.com/KnowledgeCenter/Warranty.aspx>).

If you have moved to a new area or have purchased a used machine and need information regarding your local distributor, call HydraMaster at (425) 775-7272 or email us at: techsupport@hydramaster.com.

When calling your distributor, be sure to have the machine's information; model and serial number, ready for the service representative.

12 - Accessories and Chemical Solutions

HydraMaster's machine accessories are the most innovative collection available in the cleaning industry. For example, our RX-20 Rotary Extractors have changed the shape of steam cleaning. In addition, our hoses, reels and tanks are of the finest quality construction.

Our carpet care and hard floor care chemical solutions have been specially prepared, not only to give you exceptional cleaning, but also to optimize your truckmount's operation and reliability. HydraMaster's chemical solutions will help maintain your machine's water pump and water heating systems at peak efficiency and also help ensure fewer breakdowns.

HydraMaster's full line of machine accessories and chemicals can enhance cleaning performance while reducing your labor costs, and include:

- Upholstery Tools
- Wands
- Vacuum Hoses
- Tanks
- Van Accessories
- Hose Reels
- Carpet Care Detergents
- Rinse Agents
- Pre-Sprays
- Hard Floor Care Detergents
- De-Foamers and Descalers
- Deodorizers and Disinfectants
- Spotting Agents

For more information about our full line of accessories and chemical solutions, refer to the HydraMaster website at <http://www.hydramaster.com>.

To order genuine HydraMaster accessories and chemical solutions, call your nearest authorized HydraMaster Distributor.

TITAN 575