



Titan 575

Owner's Manual

HydraMaster
11015 47th Avenue West
Mukilteo, Washington 98275

MAN-47792 REV B. January 2021
(P/N: 000-182-305)

No part of this manual may be reproduced or used in any form or by any means (i.e. graphic, electronic, photocopying or electronic retrieval systems) without the express written permission of HydraMaster. Specifications and information in this document are subject to change without prior notice. All rights reserved. © 2021 HydraMaster

TITAN 575

Table of Contents

GENERAL INFORMATION	SECTION 1
System Concept.....	1-3
Contact Information.....	1-4
Warnings, Cautions and Notices	1-5
Responsibilities	1-9
Machine Specifications	1-12
Spare Parts	1-14
High Altitude Operation	1-15
Local Water Precautions	1-15
INSTALLATION INFORMATION	SECTION 2
Operating the Titan 575 in Hot Weather.....	2-2
Setting Up the Titan 575.....	2-5
Orientation of Fuel Pump	2-6
CLEANING AND CHEMICALS	SECTION 3
Precautions	3-1
Preparing the Carpet for Extraction.....	3-2
Rinse and Recover.....	3-2
Overwetting.....	3-3
Streaking.....	3-3
Cleaning Tool Tips.....	3-4
OPERATING INSTRUCTIONS	SECTION 4
Setting the Temperature.....	4-3
Start Up Procedure	4-4
Setting the Pressure (for Optional High Pressure Washing Kit).....	4-5
Shut Down Procedure	4-6
MACHINE MAINTENANCE	SECTION 5
Operational Maintenance	5-2
Overall Machine Maintenance.....	5-4
Engine Maintenance	5-5
High Pressure Pump Maintenance	5-8
Vacuum System Maintenance	5-17
Descaling Procedure (Required).....	5-18
Freeze Guarding	5-19
WATER AND CHEMICAL SYSTEM	SECTION 6

TITAN 575

ELECTRICAL SYSTEM.....	SECTION 7
Electrical System Information.....	7-1
SYSTEMS TROUBLESHOOTING	SECTION 8
Heating System.....	8-2
Chemical System	8-3
Engine	8-4
High Pressure System	8-8
Vacuum System	8-10
ASSEMBLIES AND PARTS LISTS.....	SECTION 9
Console Assembly Parts List.....	9-7
Frame Assembly Parts List	9-9
Engine Assembly Parts List.....	9-14
Exhaust Assembly Parts List.....	9-15
Top Cover Assembly Parts List	9-16
Flywheel Plate Assembly Parts List	9-18
Upper Dash Assembly Parts List.....	9-20
Electrical Panel Assembly Parts List.....	9-23
Blower Assembly Parts List.....	9-25
Pump and Silencer Assembly Parts List	9-26
Pump Assembly Parts List	9-29
Water Box Assembly Parts List	9-31
Diffuser Assembly Parts List	9-32
Lower Dash Assembly Parts List.....	9-35
Side Cover Assembly Parts List.....	9-36
Blower Heat Exchanger Assembly Parts List.....	9-39
Coolant Heat Exchanger Assembly Parts List.....	9-41
Diverter Valve Box Assembly Parts List	9-42
Chemical Jug Tray/Hose/Connection Package Parts List.....	9-43
Chemical Jug Tray Assembly Parts List	9-44
By-Pass Valve Assembly Parts List.....	9-46
3-Way Valve Assembly Parts List.....	9-47
Actuator Valve Assembly Parts List.....	9-48

TITAN 575

Hi Pressure Manifold Assembly Parts List	9-49
Differential Check Valve Assembly Parts List.....	9-50
70 Gallon Universal Recovery Tank (URT) Assembly Parts List.....	9-51
70 Gallon Universal Recovery Tank (URT) Cover Assembly Parts List	9-54
100 Gallon Universal Recovery Tank (URT) Assembly Parts List.....	9-56
100 Gallon Universal Recovery Tank (URT) Cover Assembly Parts List	9-58
Vacuum Relief Valve Assembly Parts List.....	9-59
Vacuum Inlet Stopper Assembly Parts List	9-60
AWDS Universal Kit Assembly Parts List.....	9-62
High Pressure Washing Kit - Pump Assembly Parts List	9-64
High Pressure Washing Kit - Lower Left Dash Assembly Parts List	9-65
Sacrificial Anode Assembly Parts List.....	9-66

HOW TO ORDER PARTS SECTION 10

Warranty Parts Orders	10-1
Parts Orders.....	10-1
Emergencies	10-1

WARRANTY INFORMATION..... SECTION 11

Blower	11-1
High Pressure Water Pump	11-1
Recovery Tank	11-1
Chemical System	11-1
Control Panel	11-1
Vacuum and Solution Hoses	11-2
Cleaning Wand and Tool	11-2
Water Heating System	11-2
Hard Water Deposits.....	11-2
Warranty Procedure	11-2

ACCESSORIES AND CHEMICAL SOLUTIONS SECTION 12

List of Figures

Figure 1-1. Hard Water Map of Mainland United States	1-16
Figure 2-1. Location of Roof Vents in Vehicle	2-1
Figure 2-2. Recommended Location of Titan 575 in Van	2-3
Figure 2-3. Install Fuel Pump, Outlet Side Up.....	2-6
Figure 2-4. Fuel Pump Must Be in Vertical Position.....	2-6
Figure 4-1. Titan 575 Upper Dash Assembly	4-1
Figure 4-2. Titan 575 Lower Dash Assembly	4-2
Figure 4-3. Temperature Control Dial.....	4-3
Figure 4-4. Location of Chemical System Switches.....	4-5
Figure 4-5. Location of Blower Lube Port.....	4-6
Figure 5-1. Remove Valve Cap and Valve Assembly	5-9
Figure 5-2. Inspect Manifold and Old Valves	5-9
Figure 5-3. Replace Center Inlet Check Valve With Modified Check Valve	5-10
Figure 5-4. Apply Grease and Install Valves	5-10
Figure 5-5. Replace Valve Cap and Torque to 95 ft. lbs.	5-10
Figure 5-6. Separate Manifold from Crankcase	5-11
Figure 5-7. Seal Assemblies May Come Off with Manifold	5-11
Figure 5-8. Examine Ceramic Plungers	5-11
Figure 5-9. Remove Stainless Steel Plunger Bolt and Ceramic Plunger	5-12
Figure 5-10. Install O-ring, Apply Sealant and Slide Plunger over Plunger Guide	5-12
Figure 5-11. Extract Retainers and Seals	5-13
Figure 5-12. Seal Kit and Insertion Tool for Seal Installation	5-14
Figure 5-13. Install Seal Assembly Using O-Ring Grease	5-14
Figure 5-14. Install Retainers into Cavities	5-15
Figure 5-15. Press Low Pressure Seal Assembly into Cavity	5-15
Figure 5-16. Re-install Manifold and Torque Fasteners	5-16
Figure 5-17. Torque Sequence in "X" Pattern	5-16
Figure 5-18. Torque Bolts to 22 ft. lbs	5-16
Figure 5-19. Recirculation Fitting	5-18
Figure 6-1. Annotated Water, Chemical and Solution Flow Diagram - View 1 of 3	6-3
Figure 6-2. Annotated Water, Chemical and Solution Flow Diagram - View 2 of 3	6-4
Figure 6-3. Annotated Water, Chemical and Solution Flow Diagram - View 3 of 3	6-5
Figure 6-4. Water, Chemical and Solution Flow Diagram - Larger View	6-6
Figure 6-5. Chemical Flow Diagram - Larger View	6-7
Figure 6-6. Exhaust Flow Diagram.....	6-8

TITAN 575

Figure 7-1. Electrical Schematic	7-2
Figure 7-2. Wiring Diagram - View 1 of 3	7-3
Figure 7-3. Wiring Diagram - View 2 of 3	7-4
Figure 7-4. Wiring Diagram - View 3 of 3	7-5
Figure 9-1. Adhesive/ Material Reference	9-2
Figure 9-2. Console Assembly - View 1 of 4	9-3
Figure 9-3. Console Assembly - View 2 of 4	9-4
Figure 9-4. Console Assembly - View 3 of 4	9-5
Figure 9-5. Console Assembly - View 4 of 4	9-6
Figure 9-6. Frame Assembly	9-8
Figure 9-7. Engine Assembly - View 1 of 4	9-10
Figure 9-8. Engine Assembly - View 2 of 4	9-11
Figure 9-9. Engine Assembly - View 3 of 4	9-12
Figure 9-10. Engine Assembly - View 4 of 4	9-13
Figure 9-11. Exhaust Assembly	9-15
Figure 9-12. Top Cover Assembly	9-16
Figure 9-13. Flywheel Plate Assembly	9-17
Figure 9-14. Upper Dash Assembly	9-19
Figure 9-15. Electrical Panel Assembly - View 1 of 2	9-21
Figure 9-16. Electrical Panel Assembly - View 2 of 2	9-22
Figure 9-17. Blower Assembly	9-24
Figure 9-18. Pump and Silencer Assembly	9-26
Figure 9-19. Pump Assembly - View 1 of 2	9-27
Figure 9-20. Pump Assembly - View 2 of 2	9-28
Figure 9-21. Water Box Assembly	9-30
Figure 9-22. Diffuser Filter Assembly	9-32
Figure 9-23. Lower Dash Assembly - View 1 of 2	9-33
Figure 9-24. Lower Dash Assembly - View 2 of 2	9-34
Figure 9-25. Side Cover - Console Assembly	9-36
Figure 9-26. Blower Heat Exchanger Assembly - View 1 of 2	9-37
Figure 9-27. Blower Heat Exchanger Assembly - View 2 of 2	9-38
Figure 9-28. Coolant Heat Exchanger Assembly - View 1 of 2	9-40
Figure 9-29. Coolant Heat Exchanger Assembly- View 2 of 2	9-41
Figure 9-30. Diverter Valve Assembly	9-42
Figure 9-31. Chemical Jug Tray/Hose/Connection Package	9-43
Figure 9-32. Chemical Jug Tray Assembly	9-44
Figure 9-33. By-Pass Valve Assembly - View 1 of 2	9-45
Figure 9-34. By-Pass Valve Assembly - View 2 of 2	9-46
Figure 9-35. 3-Way Valve Assembly	9-47

TITAN 575

Figure 9-36. Actuator Valve Assembly	9-48
Figure 9-37. Hi Pressure Manifold Assembly	9-49
Figure 9-38. Differential Check Valve Assembly	9-50
Figure 9-39. 70 Gallon Universal Recovery Tank (URT) Assembly.....	9-51
Figure 9-40. 70 Gallon Universal Recovery Tank (URT) Cover Assembly	9-53
Figure 9-41. 100 Gallon Universal Recovery Tank (URT) Assembly.....	9-55
Figure 9-42. 100 Gallon Universal Recovery Tank (URT) Cover Assembly	9-57
Figure 9-43. Vacuum Relief Valve Assembly.....	9-59
Figure 9-44. Vacuum Inlet Stopper Assembly	9-60
Figure 9-45. AWDS Universal Kit Assembly.....	9-61
Figure 9-46. High Pressure Washing Kit - Pump Assembly	9-63
Figure 9-47. High Pressure Washing Kit - Lower Left Dash Assembly	9-65
Figure 9-48. Sacrificial Anode Assembly	9-66

TITAN™ 575

1- General Information

The compact but powerful Titan™ 575 is a carefully engineered truckmount carpet cleaning machine designed and manufactured by HydraMaster. A WG 972 Kubota engine powers the 575's Tuthill 4007 Tri-Lobe vacuum blower and the high pressure water pump, which is rated at 4 gpm.



The Titan 575's innovative design features include a blower/engine exhaust diverter which allows for a non-recirculating or “dump-less” subsystem.* This dump-less system, a first in the carpet cleaning industry, reduces the need to refill the fresh water tank or empty the recovery tank.

* Patented Heat Exchanger System - U.S. Patent No. 8,032,979

TITAN 575

Other features of the Titan 575 are:

- Dual oil bath and sight glasses for enhanced blower reliability
- 0 - 1,200 psi heated for carpet and tile cleaning
- Optional 2,000 psi pressure washing kit
- Dual tool/wand capable
- A.D.C temperature control with instant heat up to 265 Degrees F
- Optional Automatic Wastewater Disposal System (AWDS)
- Optional 85 gallon Fresh Water Tank Mounting Kit

The Titan 575 can be mounted onto a HydraMaster 85 gallon Rotomolded Fresh Water Tank. You can also select either the HydraMaster 70 gallon recovery tank, which comes in the standard equipment package, or a 100 gallon recovery tank, offered as an option.

This Owner's Manual contains installation and operation instructions as well as information required for proper maintenance, adjustment and repair of the Titan 575. Component troubleshooting guides have also been included for your convenience.

It is the purpose of this manual to help you properly understand, maintain and service your Titan 575. Follow the directions carefully and you will be rewarded with years of profitable, trouble-free operation.

It is imperative that no section of this manual be overlooked when preparing for operation of the Titan 575. Please read the manual to familiarize yourself with the operation of your Titan 575, paying special attention to all **Warnings and Cautions**.

This section of the manual contains the following information:

- System Concept
- Contact Information
- Warnings, Cautions and Notices
- Responsibilities
- Machine Specifications
- Spare Parts
- High Altitude Operation
- Local Water Precautions

NOTICE

Photographs and illustrations included in this document can represent optional equipment as well as standard equipment.

TITAN 575

SYSTEM CONCEPT

This is how the Titan 575 works:

1. Incoming water enters the water box and is pressurized by the high pressure water pump. The water is heated by engine coolant in the coolant heat exchanger and then by the engine and blower exhaust in the cross flow heat exchanger.
2. Cleaning solution is then injected into the pressurized water stream and the heated solution is delivered to the cleaning tool.
3. The solution is recovered by the vacuum generated by the vacuum pump and is collected in the recovery tank for proper disposal.

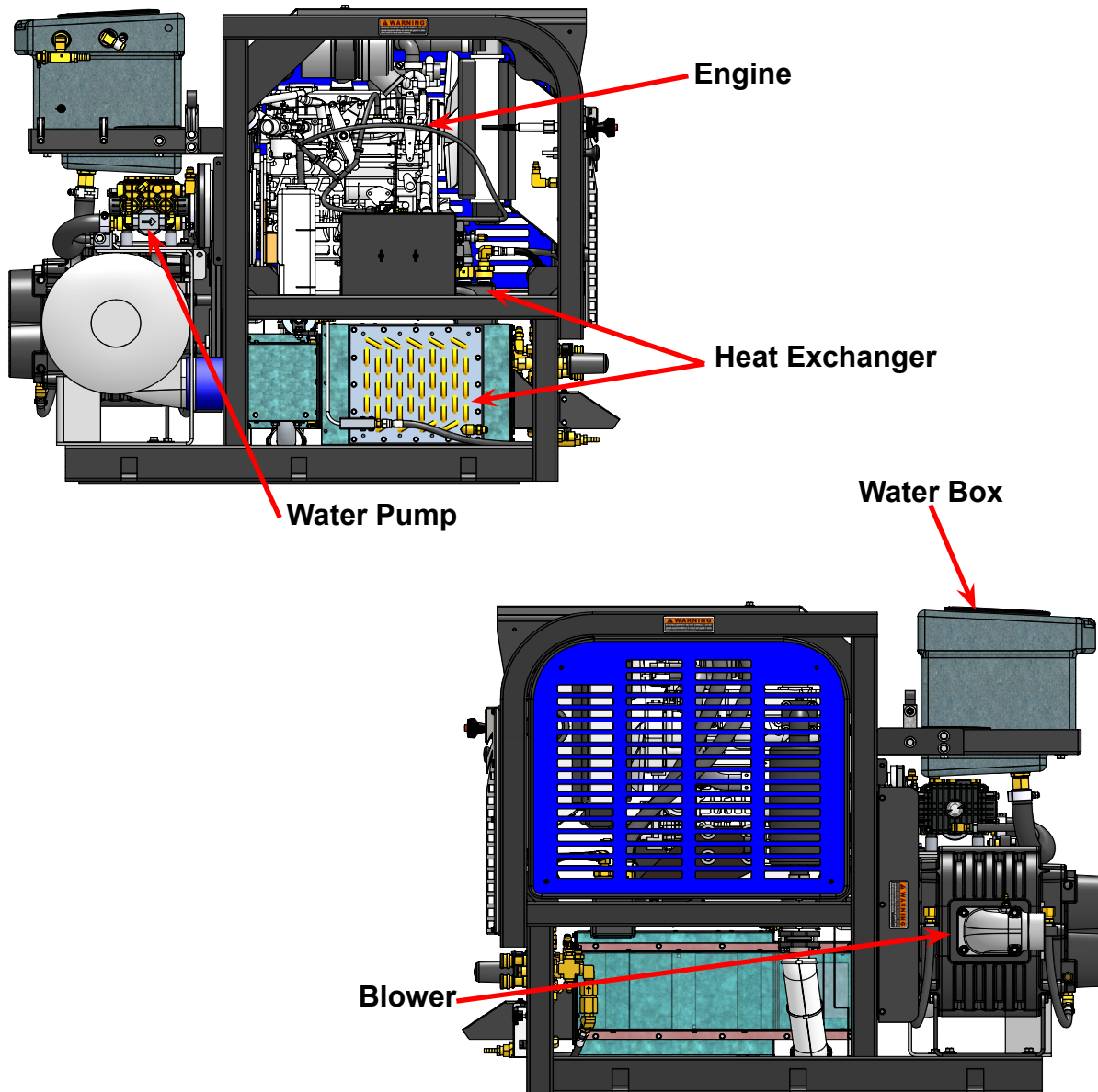

TITAN 575

CONTACT INFORMATION

If you have any questions regarding the operation, maintenance or repair of this machine, please contact your local distributor.

To find a local distributor, please visit our website at <https://hydramaster.com/dealer-locator/>

If your question cannot be resolved by your distributor or by the information within this manual, you may contact HydraMaster direct using the following phone numbers.

HOURS	TELEPHONE NUMBERS	E-MAIL ADDRESSES
Monday-Friday 7:00 a.m. to 5:00 p.m. Pacific Time	Technical Support (800) 426-1301 FAX : (800) 426-4225	Technical Support techsupport@hydramaster.com
	Customer Service/Parts (800) 426-1301 FAX : (800) 426-4225	Customer Service/Parts parts@hydramaster.com

When calling your distributor, be sure to reference the serial number and date of purchase.

FOR YOUR REFERENCE:

Serial No. _____

Date of Purchase: _____

Purchased From (Distributor): _____

TITAN 575

RESPONSIBILITIES

Purchaser's Responsibilities

- Prior to purchasing a van, ensure that the payload is suitable for all of the equipment that will be installed and transported. This includes and is not limited to: the truckmount, recovery tanks, fresh water tanks and any other on-board water, hose reels, hoses, cleaning tools, chemicals and drying equipment. Payload capacity information is available through the auto dealer, the manufacturer's web site, and is also located on the door pillar of the driver's side door.
- Purchase a heavy duty Group 24 (550 CCA or better) battery for this truckmount. This is normally available from the installation dealer.
- Prior to dropping your van off at the distributor for the truckmount to be installed, have a spray-on bed liner applied to the floor such as Rhino Lining® or Line-X®.

NOTICE

Plywood and carpet are not recommended.

- Prior to operating the truckmount, read this manual in its entirety and familiarize yourself with the information contained here. Special attention should be paid to all **Warnings and Cautions**.
- The distributor is responsible for the correct installation of the truckmount. The distributor is also responsible to train you in the correct and proper operation and maintenance of the truckmount.

NOTICE

Any modification of the truckmount may void the warranty.

TITAN 575

Distributor's Responsibility

Acceptance of Shipment

Before accepting the truckmount, check the following:

1. The truckmount should be free from any damage during shipping. Do not sign the delivery receipt until you have closely inspected the truckmount and noted any damage on the delivery receipt. Hidden damage may be present even if the box looks okay. It is recommended that the box be opened before you sign for the shipment.
2. Check the packing list and verify that all items are accounted for.

Installation Responsibilities

- Ensure proper payload capacity. It is the distributor's responsibility to verify that the equipment package does not exceed the vehicle capacity.
- Ensure installation of a safe fuel tap system and through-floor fittings as provided by HydraMaster.
- Ensure proper placement of the truckmount, recovery tank, fresh water tank, and accessories in the vehicle, and check that they are secured with bolts and back up plates. The distributor should verify that the owner is in agreement with the layout.
- Ensure proper connection of the fuel lines.
- Ensure proper connection and installation of the battery. Verify that the battery is in accordance with HydraMaster's recommendation.
- Check the pump, vacuum blower and engine oil levels prior to starting the truckmount.
- Start and run the truckmount and check that all systems function properly.
- Test all hoses, wands and other accessories for correct operation.
- Ensure timely return of the document package.

TITAN 575

Training

The distributor should provide a thorough review of the operation manual with the purchaser along with instruction and familiarization in:

1. How all the truckmount's systems function.
2. All safety precautions and their importance.
3. How to correctly start and shut down the truckmount.
4. How to correctly clean with the truckmount.
5. Where and how often to check and change component oil levels.
6. Freezing damage and how to avoid it. This includes explaining proper freeze guarding procedures.
7. How to do basic troubleshooting of the truckmount.
8. Hard water damage and how to avoid it. This includes how to determine if hard water exists in your area and the installation and use of water softening systems.
9. The truckmount's warranty and warranty procedures.

TITAN 575

MACHINE SPECIFICATIONS

Frame Dimensions	26.0" W x 45" D x 39" H	
Weight	900 lbs	
Engine - WG 972 Kubota	Oil Type	5W-30 Synthetic
	Capacity	3.2 quarts when changing oil and filter
	Engine rpm	High - 3,000 rpm
		Idle - 1,500 rpm
	Fuel Consumption	1.6 gph
Ignition	Keyless	
Vacuum Blower - Tuthill 4007 Competitor (Dual Splash Lubrication)	Max. Vac.	12" Hg
	Oil Type	PneuLube or other ISO 100 rating
	Gear End Capacity	Approx. 5.8 oz.
	Drive End Capacity	Approx. 4.7 oz.
	Blower rpm	3,000 rpm
Water Pump- General Pump	Oil Type	15W-40
	Capacity	14 oz.
	Pump Rate	4.0 gpm
	Pump rpm	1,700 rpm
Operating Pressure	0 - 1,200 psi (heated)	0 - 2,000 (no heat) *
Chemical System	Last Step Chemical Injection	

* Pressure washing option

TITAN 575

Heating System	Cross Flow Heat Exchanger	Coolant Heat Exchanger
Standard Equipment	High Pressure Solution Hose	1/4" High Temperature Lined/Vinyl Cover - 100 ft.
	Vacuum Hose	2" Vacuum Hose - 100 ft.
		1-1/2" Wand Whip Line - 10 ft.
	Recovery Hose	10 ft
	Water Box	Rotomolded 7 gallon capacity
Available Equipment	Recovery Tank	70 gallon Universal Tank
	Cleaning Wand/Tool	Evolution Wand
	Garden Hose	
	Chemical Jug	5 gallon
	Battery Box	
	Van Decal	
	Van Installation Kit	
	Owner's Manual (on USB) Owner's Guide (printed)	

NOTICE

The Titan 575 comes standard with an exhaust deflector to which a hose cannot connect. HydraMaster strongly recommends you purchase the Exhaust Thru Floor Kit which directs the hot air outside of the van, away from the machine. This kit is highly recommended for vans with barn doors.

TITAN 575

SPARE PARTS

The following table is a list of available Titan 575 spares that distributors may purchase to have on hand for repairs and maintenance.

Part No	Description	Qty
000-010-128	Belt, 9330HD Pump Drive	1
000-010-131	Belt, 3vx450 Eng. Drive	3
000-025-003	Cable, Choke, With Detent	1
000-025-033	Cable, Throttle	1
000-049-023	Filter, Garden Hose Screen	1
000-049-063	Filter, Air	1
000-049-152	Filter, Recovery Tank Basket	1
000-049-153	Filter, Flat URT	1
000-049-256	Filter, Oil - Kubota	1
000-049-257	Filter, Fuel	1
000-052-051	Quick Connect, 440 Female	2
000-052-052	Quick Connect, 660 Male	1
000-056-011	Fuse, 30 Amp Circuit	2
000-074-007	Gauge, Pressure	1
000-074-125	Controller, Temperature	1
000-078-521	Kit, Valve, 4.0 gpm General	1
000-078-522	Kit, Seal, 4.0 gpm General	1
000-087-006	HydraMaster-recommended Lubricant Blower Spray - part number is for 1 can	1 ea
000-149-039	Sender, Temperature	1
000-149-566	Sensor, RTD 6" 90 Degree	1
000-157-022	Switch, Relay	2
000-157-040	Switch, 12V DC, On/Off	2
000-157-152	Switch, Ignition, 3-Way	1
000-169-0171	Valve, 3-Way (Chemical)	1
000-169-022	Valve, 1 1/2" Full Port	1
000-169-160	Valve, 2-Way (Chemical)	1
000-169-213	Valve, 1/4" NPT 3-Way (Heat Selector)	1
000-169-224	Valve, Mechanical 145 Degrees F	1

TITAN 575

HIGH ALTITUDE OPERATION

Elevation plays a key role in how the truckmount will operate. Operation at high altitude above 5,000 ft may require a high-altitude carburetor jet. Use of this jet at high altitude will improve power, reduce fuel consumption and help reduce excessive carbon build-up in the exhaust and heat exchanger systems.

Contact the local Kubota dealer or HydraMaster to obtain the proper jet size. Find your local Kubota dealer at <http://www.kubotaengine.com/us-engine>

LOCAL WATER PRECAUTIONS

The quality of water varies greatly. Many areas have an excess of minerals in the water which results in what is commonly called “hard water.” These minerals tend to adhere to the insides of heater coils and other parts of the machines causing damage and a loss of cleaning effectiveness. This influences the reliability and efficiency of equipment in direct proportion to the level of hardness.

Hard Water Advisory

HydraMaster recognizes that any hard water deposits which might occur within the water system of our truckmounts is a serious problem. The precision technology of truckmount heat exchanger systems is intolerant of any foreign material. Hard water deposits will ultimately decrease the performance of the system and are expected to seriously lower the reliability of the machine.

To validate a machine’s warranty, HydraMaster requires that all machines operating in designated “Hard Water Areas” (3.0 grains or more per gallon) be fitted with a water softening system, or a properly installed magnetic-type descaler must be used and maintained. Periodic descaling or acid-rinsing alone is not adequate in these areas. HydraMaster does not recommend any particular type or brand; however, the relative effectiveness of some types of magnetic descalers or softeners may require additional periodic use of descaling agents.

HydraMaster also recommends, in the strongest possible terms, that machines in all areas be fitted with a water softening system for improved operation and reliability.

CAUTION

Failure to take appropriate measures to prevent scale build up can result in system failure and loss of warranty on affected parts.

TITAN 575

Hard Water Area Map

The hard water map, shown in Figure 1-1, defines hard water areas in the continental United States which compromise fluid related components such as hoses, fittings, heaters, pumps, valves and water-cooled engines. For other countries, hard water area maps can be obtained from geological societies.

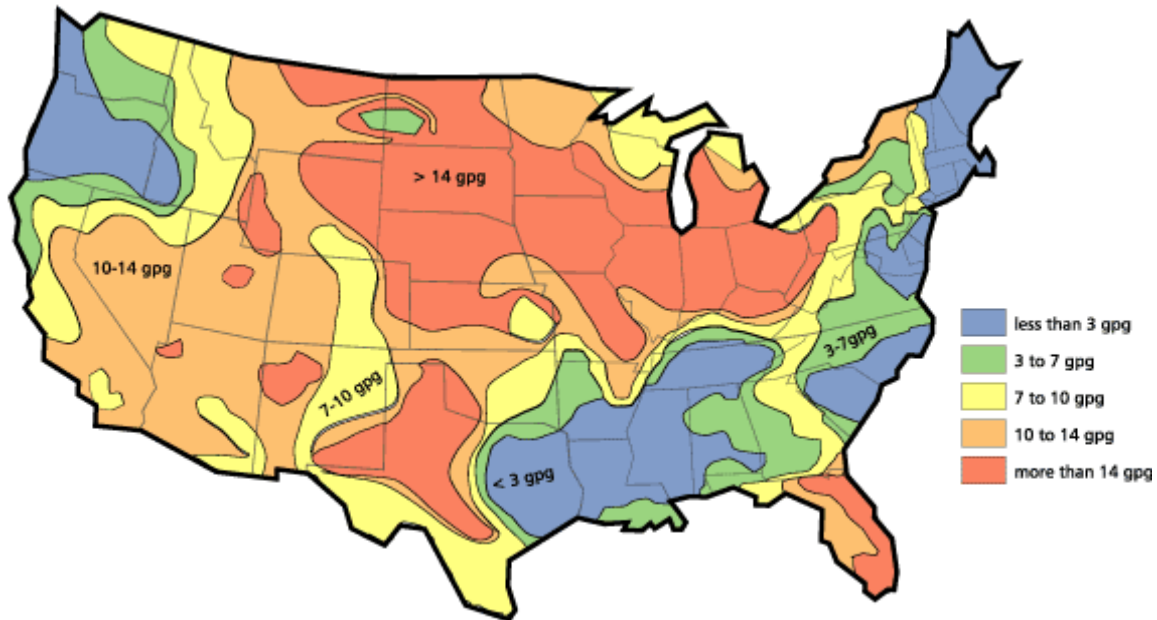

Figure 1-1. Hard Water Map of Mainland United States

NOTICE

The map shown in Figure 1-1 is provided for general reference only. Water hardness in your geographical location should be confirmed by testing.

Water Softener

Cleaning efficiency and equipment life is increased, chemical use decreased, and the appearance of cleaned carpets enhanced when water softeners are incorporated in hard water areas. HydraMaster strongly urges the use of water softener units with the Titan 575 in areas exceeding 3.0 grains per gallon.

Failure to use a water softener in these areas will invalidate the machine's warranty. Referring to the hard water area map shown Figure 1-1, determine the quality of water in your area and take immediate action if the water hardness exceeds 3.0 grains per gallon.

The relatively low cost of a water softener service is more than made up for by an increased life of machine parts, reduced chemical costs and continued cleaning efficiency. The water softener will also increase the effectiveness of the cleaning chemicals, therefore less chemical will be needed.

TITAN 575

Contact a water softener distributor in your area for information on the rental of a simple water treatment unit to carry in your truck. Be sure to charge the water softener in accordance with the capability of the softener.

For example: If the softener will treat 900 gallons of water and the machine uses an average of 30 gallons/hour, for an average of 5 hours a day, this equals 150 gallons per day. In 6 days the machine would use 900 gallons of water. Therefore, the softener would need to be charged every 6 working days for maximum softening.

Waste Water Disposal Advisory

There are laws in most communities prohibiting the dumping of recovered “gray” water from carpet cleaning in any place but a sanitary treatment system.

The cleaning rinse water, recovered into your unit’s vacuum tank, contains materials such as detergents, and must be safely processed before entering streams, rivers and reservoirs.

In most cases, an acceptable method of waste water disposal is to discharge into a municipal sewage treatment system after first filtering out solid material such as carpet fiber. Access to the sanitary system can be obtained through a toilet, laundry drain, RV dump, etc. Permission should first be obtained from any concerned party or agency.

One disposal method which usually complies with the law is to accumulate the waste water and haul it to an appropriate dump site. Another solution to the disposal problem is to equip your Titan 575 with an Automatic Wastewater Disposal System (AWDS). These systems are designed to remove waste water from the extractor’s recovery system and actively pump the water through hoses to a suitable disposal drain.

HydraMaster makes an AWDS System which can be ordered with new equipment or installed later.

When properly configured, the systems will continuously monitor the level of waste water and pump it out simultaneously with the cleaning operation. The hidden benefit of this process is that the technician does not have to stop his/her cleaning to empty the recovery tank.

NOTICE

IN ACCORDANCE WITH EPA, STATE AND LOCAL LAWS, DO NOT DISPOSE OF WASTE WATER INTO GUTTERS, STORM DRAINS, STREAMS, RESERVOIRS, ETC.

The penalties for non-compliance can be serious. Always check local laws and regulations to be sure you are in compliance.

TITAN 575

2 - Installation Information

Although there are many different heavy duty vehicles used for carpet cleaning equipment, the preferable vehicle for a Titan 575 installation is a cargo van with a heavy-duty suspension package and a 3/4 HD ton capacity. If a fresh water tank is added, a one ton or larger capacity van is required.

Prior to installation of the Titan 575, HydraMaster recommends installing a spray-on bed liner in the vehicle. This provides 'metal to cushion' mounting rather than 'metal to metal' and makes for an attractive van interior.

HydraMaster also recommends installing roof vents in vehicles operated in hot weather locations. Roof vent positions are shown in Figure 2-1. Consult your local RV distributor about selection and/or installation of powered roof vents.

For best results, the fan should draw air into the vehicle which will supply cooler air to the air cleaner intake.

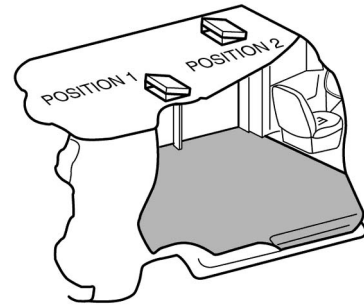

Figure 2-1. Location of Roof Vents in Vehicle

CAUTION

HydraMaster requires a powered roof vent above the air cleaner intake. Failure to install a powered roof vent in such a manner may result in serious component or engine damage.

TITAN 575

OPERATING THE TITAN 575 IN HOT WEATHER

HydraMaster recommends the following steps when operating the Titan 575 during periods of hot weather (95° F or higher). This will help ensure that your Titan 575 continues to run at 100% capacity during even the hottest days.

1. A minimum of 9” of clearance is required on both sides of the Titan 575, when installed. Ensure that additional equipment or other materials are not stored at the sides or on top of the Titan. Unobstructed airflow around the unit is critical for cooling the engine and other components.
2. For side-door vans with “barn doors”, open the doors as wide as their construction will allow. Be sure to open the doors beyond their standard “straight-out” position, if possible, by releasing the stops and putting the doors in their fully extended position.
3. Provide cross-ventilation. When possible, keeping the rear doors open while the Titan is running will substantially reduce the temperature inside the van and will provide a path for cooling air flow. For rear-mount installations, open up the other doors in the van.
4. Consider adding powered roof vents to the vehicle (if not already installed). These vents can significantly reduce interior temperatures and will result in much cooler operation. A powered roof vent is required when the Titan 575 is mounted on the optional 85 Gallon Fresh Water Tank.
5. Run the Titan 575 in HOT mode when outdoor temperatures are high. Running the Titan in WARM mode is not “easier” on the machine. In fact, it cuts the coolant heat exchanger out of the cleaning solution loop, in effect reducing the engine-cooling capacity. The Titan was designed to deliver solution at the optimum temperature to clean carpets when in the HOT mode. The WARM mode is intended for delicate materials like upholstery.

TITAN 575

CAUTION

Use caution when drilling any holes through the van floor. Many vans have critical components mounted directly below the vehicle floor that could be damaged by a misplaced drill bit.

LOCATING THE TITAN 575 IN VEHICLE

There are two recommended entry points on the vehicle for the Titan 575 installation: the side door or the rear doors.

Most installations are through the side door. This provides rear access for accessories and hoses as well as unobstructed access to the component/working side of the machine, thus making it a bit easier to perform maintenance and/or repair without removing the unit from the truck.

Rear mounting requires the unit to be slid to the right side as far as possible. Although installing the Titan 575 through the rear door partly limits working access, it does direct the noise away from the cleaning site.

In addition, rear mounting not only provides adequate working space on the component side of the unit but also improves weight distribution inside the van (engine and component weight line up over drive shaft). Some cleaners in colder geographical areas prefer this placement for better traction in ice and snow. Also, it is physically easier to load the unit into the rear door due to the height of the vehicle bed.

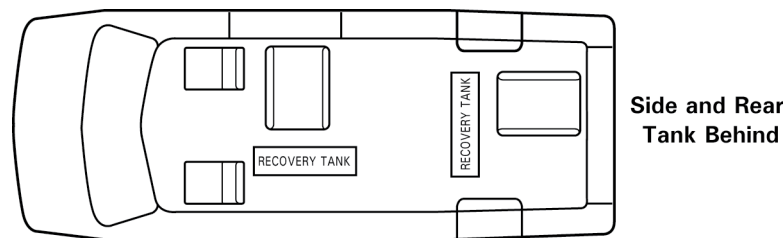

Figure 2-2. Recommended Location of Titan 575 in Van

Secure Installation

No matter how the unit is installed, check to see if the Titan 575 is properly secured to the floor of the van with the hardware provided. This safety measure will ensure that the machine will not slide inside the van. See Figure 2-2 for the correct installation.

To install the 85 gallon fresh water tank, follow the procedure outlined in the kit instructions for P/N 000-079-125.

TITAN 575

⚠ WARNING

A sudden or crash stop will cause the machine to rocket forward if not properly secured. To prevent serious personal injury, ensure that the Titan 575 is well secured to the floor of the vehicle with the hardware supplied. Protect yourself and the machine.

⚠ WARNING

HydraMaster strongly recommends that the exhaust from the front of the machine be vented down under the truck to prevent carbon monoxide from entering the job site. **Always park the truck so the exhaust is blowing away from the job site.**

⚠ WARNING

Never operate this machine with a portable gas can inside the truck. Doing so increases the risk of a fire or explosion.

⚠ WARNING

Mount a fire extinguisher just inside the rear or side door for emergencies.

⚠ WARNING

Do not use a portable propane tank inside of the truck or van. It is dangerous and illegal in most states.

⚠ WARNING

Transporting any vented fuel container that presently holds or has ever held a flammable liquid in a vehicle containing the Titan 575 is strictly forbidden by HydraMaster Corporation and by federal and state regulation.

⚠ WARNING

The engine exhaust from this product contains chemicals known to the State of California to cause cancer, birth defects or other reproductive harm.

TITAN 575

SETTING UP THE TITAN 575

Prior to operating the Titan 575, follow these steps:

1. Adjust the vacuum relief located on the recovery tank by capping all the vacuum inlets. The machine should be set to 12" Hg maximum.

CAUTION

Setting the vacuum level higher than the recommended value can result in an increased risk of serious component damage.

The Titan 575 is shipped from the factory with antifreeze added to the solution system. Recover this antifreeze and dispose of the recovered antifreeze as stated in the local laws and regulations.

⚠ WARNING

KEEP ANTIFREEZE OUT OF REACH OF CHILDREN AND ANIMALS. Drinking antifreeze can cause death.

If required, dispose of antifreeze at facilities licensed to accept household hazardous waste. If permitted, dispose of antifreeze in sanitary sewer systems. Do not pour antifreeze into storm sewers, septic systems, or onto the ground. Doing so causes health and environmental dangers.

CAUTION

Ensure the antifreeze is completely drained from the solution system. If any antifreeze remains in the system, it could damage machine components and damage fabric.

3 - Cleaning Information

The Titan 575 has been engineered using the latest and most sophisticated technology available to produce the finest carpet cleaning results possible. Despite this, it remains only a tool of the carpet cleaning trade and can produce only as good a job as the person operating it.

HydraMaster strongly recommends attending the Institute of Inspection, Cleaning and Restoration Certification (IICRC) as soon as possible and to always follow the IICRC guidelines when cleaning carpets or hard surfaces.

This section describes the carpet cleaning procedure in the following areas:

- Precautions
- Preparing the Carpet for Extraction
- Rinse and Recover
- Overwetting
- Streaking
- Cleaning Tool Tips
- Severe Cleaning Situations

PRECAUTIONS

The use of some chemicals (such as concentrated acids and/or solvents) in your truckmount can seriously damage the internal plumbing and high pressure pump.

CAUTION

If concentrated acids or solvents are used to pre-treat surfaces before power washing, do not recover them through the vacuum system.

HydraMaster strongly recommends purchasing a water softener system to prevent the buildup of scale and hard water deposits in your truckmount.

HydraMaster recommends only the use of chemicals containing rust and corrosion inhibitors and water softening agents to prevent chemical buildup which may lead to component failure and warranty invalidation.

Increased demand for a neutralizing rinse results in the need for special care when using these acid based chemicals in your truckmount. The negative side of these products is the corrosive effects the acid can have on metals, including fittings, pumps, heat exchangers, etc.

HydraMaster's **ClearWater Rinse™** has been formulated to protect vital components. HydraMaster will not warranty parts that have been damaged from using acid products that have obviously caused failures.

TITAN 575

PREPARING THE CARPET FOR EXTRACTION

Pre-vacuum the carpet

Whether you instruct the customer to pre-vacuum or you offer it as part of your service, proper vacuuming will make your job easier with superior end results. The more time spent removing loose particulate soil, the easier it will be to remove the oily soil stuck to the fibers.

Pre-treat the carpet

This process of applying traffic lane type chemicals to the carpet (whether by sprayer or rotary scrubber) is essential prior to extraction with your truckmount.

By applying cleaning agents to the carpet and letting them dwell 10-20 minutes prior to rinsing, you allow the product to dissolve and emulsify the oily, sticky binders holding the soil to the fiber. This will allow more soil to be removed in one or two cleaning passes and help prevent over-wetting.

Remember the solution coming out of your cleaning tool is only in contact with the carpet fiber for a few seconds. Relying on the rinse detergent to do the majority of the cleaning will result in overly long dry times and excess detergent residue left in the carpet.

HydraMaster recommends the use of our pre-sprays: **Fastbreak™** for residential carpet and **Blitz™** for commercial carpet needs.

RINSE AND RECOVER

Whether you are using a wand or an RX20®, you should clean an area approximately 3 ft. x 3 ft. with the solution valve open then immediately go over that area with vacuum only to remove any excess moisture.

Olefin fiber is becoming more popular, particularly in commercial installations. The process mentioned above can leave excessive residual moisture because olefin fibers will not absorb any of the cleaning solution. You must only apply solution during the backward stroke of the wand so it can be immediately captured by the vacuum head. RX-20™ users should follow each pass with a dry pass. Failure to follow this procedure will cause solution to flow to the back of the carpet along with some of the soil. This, along with any soil imbedded in the backing, will be wicked to the surface of the fibers as the carpet dries.

HydraMaster recommends the following rinse aids: Alkaline - **Hydra-Dri Powder™** or **Hydra-Clean™**. Acid - **ClearWater Rinse™**.

TITAN™ 575

OVERWETTING

Overwetting is an annoyance to all concerned. Extended drying times will leave the customer with a negative impression of both the cleaning company and the process used.

Several factors that will cause over-wetting include:

1. Too few vacuum strokes.
2. Clogged vacuum blower filter or vacuum tank lid not sealing properly.
3. Vacuum tank drain valve left partially open.
4. Obstructed, cut or kinked vacuum hoses.
5. Obstructed vacuum hoses while cleaning a heavily foam-saturated carpet (it is recommended to use a crystal type de-foamer distributed evenly over the carpet).

STREAKING

Streaks in the carpet can appear in both clean or dirty areas and normally appear in heavily soiled, light colored carpets.

Possible reasons of streaking may include:

1. Clogged or improperly angled spray nozzles.
2. Spray nozzles that overlap, concentrating the solution.
3. A partially clogged vacuum head.
4. Inconsistent solution temperature.

TITAN 575

CLEANING TOOL TIPS

Wands

With a wand, keep cleaning strokes short, front to back, and run a “dry pass”.

After pulling the wand for a strip of 3 or 4 ft long with the solution trigger activated, go back up to the top of the stroke, and make a “dry “ pass [i.e. no solution flowing]. This gives the wand a second chance to pick up the solution on the carpet.

If you do not run a dry pass, the carpet can take longer to dry, and, possibly, the pad under the carpet can become saturated.

Be aware of the carpet seams; try to use strokes that are parallel with the seam. Avoid pulling the wand across the seam. Every stroke can peel the seam connection and pull the carpet off the floor.

Also, tilt the wand handle down [head up] to move the tool forward, and away from you, on the carpet. This means less pull on the carpet and less work for you.

4 - Operating Instructions

This section describes how to operate the Titan 575, starting with a description of the dash assembly (see Figure 4-1).

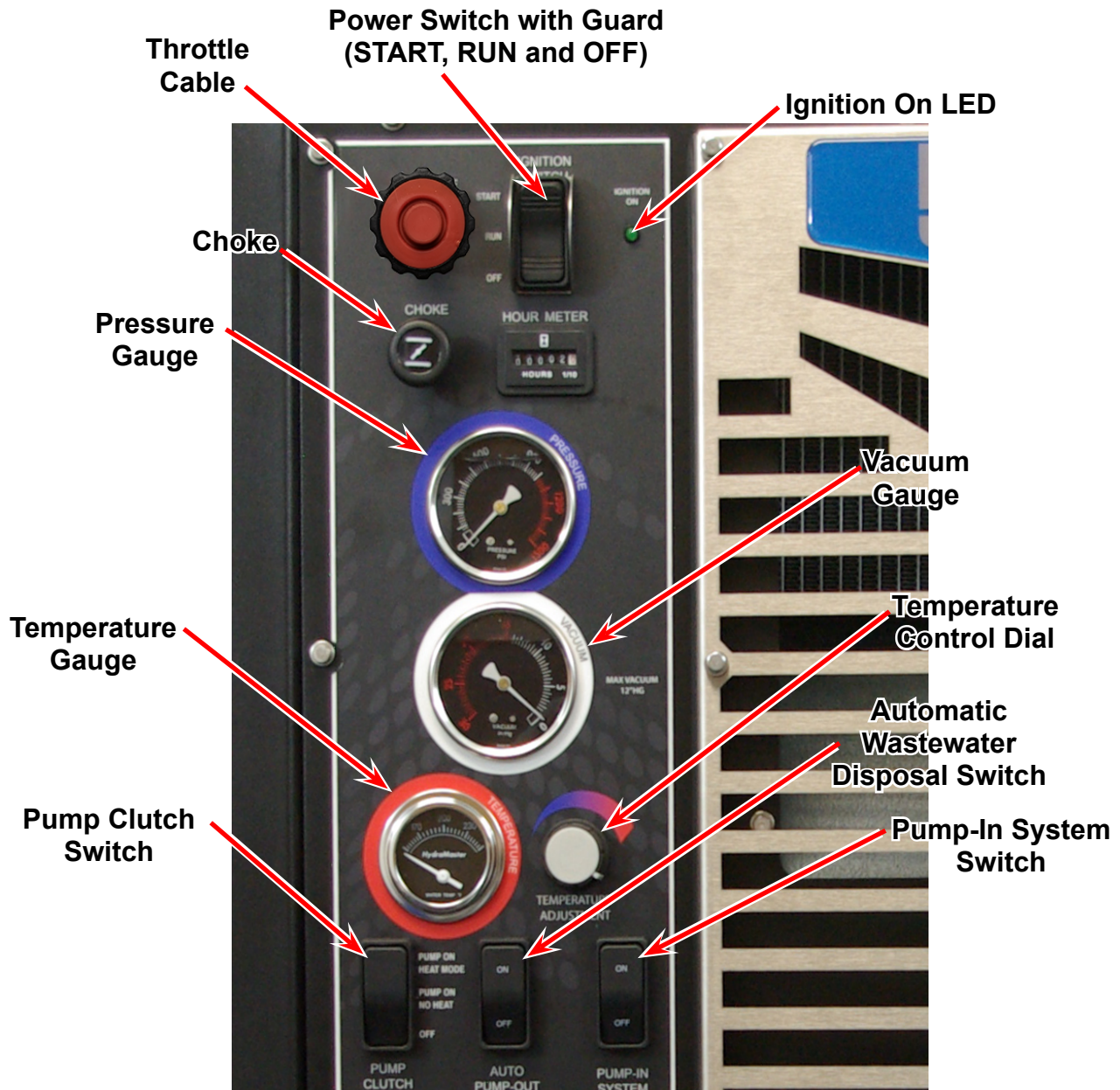

Figure 4-1. Titan 575 Upper Dash Assembly

TITAN 575™

The front dash assembly controls the:

- System's power on/off and engine speed
- Pump clutch
- Automatic Wastewater Disposal System (AWDS) if included in the configuration
- Pump-In system if included in the configuration

The front dash assembly also includes the solution temperature control dial; the temperature, vacuum and pressure gauges; the hour meter; and an ignition ON LED indicator. A switch guard surrounding the power switch helps prevent unintended power starts and stops.

The lower dash assembly controls the:

- Water pressure
- Chemical metering
- Water box drain
- Heat selection for carpet cleaning (HOT) or upholstery cleaning (WARM) - see Figure 4-2

Heat Selector Valve (WARM and HOT)

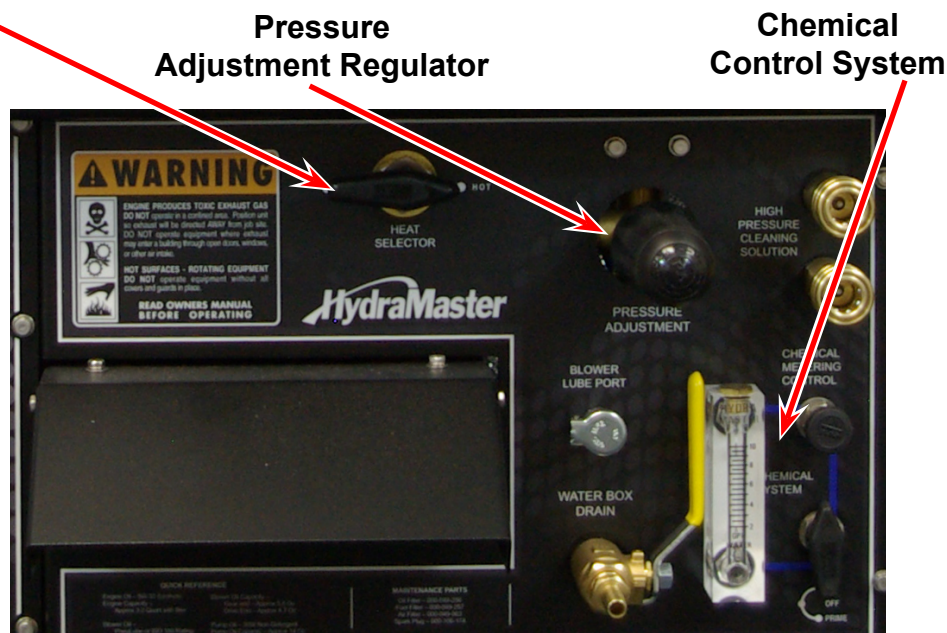

Figure 4-2. Titan 575 Lower Dash Assembly

The lower dash assembly also houses the blower lube port and the two high pressure cleaning solution port where the wand/tools connect to the Titan 575.

TITAN 575

CAUTION

To ensure proper operation of the exhaust diverter system, the Titan 575 must have a minimum of 5" Hg vacuum. If the vacuum level is lower than 5" Hg, the exhaust diverter will remain in "Divert" mode.

NOTICE

Photographs and illustrations included in this document can represent optional equipment as well as standard equipment.

SETTING THE TEMPERATURE

Depending upon the type of cleaning jobs you need to do, there will be times where you will not need the maximum heat and vacuum available. There are a few different ways you can optimize the Titan 575 to the size of the job.

The different scenarios can be defined as follows:

1. Maximum – Dual wands or rotary machine usage. This means that all available power is required.
 - a. Set the Heat Selector valve to "HOT" - see Figure 4-2.
 - b. Rotate the temperature control dial to "HOT" - see Figure 4-3.
2. Reduced Heat – Single wand with short hose runs to the job site.
 - a. Set the Heat Selector valve to "WARM".
 - b. Rotate the temperature control dial to "WARM".

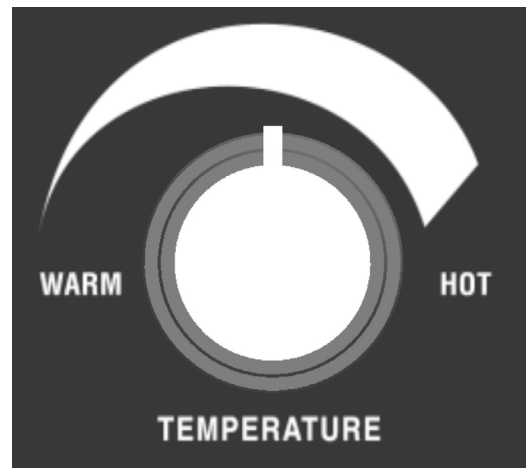

Figure 4-3. Temperature Control Dial

CAUTION

Never perform cleaning operations when the truckmount engine is running at the IDLE throttle position. To do so will increase the risk of serious component or engine damage.

TITAN 575

START-UP PROCEDURE

1. Perform all daily periodic maintenance as specified in this Owner's Manual.
2. Connect a garden hose to supply water to the truckmount. If the pump-in feature is used on your system, push the "PUMP-IN" switch to the "ON" position.
3. Connect the cleaning wand or tool to the length of hose required to perform the cleaning job.
4. Start the truckmount with:
 - a. The throttle cable in the "IDLE" position.
 - b. Pull the choke cable out if the engine is cold.
 - c. The "PUMP CLUTCH" switch in the "OFF" position.
5. After the engine starts, allow the truckmount to run in "IDLE" for 2 - 3 minutes to warm up. Gradually push on the choke as the engine warms up.

CAUTION

Never clean when the Titan 575 is in the "IDLE" mode. Failure to follow this caution may result in serious component or engine damage.

6. Turn the throttle cable all the way out.
7. Press the "PUMP CLUTCH" switch to the "PUMP ON HEAT MODE" position for carpet cleaning or upholstery cleaning; for high pressure washing, press "PUMP ON NO HEAT"
8. Set the "HEAT SELECTOR" valve to the desired position.
 - a. Set to the "WARM" position for upholstery cleaning.
 - b. Set to the "HOT" position for carpet cleaning.
9. If the Automatic Pump-Out is included in your system's configuration, press the "AUTO PUMP-OUT" switch to the "ON" position.

TITAN 575

SETTING THE PRESSURE (FOR OPTIONAL HIGH PRESSURE WASHING KIT)

CAUTION

Lower the pressure below 1,200 psi prior to moving the “WATER PRESSURE SELECTOR” valve to “CARPET CLEANING” mode. Failure to do so may result in serious component or engine damage.

Set the cleaning pressure to the desired level as follows.

1. Carpet Cleaning: 300 to 400 psi: Position the “WATER PRESSURE SELECTOR” valve to “CARPET CLEANING” mode (if equipped). The system is designed to shut off above 1,200 psi to protect the heat exchanger system.
2. Hard Surface Cleaning: 1,200 psi or as indicated on tool. Position the “WATER PRESSURE SELECTOR” to “CARPET CLEANING” mode (if equipped). The system is designed to shut off above 1,200 psi to protect the heat exchanger system.
3. Pressure Washer Cleaning (if equipped): 2,000 psi or as indicated on tool. Position the “WATER PRESSURE SELECTOR” to “PRESSURE WASHING” mode (if equipped).

CAUTION

Do NOT apply a vacuum load while using the Titan 575 in “PRESSURE WASHING” mode. Doing so may cause the machine to overheat.

4. Turn the “CHEMICAL SYSTEM” switch to the “PRIME” position to purge any air from the system (see Figure 4-4).
 - a. With the truckmount running at full throttle, block off the vacuum intake to the recovery tank. The vacuum gauge should read 12” Hg. This will assist in priming the chemical system.
 - b. Allow the chemical to flow through the chemical meter at full flow for 30 seconds.
 - c. Turn the “CHEMICAL SYSTEM” switch to “ON.” The restriction can now be removed from the vacuum inlet.
 - d. While spraying solution from the cleaning tool, adjust the chemical flow by turning the “CHEMICAL METERING CONTROL” knob.
5. Begin cleaning.

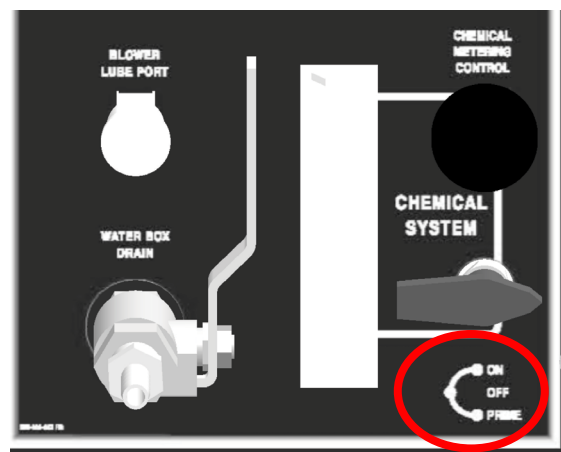

Figure 4-4. Location of Chemical System Switches

TITAN 575

SHUT-DOWN PROCEDURE

1. Flush clean water through the chemical system for 10 seconds. Turn the “CHEMICAL SELECTION VALVE” to “OFF.”
2. Cool the truckmount down by turning the “PUMP CLUTCH” switch to “PUMP ON - NO HEAT”. Spray the cleaning wand into the vacuum hose for 3-5 minutes. The chemical should now be flushed from the truckmount, hoses and cleaning tool.
3. Remove the vacuum hose.
4. Lubricate the blower to prevent it from rusting internally.
 - a. Allow the unit to run for a few minutes with the vacuum hose disconnected in order to remove moisture from the blower.
 - b. Cap off the inlet(s) to the vacuum tank.
 - c. Spray a HydraMaster-recommended spray lubricant into the “BLOWER LUBE PORT” for about 5 to 10 seconds while the unit is running (see Figure 4-5).

Blower Lube Port

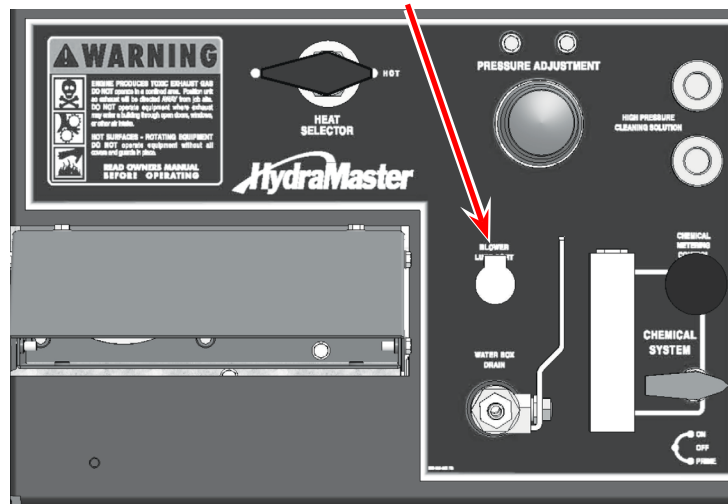

Figure 4-5. Location of Blower Lube Port

- d. Allow machine to run additional 2 to 5 minutes under load to flush off lubricant.
- e. Uncap the inlet(s) and run the unit for another minute to allow the blower to cool down.

TITAN 575

5. If freeze guarding is necessary, perform the procedure at this time. See the Freeze Guarding section of this Owner's Manual (see page 5-19).
6. Turn the throttle cable to the "IDLE" position.
7. Turn the ignition switch to "OFF."
8. Drain the water box using the valve.
9. Drain the vacuum tank in an appropriate location.

NOTICE

In accordance with EPA, state and local laws, do not dispose of water into gutters, storm drains, streams, or reservoirs.

10. Perform daily maintenance as specified in Section 5 of this Owner's Manual.

5 - Machine Maintenance

To avoid costly repairs and downtime, it is imperative to develop and practice good maintenance procedures. These procedures fall into daily, weekly, monthly and quarterly increments and are outlined below. All maintenance must be performed by qualified service personnel.

A maintenance log, provided in the Owner's Guide, must be correctly and completely filled out. HydraMaster may request to inspect the logs before a warranty claim is honored. It is recommended that the log be affixed to the vehicle door near the truckmount for convenience and to serve as a maintenance reminder.

This section describes how to properly maintain the truckmount in the following areas:

- Operational Maintenance
- Overall Machine Maintenance
- Engine Maintenance
- High Pressure Pump Maintenance
- Vacuum System Maintenance
- Descaling Procedure (Required)
- Freeze Guarding

TITAN 575

OPERATIONAL MAINTENANCE

Daily Maintenance

- Check the engine oil level. Add oil if needed.
- Check the high pressure pump oil. Add oil if needed.
- Check the oil level in the blower. Add oil if needed.
- Check coolant overflow bottle level. Add coolant if needed.
- Inspect and clean the recovery tank filters.
- Inspect and clean the garden hose screen.
- Inspect the truckmount for water and oil leaks, loose electrical connections, etc. and repair as needed.
- Lubricate the blower lube port with a HydraMaster-recommended lubricant.

Weekly Maintenance

- Inspect the recovery tank filters for tears, holes, etc. Repair or replace as needed.
- Inspect the sacrificial anode assembly in the tank and repair or replace as needed.
- Inspect the vacuum relief valve. Clean and lubricate as necessary.
- Clean the recovery tank thoroughly with pressure washer.
- Check the pump belt, blower belt drives, and fan belt for wear and proper tension. Adjust as needed.
- Check all the hoses and wiring for wear and chafing. Secure as needed.
- Flush the water and chemical systems with solution of equal parts white vinegar and water.
- Check all the nuts and bolts. Tighten as needed.
- One time change of the high pressure pump oil after 50 hours of operation. (Every 500 hours thereafter.)
- One time change of the engine oil and oil filter after 25 hours of operation.
- Change the engine oil every 100 hours. (Every 50 hours if operating in high ambient temperatures.) Change oil filter every oil change.

Monthly Maintenance

- Check the engine air filter. Clean or replace as necessary.
- Check the water level in battery. Fill as needed.
- Check engine fan belt.
- Clean the battery terminals as needed.
- Change the blower oil after first 100 hours of use.

TITAN™ 575

Quarterly Maintenance

- Check the fuel lines. Repair or replace as needed.
- Clean and gap the spark plugs to 0.028". Replace if excessive carbon buildup is visible.
- Change the high pressure pump oil.
- Check fuel filter. Replace as necessary.

500 Hours

- Change the blower oil.
- Change fuel filter.
- Change coolant.
- Replace blower drive belts.
- Replace the sacrificial anodes in the tank.

1,000 Hours

- Replace spark plugs.
- Change air filter.
- Check the engine valve clearance (intake and exhaust 0.006" to 0.0075").
- Check carburetor. Clean or replace as necessary.
- Replace engine fan belt.

NOTICE

Refer to the Interval in Hours Maintenance chart in the Owner's Guide for more information.

TITAN 575

OVERALL MACHINE MAINTENANCE

Maintenance, troubleshooting and repair are much easier tasks to accomplish on a clean truckmount. Regular cleaning of the truckmount offers the user an opportunity to visually inspect all facets of the truckmount and spot potential problems before they occur. In addition to the operational maintenance the following “housekeeping” duties should be performed.

After each job

- Check the recovery tank and the recovery tank filters. Empty and clean as necessary.

Daily

- Wipe the truckmount down thoroughly with a damp cloth.
- Wipe down the vacuum and high pressure hoses as needed.
- Inspect and clean the vacuum slot on the cleaning wand.
- Check the wand head for sharp edges that could tear carpet. File down as needed.
- Clean the wand to maintain original appearance.
- Visually inspect the hoses for abrasions, cuts, etc. Repair or replace as needed.

Weekly

- Empty the chemical container. Wash out thoroughly to remove any chemical buildup.
- Inspect the chemical feed line strainer and use solution of equal parts white vinegar and water to remove any chemical buildup.
- Thoroughly clean the wand and inspect for clogged jets, debris in vacuum slot and leaking fittings at valve.
- Thoroughly clean the vacuum and high pressure hoses including quick releases and cuffs.

TITAN 575

ENGINE MAINTENANCE

Engine Oil Level Check

The engine oil level should be checked daily. It is recommended that the oil be checked just before the engine is started for the first time for that day. The oil level should be between the 'Add' and the 'Full' marks on the dipstick.

CAUTION

Do not operate the engine with the oil level below the bottom of the 'Add' mark on the dipstick, or above the top of the 'Full' mark.

Adding Engine Oil

It is normal to add some oil in the period of time between oil changes. The amount will vary with the severity of operation. When adding or replacing engine oil, be sure the oil meets or exceeds the recommended specification.

Changing Engine Oil and Filter

The engine oil and filter must be changed every 100 hours or every 3 months whichever occurs first. The oil and filter should be changed more often if the engine is operating in dusty or extremely dirty areas, or during periods of high ambient temperature.

Engine Oil Quality

To achieve proper engine performance and durability, it is important that you use only engine lubricating oils of the correct quality in your engine. Proper quality oils also provide maximum efficiency for crankcase ventilation systems, which reduces pollution.

CAUTION

Use only engine oils displaying the American Petroleum Institute (API) "starburst" certification mark 'FOR GASOLINE ENGINES' on the container.

Engine Oil Recommendation

While multi-viscosity oils are generally recommended, SAE 5W-30 synthetic is specifically recommended year round for your Titan 575 engine.

TITAN 575

Oil Filter

Kubota engines use Kubota oil filters. An equivalent or better oil filter must be used when servicing the engine.

To replace the filter, use a proper filter wrench to remove the filter.

Clean the filter mounting base and lightly coat the gasket surface of the new filter with engine oil. Hand tighten the filter until the gasket contacts the base, then tighten another ½ turn. Fill the engine with the correct amount of oil, run the engine and check for oil leaks at the drain plug and oil filter gasket.

Spark Plugs

Always use the recommended spark plugs for your engine. Hotter or colder plugs, or similar plugs that are not exact equivalents to the recommended plugs, can cause permanent engine damage, reduce the engines useful life, and cause many other problems such as hard starting, spark knock and run-on. Installing new spark plugs regularly is one of the best ways to keep your engine at peak performance.

Cooling System

Coolant Level

Check the coolant level in the coolant overflow reservoir daily. Generally a good time to do this is just prior to starting the engine for the first time each day.

Maintain the coolant level in the radiator at ¾ " below the filler neck seat of the radiator when the coolant is cold. When the coolant level is checked, inspect the condition of the radiator caps rubber seal. Make sure it is clean and free of any dirt particles which would keep it from seating on the filler neck seat. Rinse off with clean water if necessary. Also make sure that the filler neck seat is free of any dirt particles.

▲ WARNING

Never remove the radiator cap under any condition while the engine is operating. Failure to follow these instructions could result in damage to the cooling system, engine, or cause personal injury. DO NOT add coolant to any engine that has overheated until the engine cools.

The engine manufacture requires the cooling system to be filled with a 50/50 mixture of glycol-based antifreeze. Distilled water is recommended in hard water areas.

CAUTION

Always maintain a 50% solution of phosphate-free/low-silicate antifreeze at all times for adequate heat dissipation, lubrication and protection from freezing. Major brands are typically low phosphate or phosphate free, and will be labeled accordingly on the container. It is recommended that you consult the technical data sheet for the brand of coolant you are using to determine if it meets the low phosphate requirement. Failure to use a 50% solution of phosphate-free/low-silicate antifreeze may result in corrosion of the cooling system.

Bleeding Air from Cooling System

It is necessary to remove all of the air from the engine to prevent overheating. If the coolant has been drained for any reason, it will be necessary to follow the bleed procedure.

When the engine is cold, remove the radiator cap. Fill the radiator until it is to the top of the filler neck. Start the engine and run in the low rpm position, pump clutch off, and no vacuum load. Allow the engine coolant to heat up and open the thermostat several times. As all the air is removed from the system, the level of the radiator should lower below the internal tubes. This process should take approximately 5 - 10 minutes. Top off the coolant and install the cap. In the event you experience a coolant shutdown due to overheat, allow the machine to cool down and repeat this procedure.

Radiator

Inspect the exterior of the radiator for obstructions. Remove all debris with a soft brush or cloth. Use care to avoid damaging the core fins.

Fuel Filter

The fuel filter is located between the fuel pump and the fuel tank underneath the vehicle.

TITAN 575

HIGH PRESSURE PUMP MAINTENANCE

Daily

Check the oil level and the condition of the oil. The oil level should be up to the center of the sight glass on the side or rear of the pump or between the “MIN” and “MAX” lines on the dipstick. The dipstick may be found by removing the oil cap.

Periodically

Change the oil after the initial 50 hours of operation and every 500 hours after that. It may be necessary to replace the pump seals and check valves at 500 hours if the truckmount has been running in high ambient temperatures.

Refer to the Pump Servicing Section in the following page for more information.

CAUTION

If the oil becomes discolored or contaminated one of the oil seals may be damaged. Do not operate the pump if the crankcase oil has become contaminated. Do not rotate the drive shaft without oil in the crankcase reservoir.

The pump should never be run dry. Running the pump dry will cause premature wear on the seals, packing and plungers. Running the pump dry for a prolonged period of time may cause damage that cannot be repaired and voids warranty.

Do not run the pump with frozen water in the manifold. If there is a risk of freezing, freeze guard the truckmount. See the Freeze Guarding section on page 5-19 of this manual.

TITAN™ 575

VACUUM SYSTEM MAINTENANCE

The vacuum pump in this machine is commonly referred to as a “rotary positive displacement blower” or “blower” for short. The performance and life of the truckmount is greatly dependent on the care and proper maintenance it receives. The manual for the blower has been included. Review the manual for a better understanding of this piece of machinery.

CAUTION

To protect the blower from overloading and damaging itself, there is a vacuum relief system installed on the vacuum tank. When the vacuum tank inlet is completely sealed off a maximum of 12” Hg will be attained.

CAUTION

Solid objects entering the blower will cause serious damage to the internal components of the blower. Extreme caution should be used when the truckmount is being run for test purposes with the inlet to the blower open to the atmosphere.

CAUTION

Foam passing through the blower can lead to serious problems with the truckmount. It is important to keep the vacuum tank free of foam. The tank is protected from overflowing by a float kill switch; however, this switch is not activated by foam.

Daily

At the end of each day the internal components of the blower need to be lubricated. This helps to prevent rust deposits and prolongs the life of the truckmount.

To lubricate the blower:

1. Allow the unit to run for a few minutes with the vacuum hose disconnected in order to remove moisture from the blower.
2. Cap off the inlet(s) to the vacuum tank.
3. Spray a HydraMaster-recommended spray lubricant into the “BLOWER LUBE PORT” for about 5 to 10 seconds while the unit is running.
4. Uncap the inlet(s) and run the unit for another minute to allow the blower to cool down.

Periodically

Change the oil in both ends of the blower after the initial 100 hours of use. The oil is to be changed each 500 hours of use thereafter.

TITAN 575

DESCALING PROCEDURE (REQUIRED)

Scale deposits on the interior of the heating system can cause a noticeable loss in heating performance. Deposits of this kind result from hard water. The frequency with which descaling procedures are required will vary. If the area has particularly hard water, you may have to descale often.

To descale the system, add an appropriate descaler chemical to the water box. Circulate it through the system. Let it stand. Flush and repeat as necessary. Clean all screens and strainers, and check them frequently following descaling.

NOTICE

If using TM DeScaler™ through the flow meter, make sure to run clean water through the flow meter after this procedure.

To descale using the recirculation kit (P/N 000-078-058), start with an empty water box. Fill a third of the water box with TM DeScaler™. Follow the recommendations on the TM DeScaler™ label for proportions. Verify that the float is not lying horizontal, but floats below.

Attach the recirculation fitting provided in the kit to the garden hose quick connect (see Figure 5-19) and this combination to the front of the truckmount.

Attach one section of the solution hose to the outgoing solution fitting on the front of the truckmount and the other end to the garden hose and recirculation fitting combination that is attached to the front of the truckmount. Additional hoses may be attached inline if descaling of hoses is needed.

Start the truckmount and allow it to run for 3 to 5 minutes. Do not leave the TM DeScaler™ solution in the system. Flush the system with clean water and turn the truckmount “OFF.”

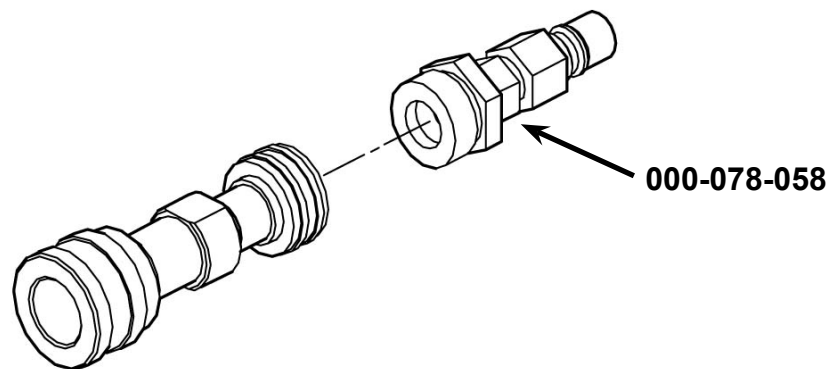

Figure 5-19. Recirculation Fitting

TITAN™ 575

FREEZE GUARDING

To avoid permanent damage to the truckmount, it is imperative to follow the Freeze Guard Procedure whenever the possibility of freezing temperatures exists.

CAUTION

When disposing of antifreeze, follow local laws and regulations. Do not discard into storm sewers, septic systems or onto the ground.

⚠ WARNING

Antifreeze is harmful or fatal if swallowed. Do not store in open or unlabeled containers. Keep out of reach of children and animals.

⚠ WARNING

When draining solution from the machine, wear protective eye wear and ensure the solution temperature is cold. Failure to follow this caution can result in personal injury.

TITAN 575

Freeze Guard Procedure

1. With the truckmount turned off and the incoming water line disconnected, open the water box drain valve on the front of the truckmount. Allow the system to fully drain. Close the water box drain valve.

NOTICE

In some extreme cold-temperature locations, you may find it necessary to disconnect the pressure gauge hose from the high pressure pump and drain the hose. Reconnect the hose to the pump before proceeding to step 2.

2. Add 2 gallons of 50/50 antifreeze and water mix to the water box.
3. Attach a recirculation fitting (see the previous page and Figure 5-19) to the incoming water quick connect on the front of the machine.
4. Attach a section of solution hose to the outgoing solution fitting on the front of the machine. Attach the opposite end to the recirculation fitting. (If more sections of hose are to be freeze guarded, attach those inline.)
5. Start the truckmount and allow it to run for 2 to 3 minutes. Turn the HEAT SELECTOR VALVE to "HOT" for 1 minute and then to "WARM" for 1 minute. This will distribute antifreeze solution throughout the truckmount.
6. Remove the chemical feed line from the chemical jug. Turn the SELECTOR VALVE to "PRIME." This will vacuum the chemical remaining in the lines to the recovery tank.
7. Remove the recirculation fitting from the truckmount.
8. Loosen the fitting at the back of the pressure gauge with a wrench after the antifreeze has been added to the machine to purge the coolant out of the fitting.
9. Re-tighten the fitting.
10. Spray the antifreeze and water mix out of the truckmount and into a container to reclaim the solution. Run the solution until it stops.
11. The truckmount is now freeze guarded. Remember to flush antifreeze from the system prior to carpet cleaning. See the following procedure.

NOTICE

The reclaimed antifreeze solution may be used three times before being discarded.

NOTICE

To freeze guard the hoses and wand, perform the preceding procedure with the items to be freeze guarded attached.

TITAN 575

CAUTION

Always check the freezing level of your reclaimed antifreeze with a glycol tester before reusing. Failure to do so may result in serious component damage.

Recovering Antifreeze for Re-Use

1. Attach all hoses and wands which have been freeze guarded to the truckmount.
2. Attach the incoming water source to the front of the truckmount.
3. Start the truckmount.
4. Spray the solution through the hoses and wands into a sealable container until all signs of antifreeze are gone.

Freeze Protection of the Pump-In System

1. Drain the fresh water tank.
2. Remove the garden hose adapter from the pump-in pump hose and position the hose so it is pointing outside the van.
3. Turn on the pump-in pump and run for 1 - 2 minutes until all the water is purged from the hose.

NOTICE

The next time the truckmount is used, it may take a few minutes before the water box begins to fill.

6 - Water and Chemical System

This section describes the Titan 575's water and chemical systems, and includes the exhaust subsystem.

Parts of the text are also included in the section's annotated illustrations which are referenced in the following paragraphs (see Figure 6-1 – Figure 6-6).

1. The process starts when fresh water is brought through the front of the truckmount into the water box, as indicated in Figure 6-1. The level of water in the box is maintained by the use of a float valve. The water is then gravity-fed to the pump where it is pressurized.
2. Next, the pressurized water enters the bypass valve. This valve allows manual adjustment of the pressure level. When the valve at the wand is closed, all the water in the system is recirculated to the water box. When solution is being used at the wand, the necessary amount of high pressure water passes through the bypass valve and to the heat exchanger (see Figure 6-1).
3. In the coolant heat exchanger, the temperature is raised. The heat necessary to do this is provided by the engine coolant. Heated water then travels to the blower heat exchanger. In this heat exchanger, the temperature of the water is raised once again. The heat necessary to do this is provided by both the engine and blower exhausts (see Figure 6-6). The heated water finally travels to the high pressure manifold (see Figure 6-6).

NOTICE

The high pressure manifold houses both the temperature sensor for the temperature gauge and the high temperature shutdown switch. This innovative, revolutionary system does not require a recirculation orifice or filter to maintain temperature within the heating system.

When water is not flowing through the cleaning tool, the water within the heat exchange system stops circulating completely.

TITAN 575

Water temperature is controlled via a temperature sensor inside the heat exchanger. When the system achieves the maximum operating temperature, the diverter valve will “divert” all heat away from the heat exchanger which allows the system to control its internal temperature without dumping water.

This saves valuable space in the recovery tank, which can be used instead for recovery of dirty water from the cleaning surface.

4. Water that is recirculated through the pressure regulator back to the water box travels past a thermostatic valve. This thermostatic valve monitors the water box temperature. When the controller senses the water in the water box has reached its set point, it opens the low pressure thermostatic valve on the side of the water box and closes once the temperature drops back below the set point (see Figure 6-2).
5. The water that is being called for by the wand then exits the manifold and passes through a check valve (see Figure 6-2).
6. Finally, the water joins the chemical where the solution is created (see Figure 6-2)
7. The chemical is pressurized by the HydraMaster diaphragm chemical pump attached to the head of the water pump. This pump pulls the chemical, or soap, jug through the chemical flow meter (see Figure 6-3).
8. After being pressurized, the chemical travels through the metering valve and is injected into the high pressure stream. This solution then exits the front of the truckmount and is delivered to the cleaning tool (see Figure 6-3).

Figure 6-1. Annotated Water, Chemical and Solution Flow Diagram - View 1 of 3
7459

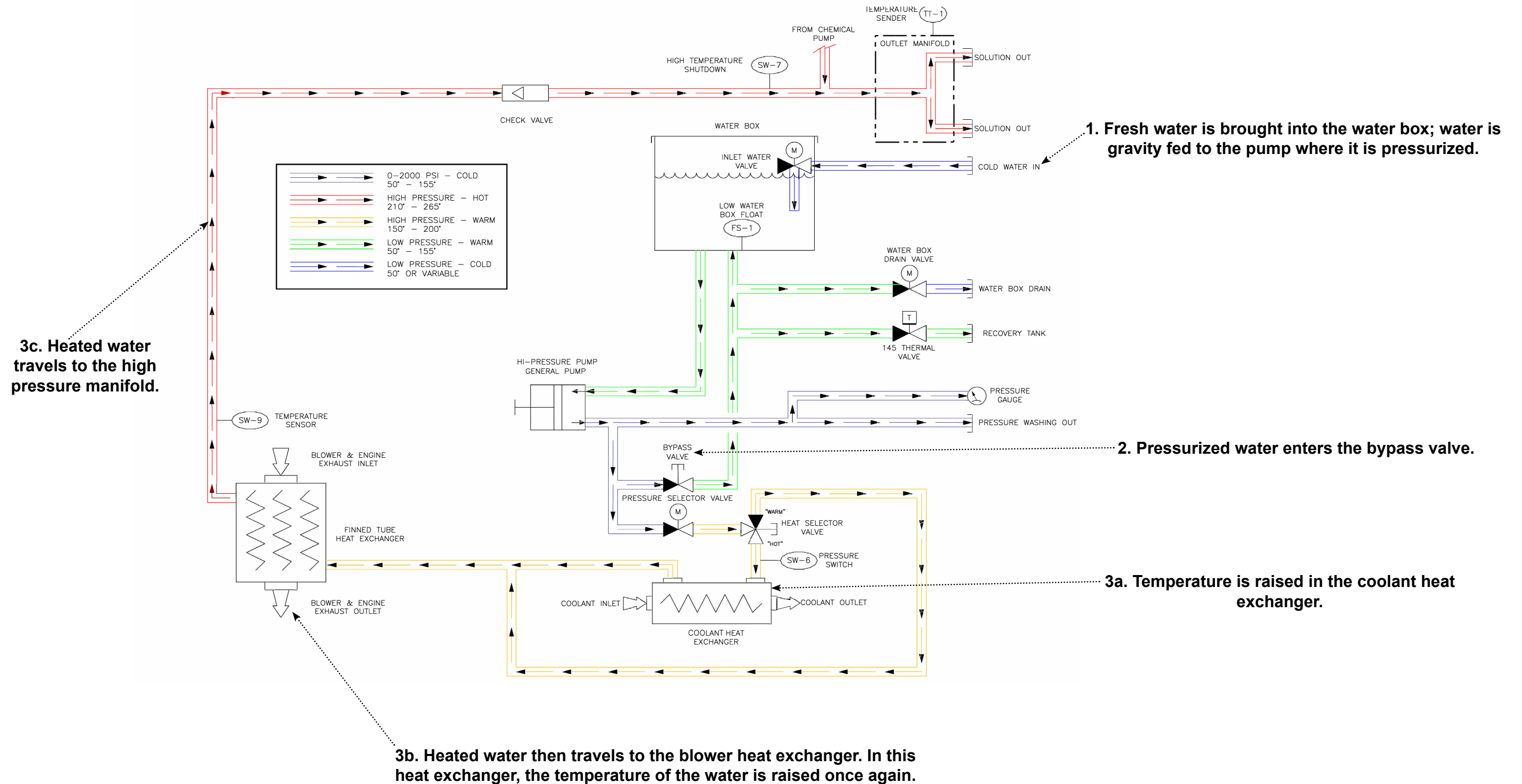

TITAN 575

Figure 6-2. Annotated Water, Chemical and Solution Flow Diagram - View 2 of 3
7459

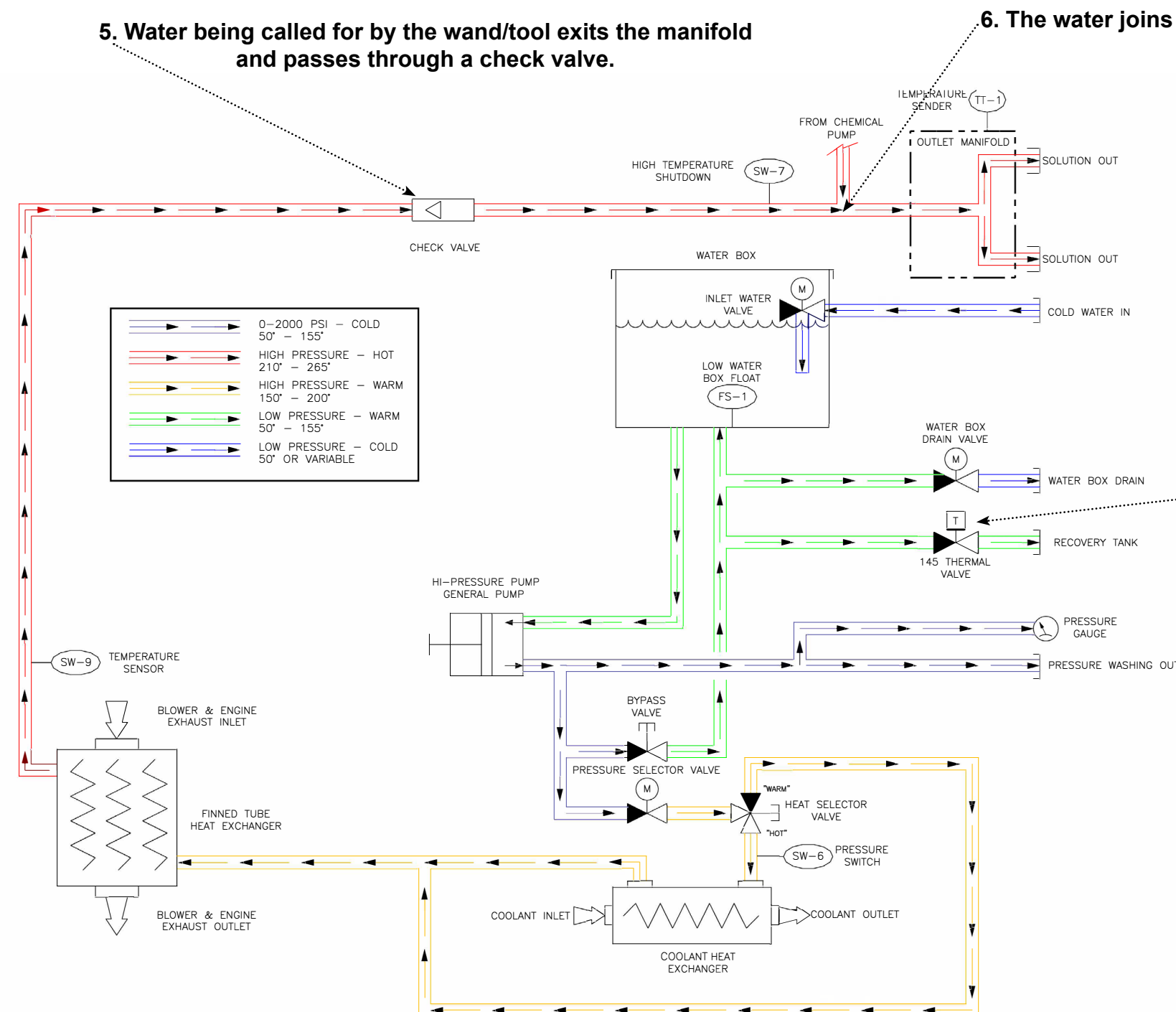

5. Water being called for by the wand/tool exits the manifold and passes through a check valve.

6. The water joins the chemical where the solution is created.

4. Water that is recirculated through the pressure regulator back to the water box travels past a thermovalve.

This thermovalve monitors the water box temperature.

When the controller senses the water in the water box has reached its set point, it opens the low pressure thermovalve on the side of the water box and closes once the temperature drops back below the set point.

Figure 6-3. Annotated Water, Chemical and Solution Flow Diagram - View 3 of 3
7459

8. After being pressurized, the chemical travels through the chemical flow valve and is injected into the high pressure stream. This solution then exits the front of the truckmount and is delivered to the cleaning tool.

7. Chemical is pressurized by the diaphragm chemical pump attached to the head of the water pump. This pump pulls the chemical from the chemical jug, or soap jug, through the chemical flow meter.

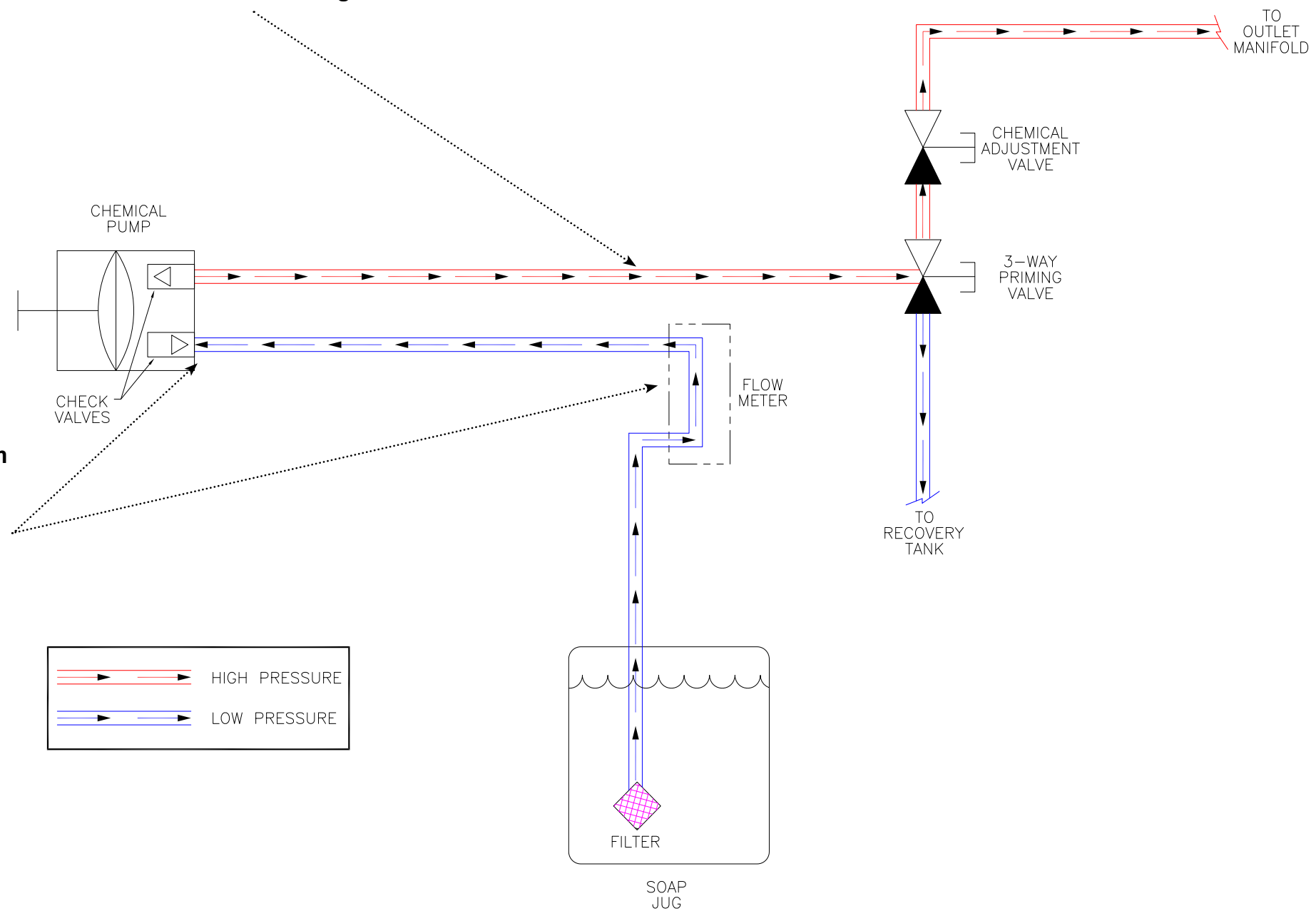

TITAN 575

Figure 6-4. Water, Chemical and Solution Flow Diagram - Larger View
7459

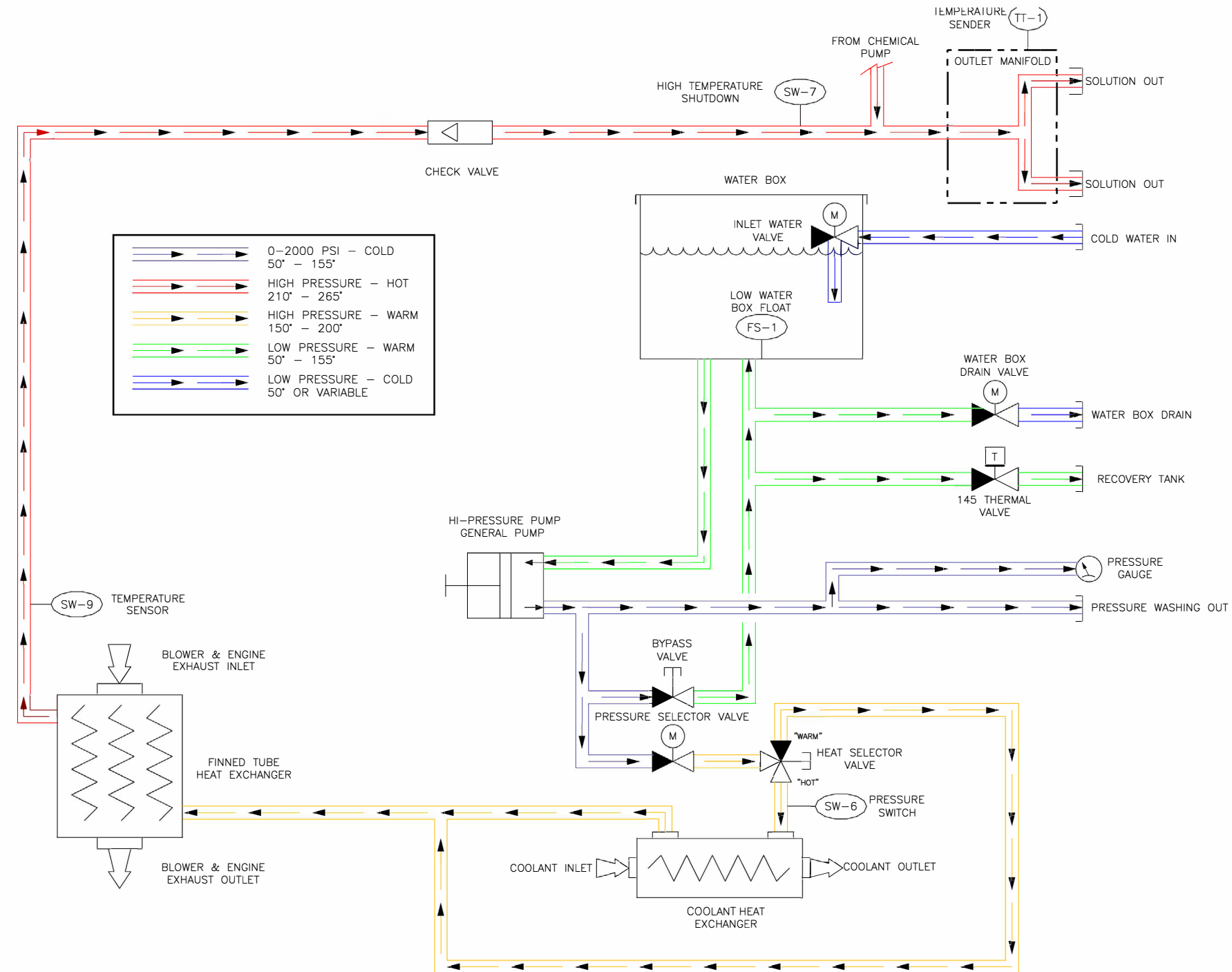
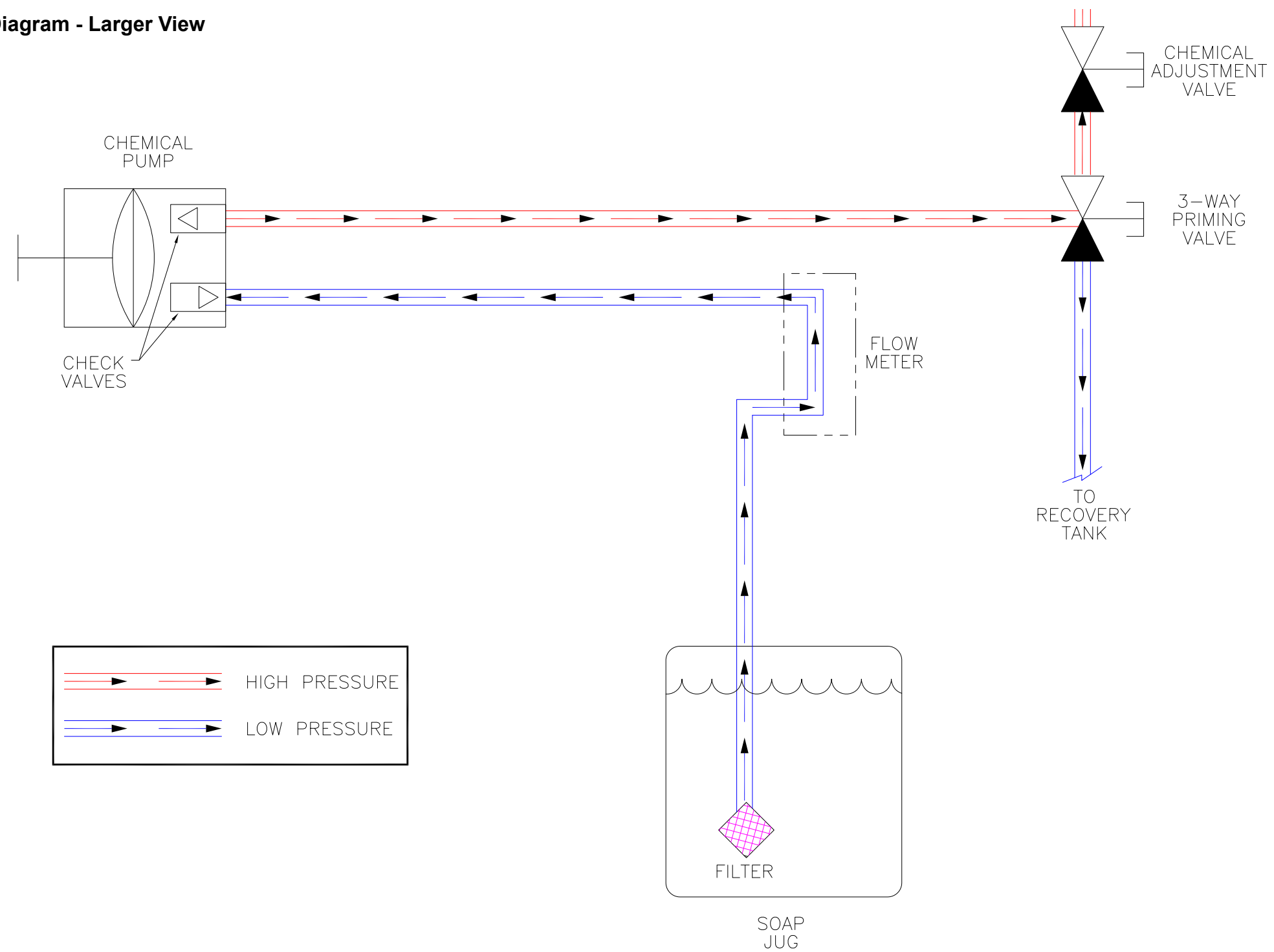
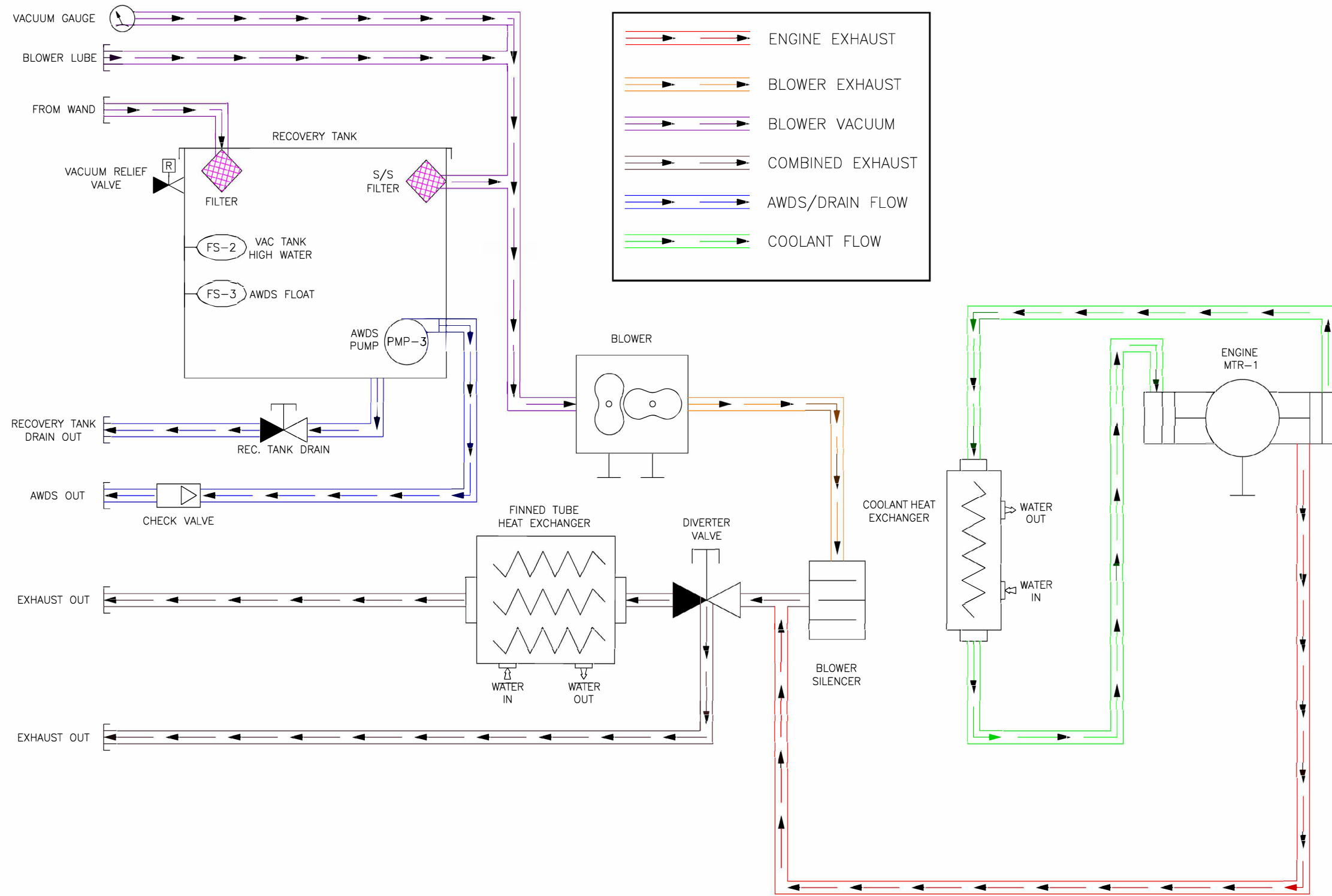

Figure 6-5. Chemical Flow Diagram - Larger View
7459



TITAN 575

Figure 6-6. Exhaust Flow Diagram
7459



7 - Electrical System

This section describes how the electrical system functions in the following manner:

- Electrical System Information
- Electrical Schematic
- Wiring Diagram

ELECTRICAL SYSTEM INFORMATION

The Titan 575 electrical system operates on 12 - 14 V DC which is provided by the battery. Battery levels are maintained by a 40-Amp alternator mounted on the engine.

NOTICE

When a new battery is installed, check that it is properly charged before installation or damage to the charging system may occur.

TITAN 575

Figure 7-1. Electrical Schematic
000-179-023 Rev. E

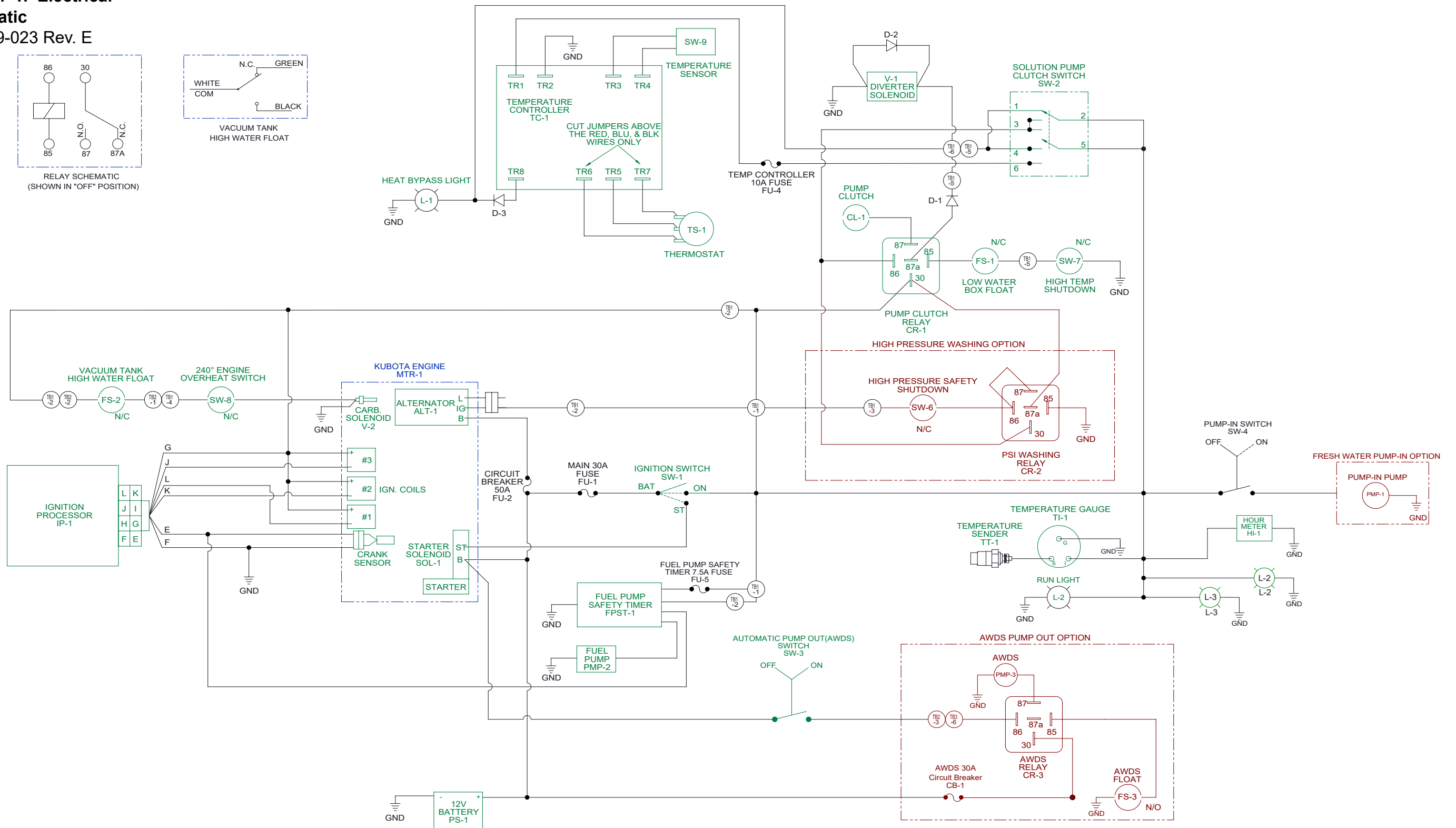

TITAN 575

Figure 7-2. Wiring Diagram - View 1 of 3
000-179-022 Rev. H

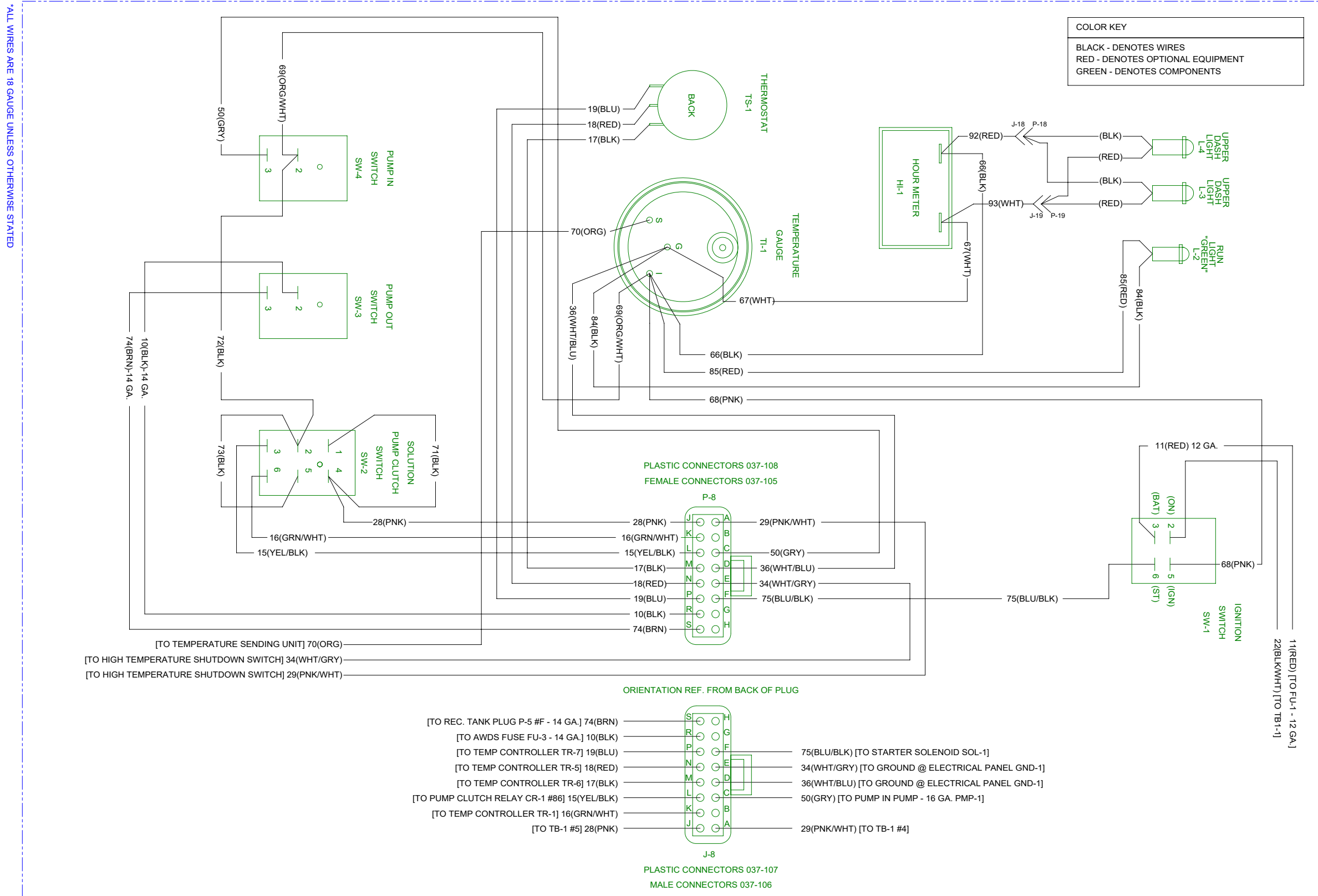

TITAN 575

Figure 7-3. Wiring Diagram - View 2 of 3
000-179-022 Rev. H

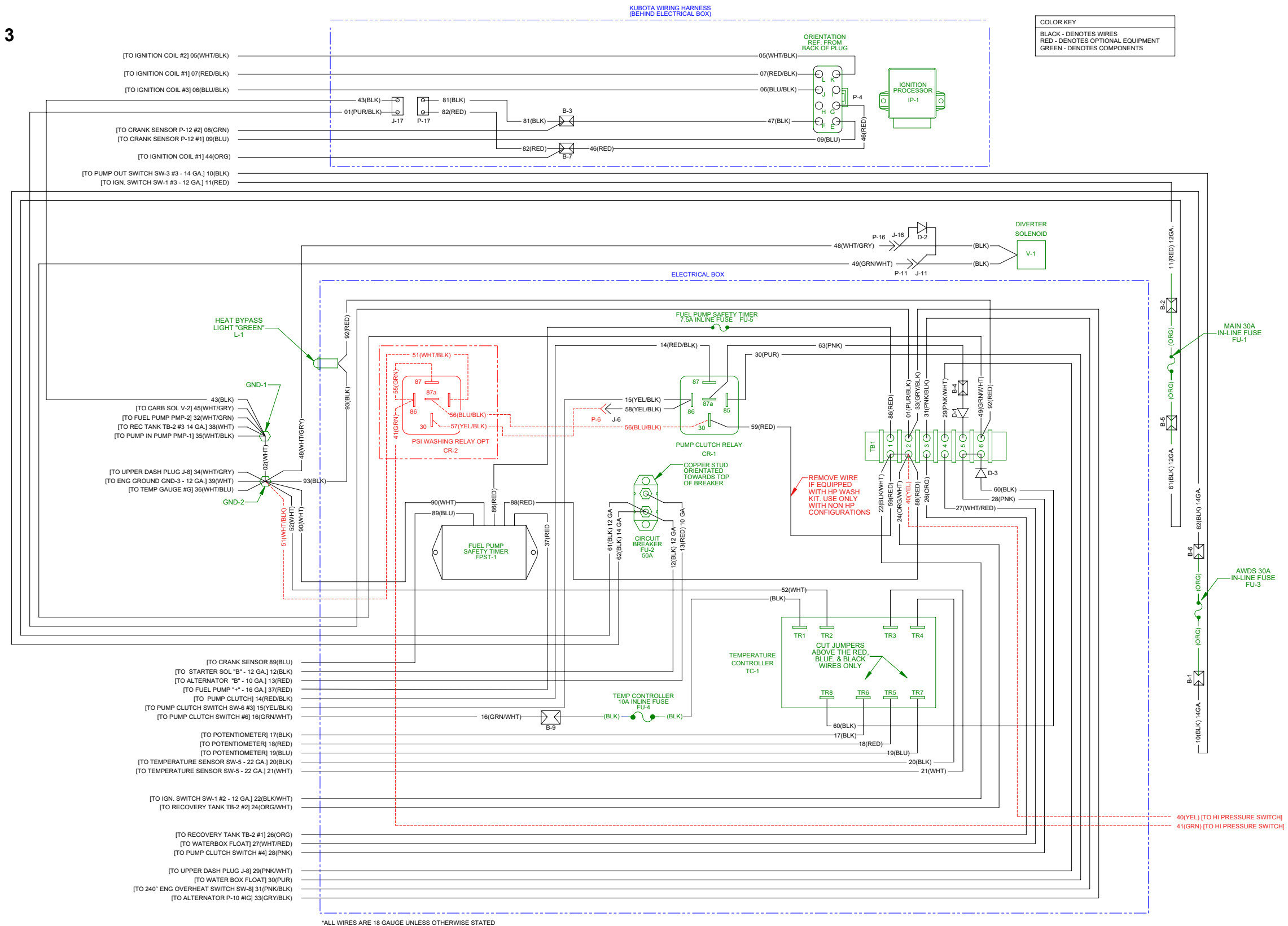

TITAN 575

Figure 7-4. Wiring Diagram -
View 3 of 3
000-179-022 Rev. H

COLOR KEY	
BLACK	- DENOTES WIRES
RED	- DENOTES OPTIONAL EQUIPMENT
GREEN	- DENOTES COMPONENTS

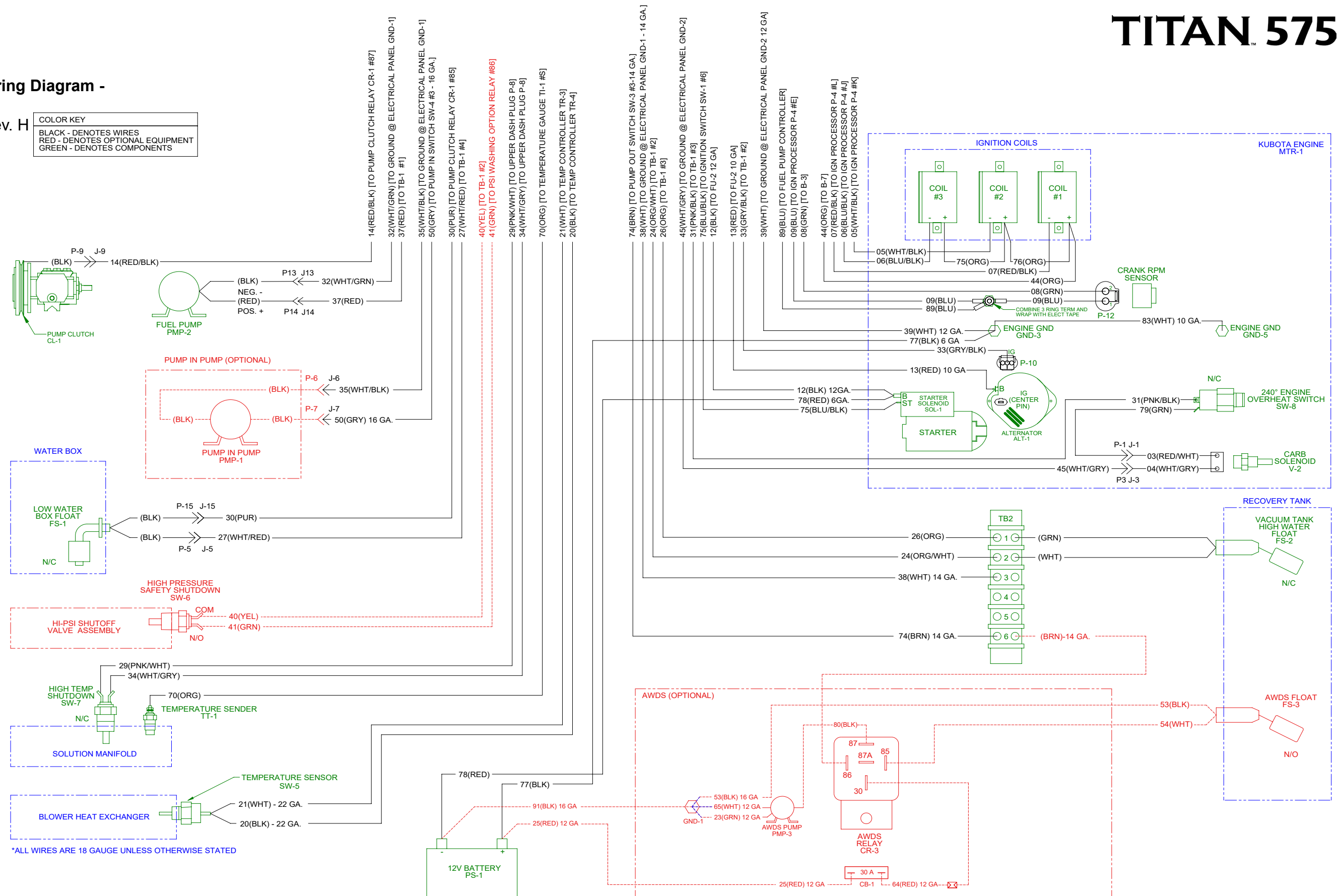

8 - Systems Troubleshooting

This section describes the standard troubleshooting procedures in the following areas:

- Heating System
- Chemical System
- Engine
- High Pressure System
- Vacuum System

TITAN 575

HEATING SYSTEM

1. The truckmount overheats and shuts down

Possible Cause	Solution
1.1. Faulty sensor	Inspect the engine overheat switch and test for functionality.

2. Unable to achieve normal cleaning solution temperature

Possible Cause	Solution
2.1. Temperature control knob is turned down.	Inspect the knob. Adjust if necessary.
2.2. The thermostatic valve is faulty.	Inspect the thermostatic valve and test for functionality.
2.3. Excessive solution flow at tool.	The cleaning tool jet is too large or worn. Inspect the jet. Replace if necessary.
2.4. The heat exchanger has hard water scale buildup.	Descale the system.
2.5. The heat exchanger has blockage on the inlet side.	Inspect the interior of heat exchanger. Remove the debris and clean as necessary.
2.6. The heat selector valve is in the wrong position.	Move the heat selector valve to the "HOT" position.

CHEMICAL SYSTEM

1. System will not prime

Possible Cause	Solution
1.1. The check valves in chemical pump are faulty.	Remove the valves and inspect. Clean or replace as necessary.
1.2. The chemical pump diaphragm is faulty.	Remove and inspect. Replace as necessary.
1.3. The check valve in high pressure pump is faulty (piston to which chemical pump is attached).	Remove the valve and inspect. Clean or replace as necessary.
1.4. The filter on feed line in chemical jug is clogged.	Inspect and clean.
1.5. The feed line from chemical jug is loose, pinched or damaged.	Inspect and repair.
1.6. The chemical selector valve is faulty.	Inspect the valve for leaks between ports. Replace as necessary.

2. Chemical flow is unstable or low

Possible Cause	Solution
2.1. Air is in the lines	Check that all fittings and connections are tight and in good condition. Repair or replace as necessary.
2.2. The filter screen in the chemical jug is partially obstructed.	Inspect and clean.
2.3. The chemical selector valve is faulty.	Inspect the valve for leaks between ports. Replace as necessary.
2.4. The chemical metering valve is faulty.	Remove and inspect the valve. Clean or replace as necessary.
2.5. The high pressure check valve is faulty.	Remove and inspect the valve. Clean or replace as necessary.

3. Chemical is present in water box

Possible Cause	Solution
3.1. The chemical pump diaphragm is faulty.	Remove and inspect the chemical pump diaphragm. Replace as necessary.
3.2. The high pressure check valve is faulty.	Remove and inspect the valve. Clean or replace as necessary.

TITAN 575

ENGINE

1. The engine will not turn over

Possible Cause	Solution
1.1. A loose or corroded battery terminal.	Clean and tighten the battery terminal connections.
1.2. The battery is dead.	Recharge or replace the battery. Test the charging system. Repair if necessary.
	CAUTION Do not attempt to jump start the truckmount from a running vehicle. The amperage output from an automobile will damage the charging system of the truckmount.
1.3. The main fuse is blown.	Check the main fuse.
	If the fuse is blown, inspect the electrical system for worn or shorted wires. Repair or replace as necessary.
1.4. The vacuum blower has seized.	Attempt to turn the coupler by hand. If it will not turn refer to the Vacuum System Troubleshooting Subsection (page 8-9).
1.5. The ignition switch is faulty.	Test to see if there is power both to and from the switch. Refer to the Electrical Section of this manual (page 7-1).
1.6. The starter solenoid is faulty.	Test to see if there is power to solenoid with ignition in "START" position. Refer to Electrical Section (page 7-1).
1.7. The starter motor is faulty.	Test to see if there is power to the motor with the ignition in "START" position. Refer to the Electrical Section (page 7-1).
1.8. None of the above.	Refer to a qualified service technician for further troubleshooting.

2. The engine turns over but will not start.

Possible Cause	Solution
2.1. The recovery tank is full	Drain the tank.
2.2. The recovery tank float is faulty.	Inspect the float. Repair or replace as necessary.
2.3. The engine ignition system is faulty.	Refer to a qualified service technician for further troubleshooting.
2.4. Fuel is not reaching the carburetor.	Test for power to the fuel pump. Refer to Electrical Section.
	If power is present, inspect the fuel pump. Replace if necessary.
	Inspect the fuel lines between the source and the carburetor. Repair or replace as necessary.
2.5. The engine is flooded.	Remove spark plug and dry.
2.6. The spark plugs are worn or dirty.	Inspect and replace as necessary.
2.7. None of the above.	Refer to a qualified service technician for further troubleshooting.

NOTICE

Engine should be adjusted to run at 3,000 rpm under a vacuum load of 12" Hg.

3. The Engine will not come up to normal operating rpm

Possible Cause	Solution
3.1. Excessive load on the engine.	Inspect and clean the recovery tank filters.
	Inspect the recovery tank to the blower hose. Repair or replace as necessary.
3.2. Excessive back pressure on the engine exhaust.	Inspect for blockage in the heat exchanger. Clean or replace as necessary.

TITAN 575

4. Runs rough at high speed

Possible Cause	Solution
4.1. The spark plug(s) are faulty.	Remove and inspect the plugs. Clean or replace as necessary.
4.2. The spark plug wire(s) are faulty.	Inspect the wires and connectors for damage or loose connections. Repair or replace as necessary.
4.3. Inadequate fuel supply to the carburetor.	Check for blockage in the filter. Repair or replace as necessary.
4.4. Poor connection to coils.	Verify there is a good contact with each of the wires to the coils.

5. Runs rich (black smoke)

Possible Cause	Solution
5.1. A dirty air filter	Inspect and replace as necessary.
5.2. Excessive back pressure	Inspect for a clogged heat exchanger, dirty air filter or a partially opened choke.

6. Engine overheats

Possible Cause	Solution
6.1. Poor ventilation in the van	Open all the van doors.
	Install a roof vent in the van.
	Remove any dividers or other objects impeding airflow around the truckmount.
6.2. Low oil level	Check the level and fill as necessary.
6.3. Excessive back pressure on the engine exhaust	Inspect for blockage in the heat exchanger. Clean or replace as necessary.
6.4. Low coolant	Check radiator level
	Check overflow bottle level
6.5. Poor coolant mixture	Check the coolant with a test to determine mixture; adjust as necessary.

HIGH PRESSURE SYSTEM

1. The pump will not come up to normal cleaning pressure

Possible Cause	Solution
1.1. The pressure adjusting valve is faulty.	Inspect the valve. Repair or replace if necessary.
1.2. Worn seals or valves in the pump.	Test the pump output volume directly from the pump at normal running rpm. If the volume is below the manufacturer's specifications, replace the seals and inspect for defective valves.
1.3. The pump rpm is too low.	Check for a loose pump belt. Adjust or replace as necessary.
	Check the engine rpm and adjust as necessary to 3,000 rpm under a 12" Hg vacuum load.

2. No pressure reading on gauge

Possible Cause	Solution
2.1. The pump belt is broken.	Inspect and replace if necessary.
2.2. The gauge is faulty.	Replace the gauge.

3. The psi gauge reads normal (low pressure from wand)

Possible Cause	Solution
3.1. Restriction in the cleaning tool	Inspect the tool jet(s) and clean or replace as necessary.
	Inspect any filters in the cleaning tool and clean or replace as necessary.
3.2. Faulty quick connect in the system	Inspect each quick connect and replace as necessary.
3.3. Restriction in one of the solution hoses	Remove the quick connects and inspect hoses. Clean or replace as necessary.
3.4. Hard water deposits restricting the system	Descale the truckmount.

TITAN 575

4. Pressure pulsation

Possible Cause	Solution
4.1. Chemical pump is not primed.	Prime the chemical pump.
4.2. Air leak between the water box and pump.	Check all the hoses and fittings for cuts, breaks, cracks, etc. Repair as necessary.
4.3. The check valve(s) in the pump are faulty.	Remove each valve and inspect for correct operation. See Machine Maintenance (Section 5).

5. Water box empty or fills slowly

Possible Cause	Solution
5.1. Restriction in the water supply system.	Inspect the supply system from the source through the incoming quick connect.
5.2. The float valve in the water box is faulty.	Disassemble and inspect the valve. Repair or replace as necessary.

6. The water box overflows

Possible Cause	Solution
6.1. The float valve in the water box is faulty.	Disassemble and inspect the valve. Repair or replace as necessary.
6.2. The float has absorbed water and lost buoyancy.	Replace as necessary.
6.3. The float has come out of adjustment.	Adjust the float as necessary.

VACUUM SYSTEM

1. Weak vacuum at wand. The gauge reads normal.

Possible Cause	Solution
1.1. Blockage in the hoses or wand tube	Disconnect the hoses and check for an obstruction.
1.2. Excessive length of hose connected to the truckmount	Do not attach excessive lengths of hose.

2. Weak vacuum

Possible Cause	Solution
2.1. Air leak somewhere in the vacuum system	Check the vacuum relief valve for proper adjustment.
	Carefully check all the vacuum hoses for a cut or break.
	Check the recovery tank lid gasket.
	Make sure the recovery tank drain valve is fully closed.
2.2. The vacuum blower is turning too slowly.	Check the rpm of the engine. Adjust as necessary to 3,000 rpm under a 12" Hg. vacuum load.
2.3. The vacuum gauge is defective.	Test the gauge and replace if necessary.

3. The vacuum gauge reads too high with no hoses attached

Possible Cause	Solution
3.1. The filter in recovery tank is clogged.	Remove and clean or replace as necessary.
3.2. The hose from recovery tank to the vacuum blower is collapsed internally.	Inspect and replace as necessary.

4. Excessive noise produced by the blower

Possible Cause	Solution
4.1. The blower is low on oil.	Inspect the oil levels and replenish as necessary. Note: Running the blower with low oil levels can cause severe damage. If this situation occurs the blower should be inspected by a qualified service technician.
4.2. The vacuum blower has internal damage.	Refer to a qualified service technician.

TITAN 575

5. The vacuum blower is locked and will not turn

Possible Cause	Solution
5.1. Truckmount has been inactive for a period of time and the blower was not properly lubricated prior to final shutdown. Rust has possibly built up on the internal surfaces.	Spray penetrating oil into the blower and let sit for at least one hour. Then very carefully use pipe wrench on the outer diameter of the pulley on the coupler to attempt to free lobes of the blower. Do not use a wrench directly on the blower shaft. If unable to free up the blower in this manner, refer to a qualified service technician.
5.2. There is internal damage to the blower	Refer to a qualified service technician.

6. Water in truckmount exhaust

Possible Cause	Solution
6.1. The recovery tank has been filled with foam or overfilled with water.	Inspect the recovery tank. If full, drain the tank.
	Inspect the high level shutoff switch for proper operation. Clean or replace the switch as necessary.
	If foam is in recovery tank, use defoamer on the carpet being cleaned.
6.2. Condensation in system	This will be more common in cool weather and humid climates. If this is the cause it should dissipate after a few minutes of running.
6.3. The heat exchanger is leaking water.	Inspect and repair or replace as necessary.

9 - Assemblies and Parts Lists

This section of the manual provides detailed illustrations and parts lists for the following assemblies.

NOTICE

When ordering parts for assemblies, first refer to the appropriate assembly listed here and then find the part number listed on that specific page. In most cases, you do not have to order the entire assembly to get a part.

If you have an electronic copy (a .pdf) of this manual, you can search for the part number by pressing the **CTRL** key and the **F** key at the same time. This will “pop up” the Find window on your monitor. Type the part number, including dashes, into the Find window and press the **Enter** key.

■ Console Assembly Parts List	9-7	■ Diverter Valve Assembly Parts List	9-42
■ Frame Assembly Parts List	9-9	■ Chemical Jug Tray/Hose/Connection Assembly Parts List	9-43
■ Engine Assembly Parts List	9-14	■ Chemical Jug Tray Assembly Parts List	9-44
■ Exhaust Assembly Parts List	9-15	■ By-Pass Valve Assembly Parts List.....	9-46
■ Top Cover Assembly Parts List	9-16	■ 3-Way Valve Assembly Parts List	9-47
■ Fly Wheel Plate Assembly Parts List	9-18	■ Actuator Valve Assembly Parts List	9-48
■ Upper Dash Assembly Parts List	9-20	■ Hi Pressure Manifold Assembly Parts List	9-49
■ Electrical Panel Assembly Parts List	9-23	■ Differential Check Valve Assembly Parts List	9-50
■ Blower Assembly Parts List	9-25	■ 70 Gallon Universal Recovery Tank (URT) Assembly Parts List	9-52
■ Pump and Silencer Assembly Parts List.....	9-26	■ 70 Gallon Universal Recovery Tank (URT) Cover Assembly Parts List	9-54
■ Pump Assembly Parts List	9-29	■ 100 Gallon Universal Recovery Tank (URT) Assembly Parts List	9-56
■ Water Box Assembly Parts List	9-31	■ 100 Gallon Universal Recovery Tank (URT) Cover Assembly Parts List	9-58
■ Diffuser Filter Assembly Parts List	9-32	■ Vacuum Relief Valve Assembly Parts List	9-59
■ Frame Assembly Parts List	9-31	■ Vacuum Inlet Stopper Assembly Parts Lis	9-60
■ Lower Dash Assembly Parts List	9-35	■ AWDS Universal Kit Assembly Parts List	9-62
■ Side Cover - Console Assembly Parts List	9-36	■ High Pressure Washing Kit Assembly Parts List	9-64
■ Blower Heat Exchanger Assembly Part List	9-39	■ High Pressure Washing Kit Assembly Parts List	9-65
■ Coolant Heat Exchanger Assembly Parts List	9-41	■ Sacrificial Anode Kit Assembly Parts List	9-66

Figure 9-2. Console Assembly - View 1 of 4
610-050-753 Rev. C

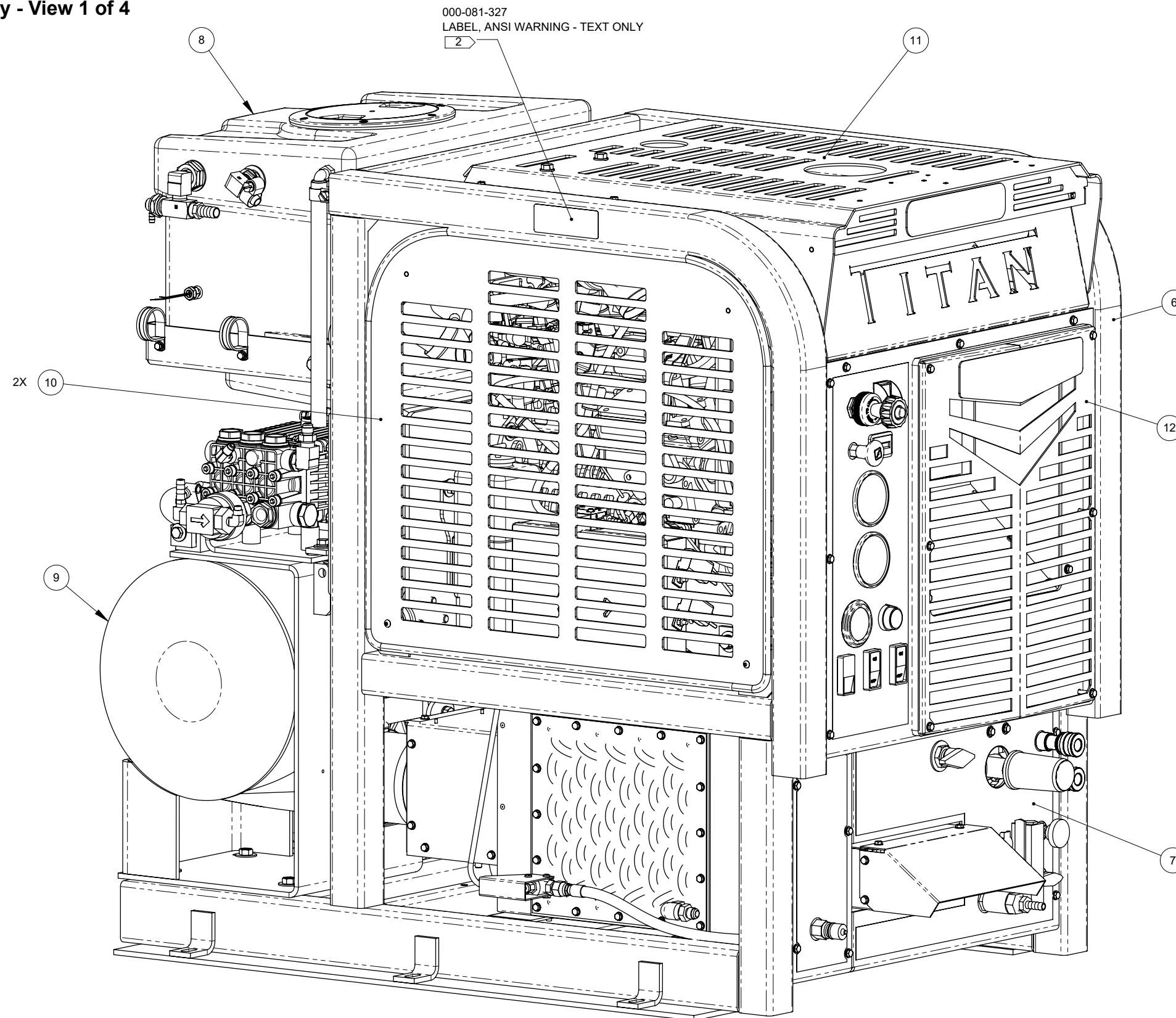

TITAN 575

Figure 9-3. Console Assembly - View 2 of 4
610-050-753 Rev. C

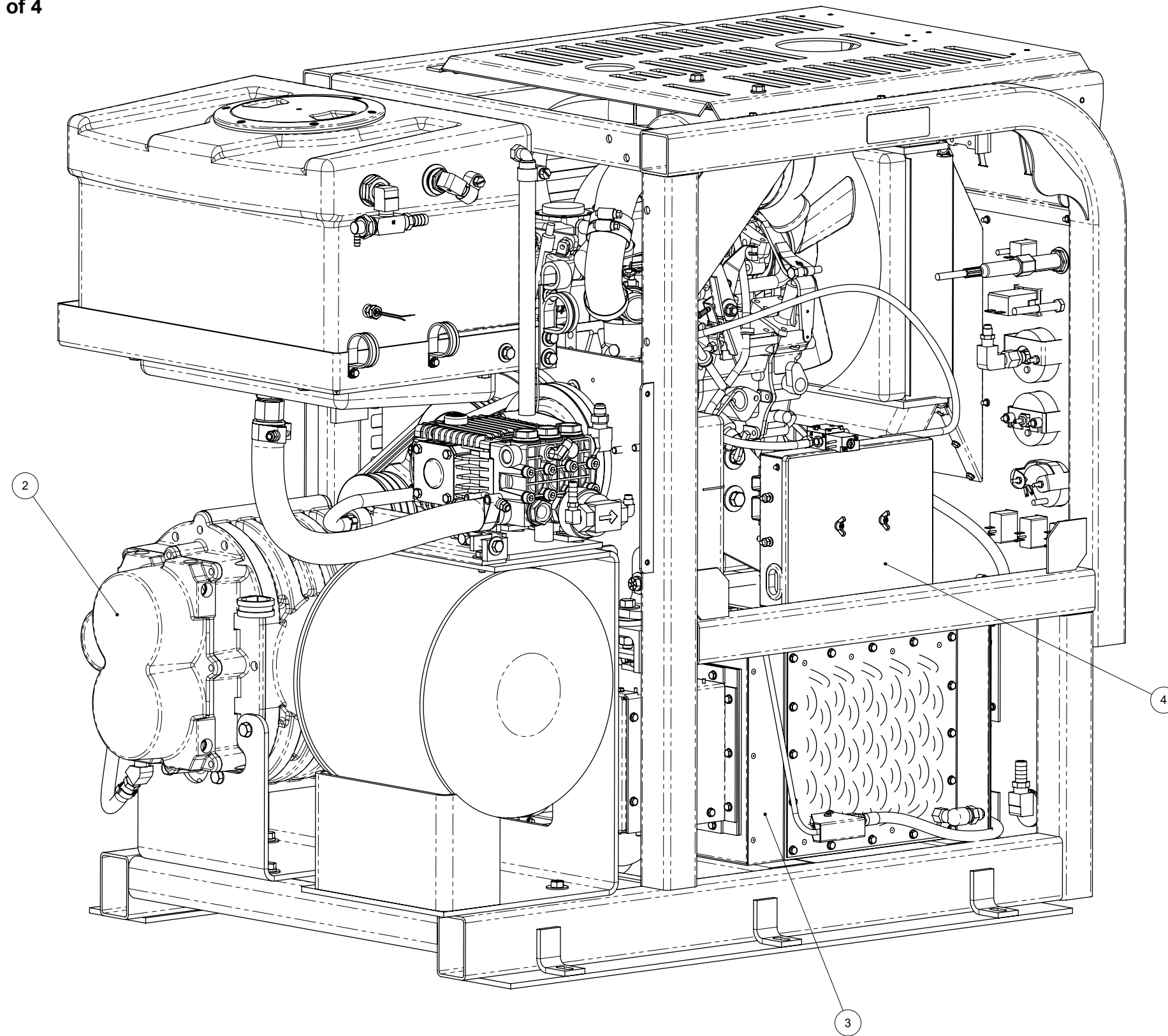

SOME HOSES AND EXTERNAL PARTS HIDDEN FOR CLARITY

Figure 9-4. Console Assembly - View 3 of 4
610-050-753 Rev. C

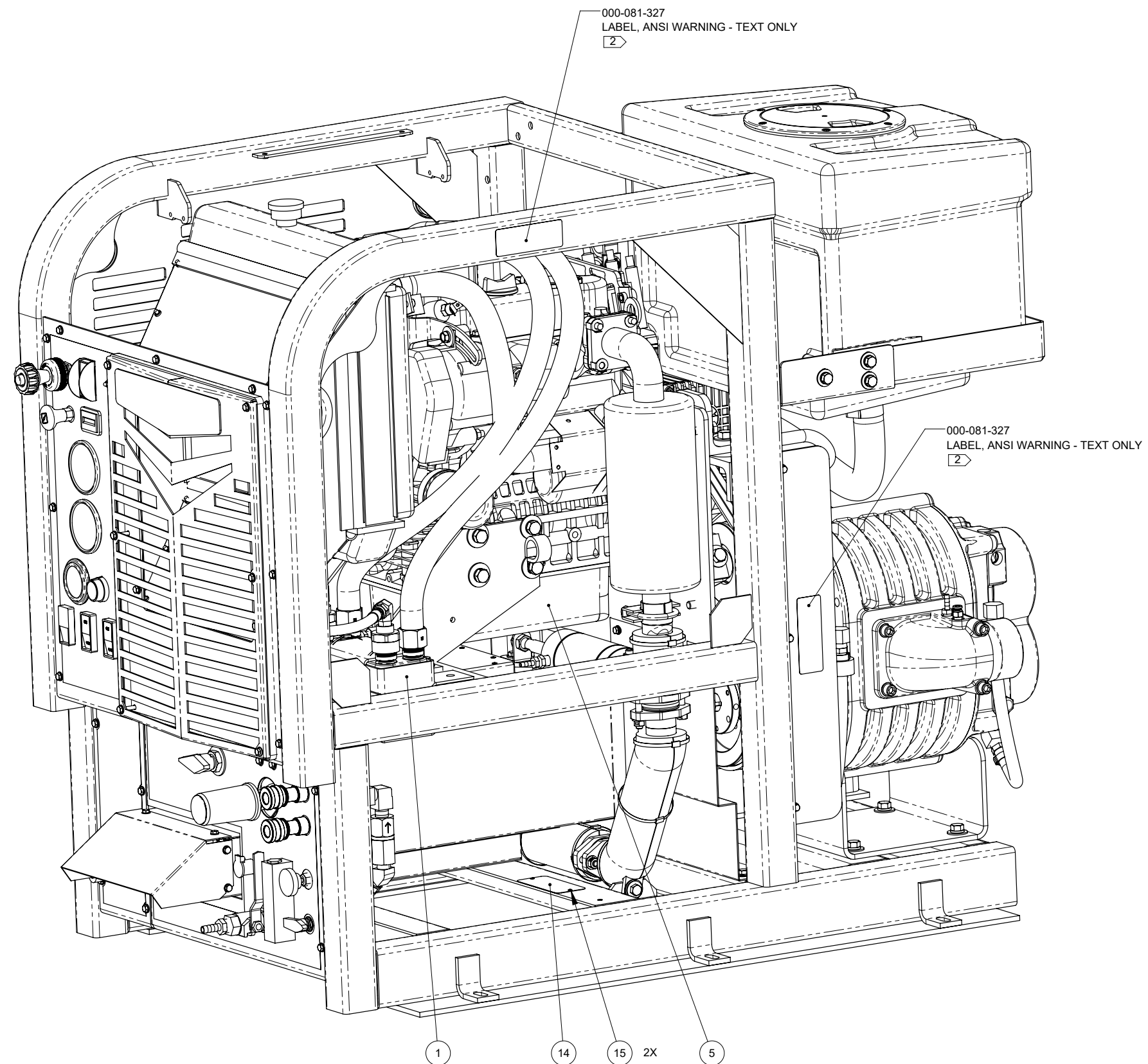

TITAN 575

Figure 9-5. Console Assembly - View 4 of 4
610-050-753 Rev. C

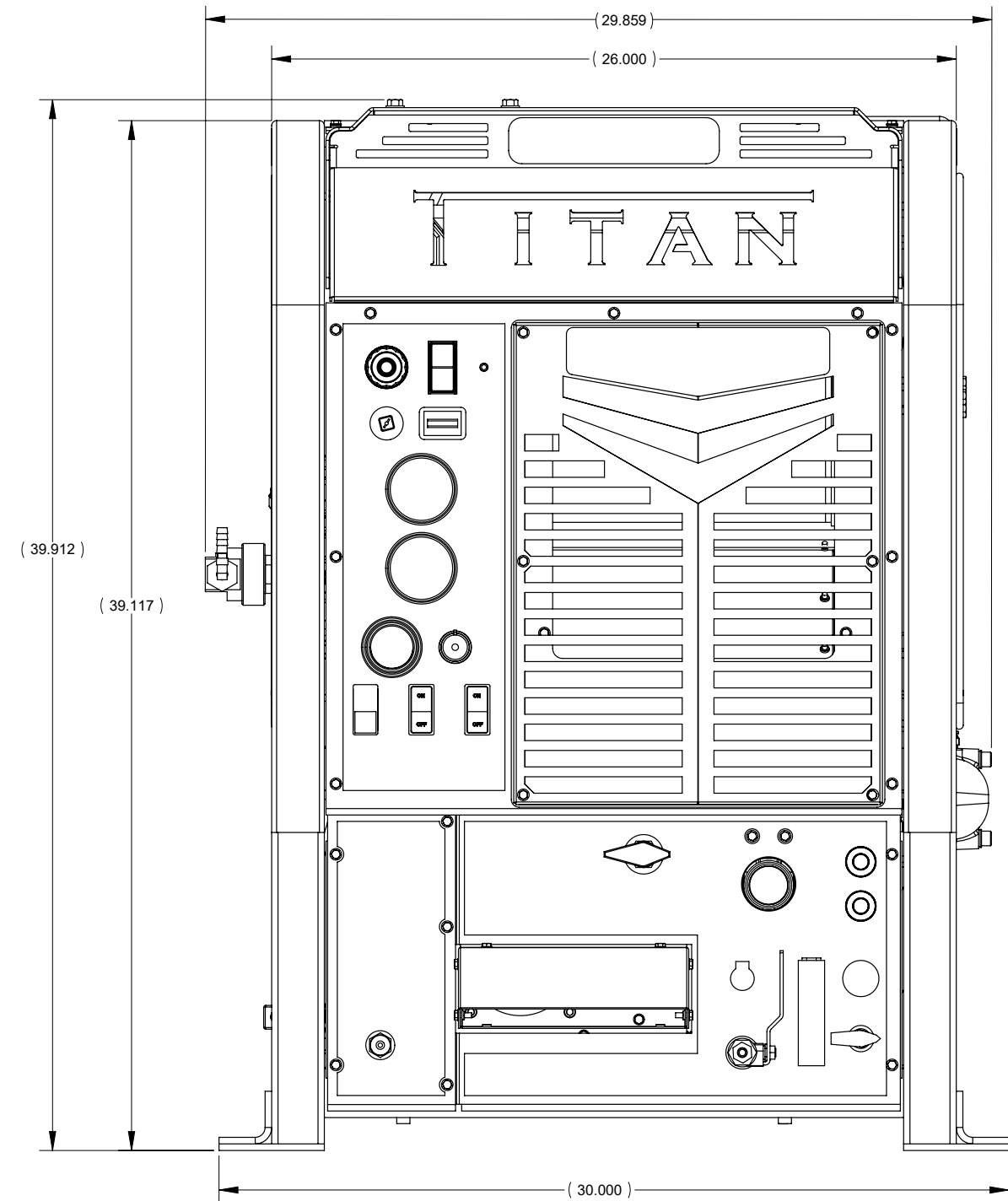
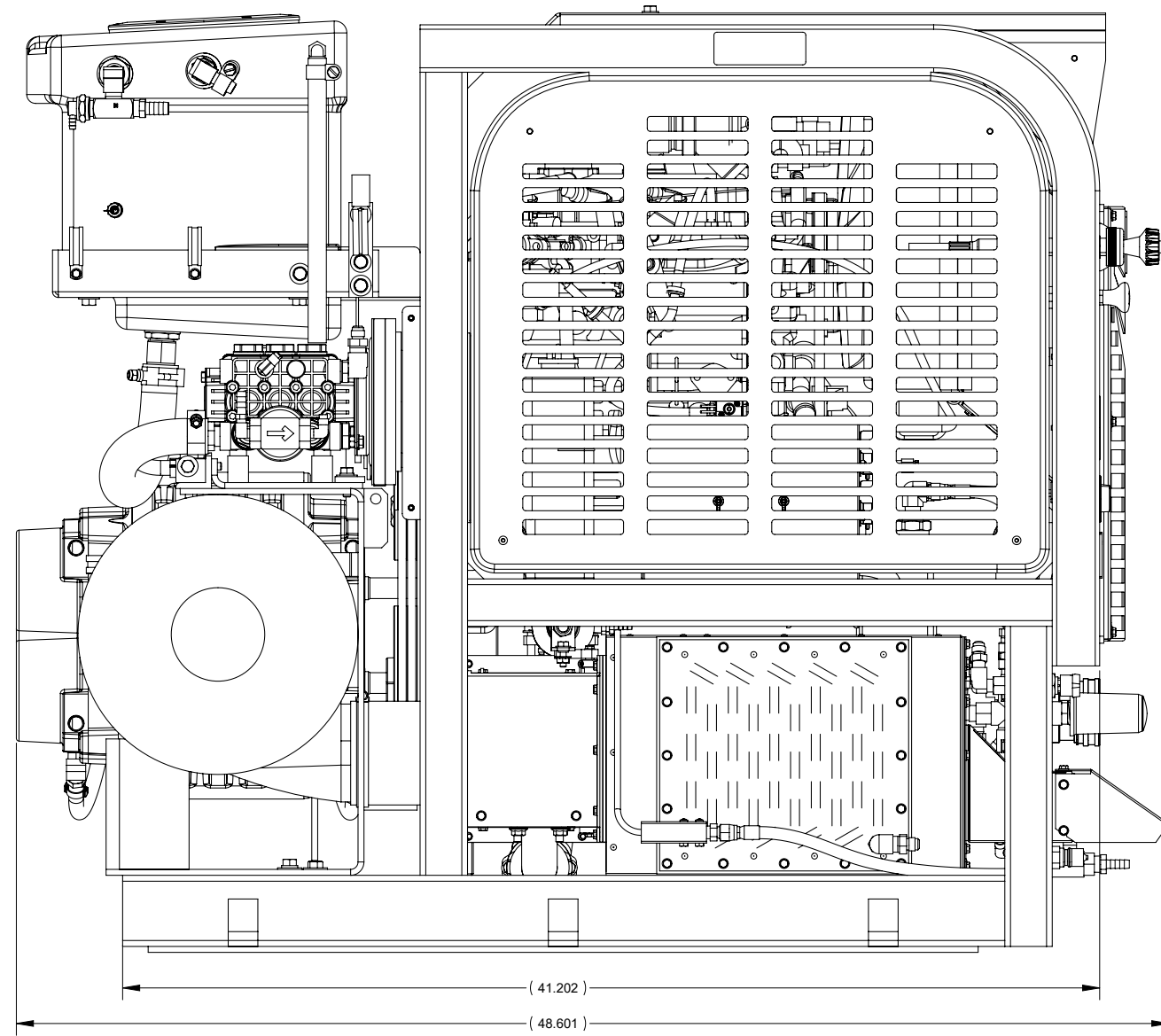

TITAN 575

Console Assembly Parts List

Item	Part Number	Description	Qty
1	610-006-743	ASSEMBLY, ALFA LAVAL AXP14 - 575	1
2	610-002-741	ASSEMBLY, BLOWER	1
3	610-005-741	ASSEMBLY, BLOWER HEAT EXCHANGER	1
4	610-011-741	ASSEMBLY, ELECTRICAL PANEL	1
5	610-004-741	ASSEMBLY, ENGINE - KUBOTA	1
6	610-001-741	ASSEMBLY, FRAME	1
7	610-019-753	ASSEMBLY, LOWER DASH - TITAN 575 2019	1
8	610-010-741	ASSEMBLY, POLY WATER BOX 8G	1

Item	Part Number	Description	Qty
9	610-021-741	ASSEMBLY, PUMP & SILENCER	1
10	610-023-744	ASSEMBLY, SIDE COVER - MACHINE - E10	2
11	610-022-753	ASSEMBLY, TOP COVER - TITAN 575 2019	1
12	610-020-753	ASSEMBLY, UPPER DASH - TITAN 575 2019	1
13	000-081-515	LABEL SET, TITAN 575 2019	1
14	000-105-012	PLATE, MACHINE SERIAL I.D.	1
15	000-140-001	RIVET, AB4-3A ALUMINUM POP 1/8" x 1/4" LG. (GRIP RANGE 0.126" - 0.187")	2



TITAN 575

Figure 9-6. Frame Assembly
610-001-741

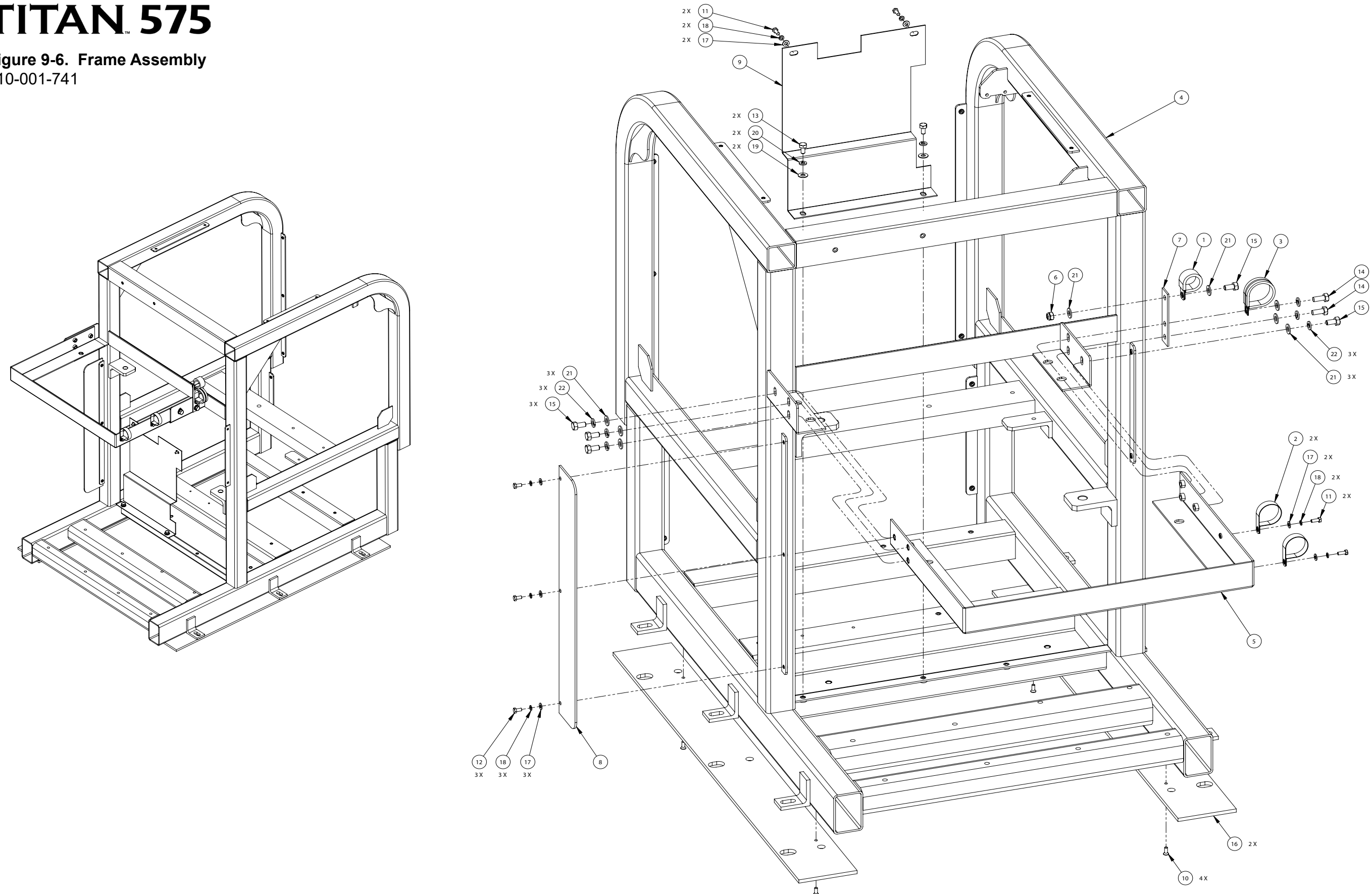

Frame Assembly Parts List

Item	Part Number	Description	Qty
1	000-033-117	Clamp, 1" Cushion Loop w/ 7/16 Mount Hole	1
2	000-033-053	Clamp, 1-1/2" Cushion Loop	2
3	000-033-135	Clamp, 1-3/4" Cushion Loop w/ 7/16" Hole	1
4	000-055-190	Frame - Coated	1
5	000-092-032	Mount, Water Box Support - Coated	1
6	000-094-038	Nut, 5/16"-18UNC Nylock	1
7	000-105-564	Plate, Fuel Hose Support	1
8	000-108-150	Protector, Belt Guard - Coated	1
9	000-108-164	Protector, Belt Heat Shield	1
10	000-143-114	Screw, #10-24UNC X 0.50" Lg. Flat Head Phillips	4
11	000-143-126	Screw, #10-24UNC X 0.50" Lg. Hex Head	4

Item	Part Number	Description	Qty
12	000-143-166	Screw, #10-24UNC X 3/8" Lg. Hex Head	3
13	000-143-333	Screw, 1/4"-20UNC X 0.50" Lg. Hex Head	2
14	000-143-012	Screw, 5/16"-18UNC X 3/4" Lg.	2
15	000-143-572	Screw, 5/16-18UNC X 5/8" Lg. Grd. 5 Hex Head	5
16	000-154-156	Spacer, Machine Rising 4" X 35"	2
17	000-174-001	Washer, #10 Flat	7
18	000-174-014	Washer, #10 Lock	7
19	000-174-003	Washer, 1/4" Flat	2
20	000-174-019	Washer, 1/4" Lock	2
21	000-174-004	Washer, 5/16" Flat	8
22	000-174-018	Washer, 5/16" S/S Lock	6

TITAN 575

Figure 9-7. Engine Assembly -
View 1 of 4

610-004-741 Rev. J

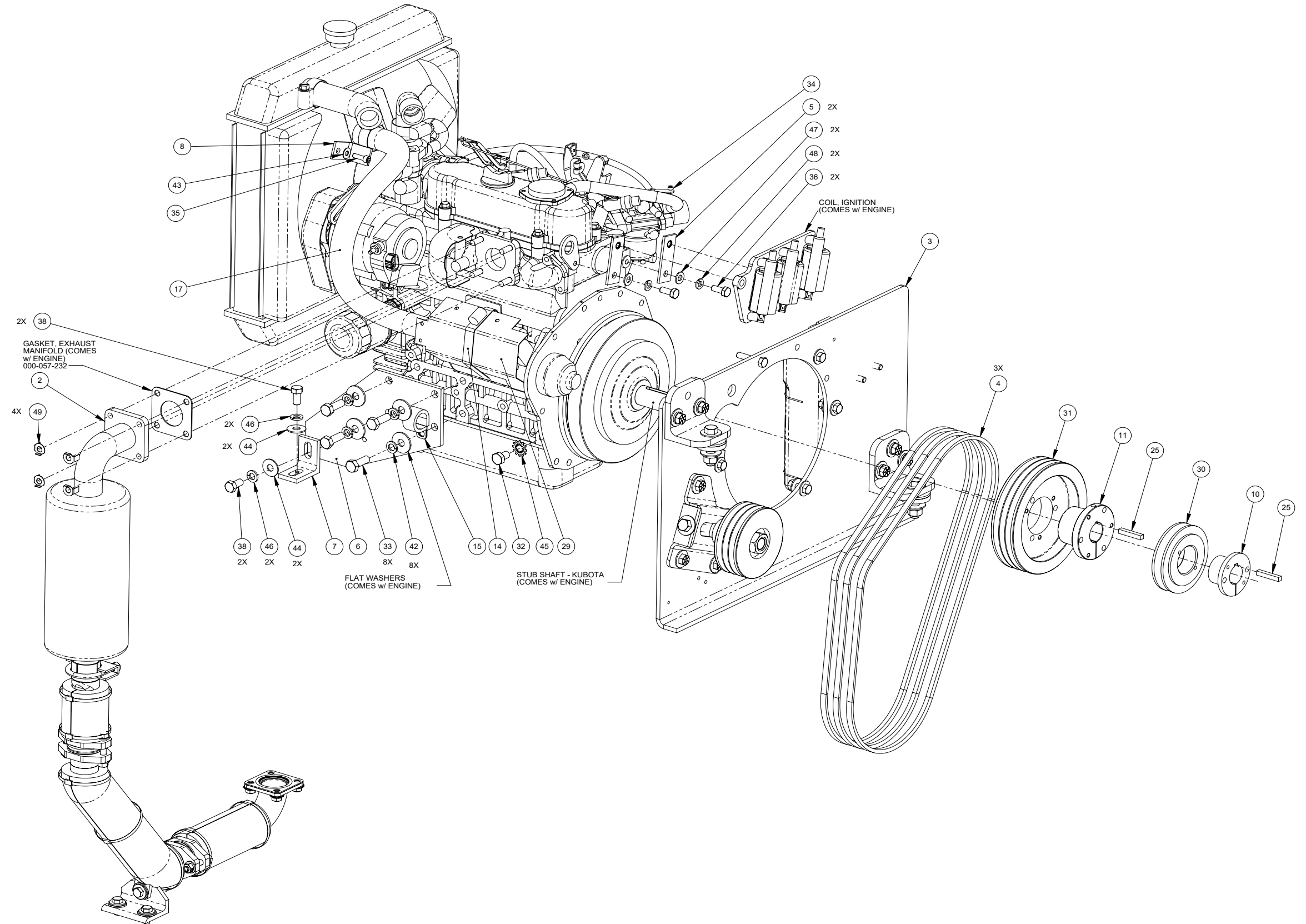
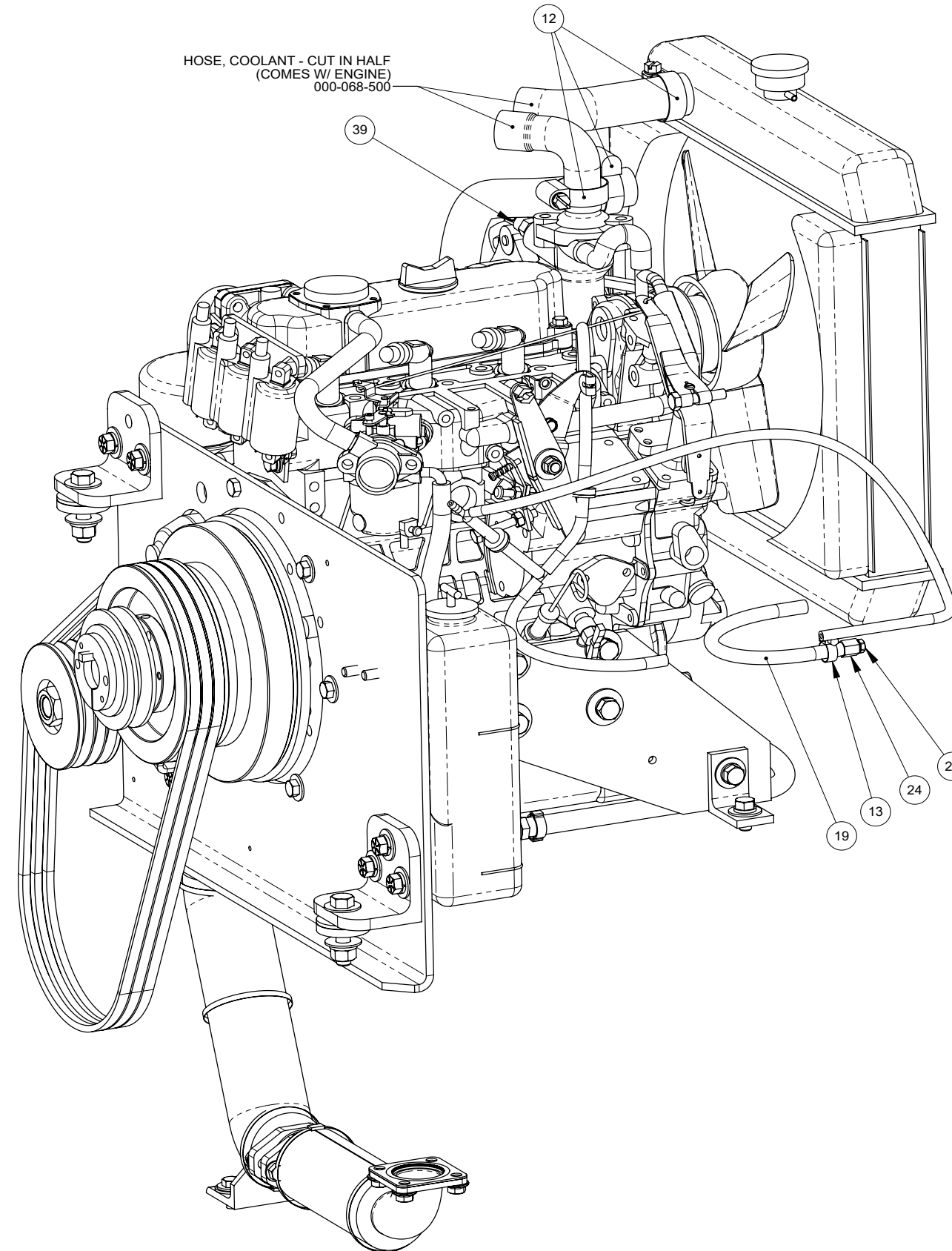

Figure 9-8. Engine Assembly - View 2 of 4
610-004-741 Rev. J



TITAN 575

Figure 9-9. Engine Assembly - View 3 of 4
610-004-741 Rev. J

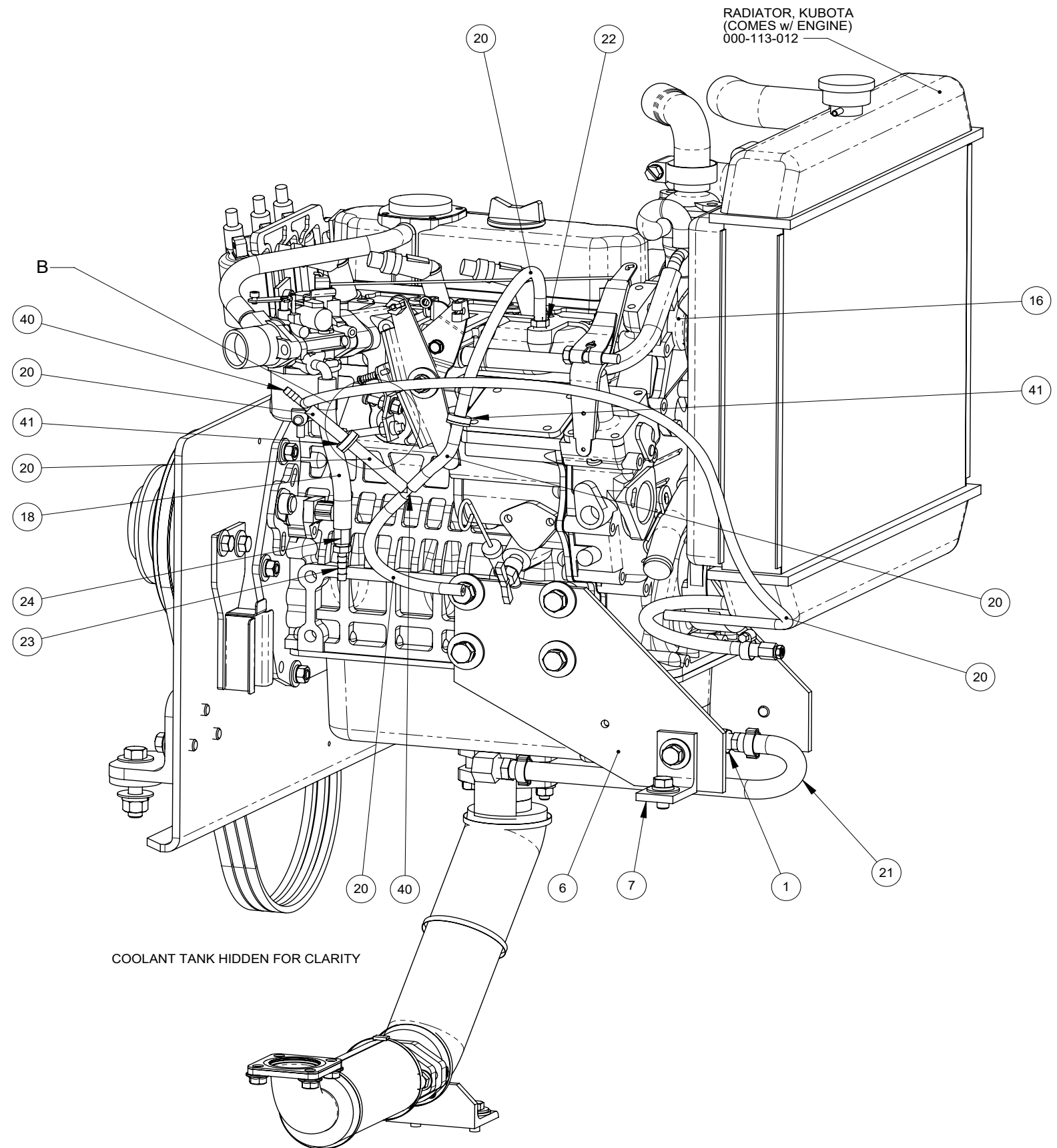
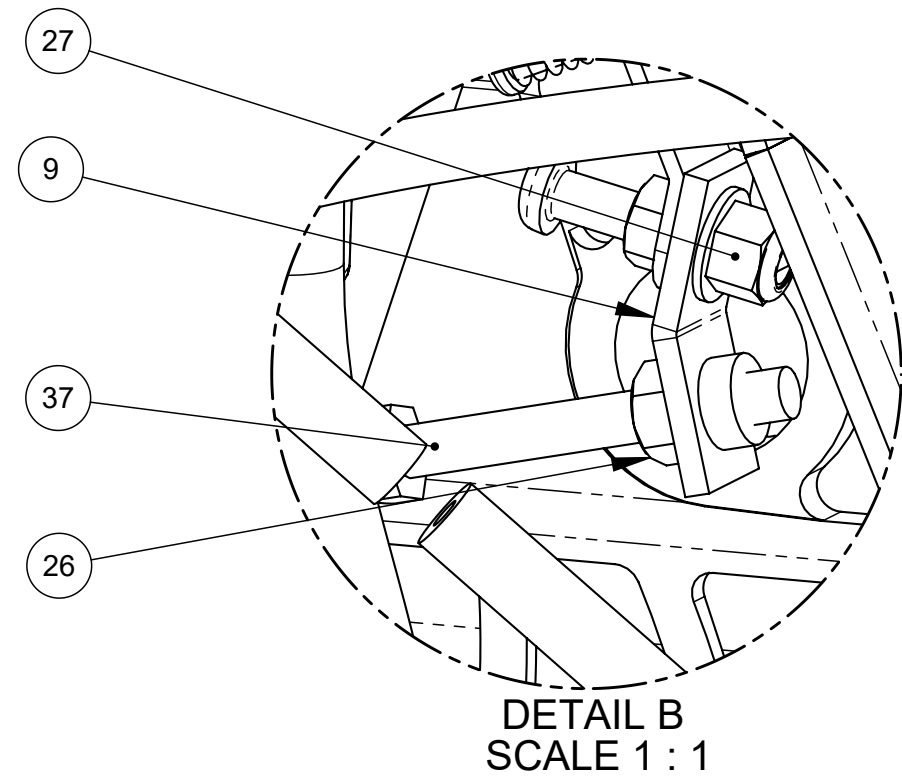
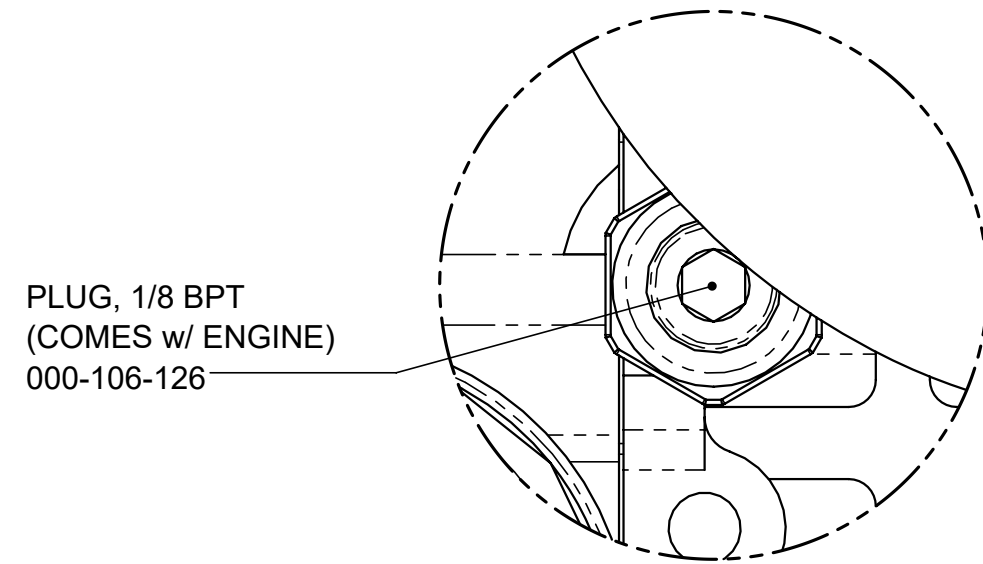
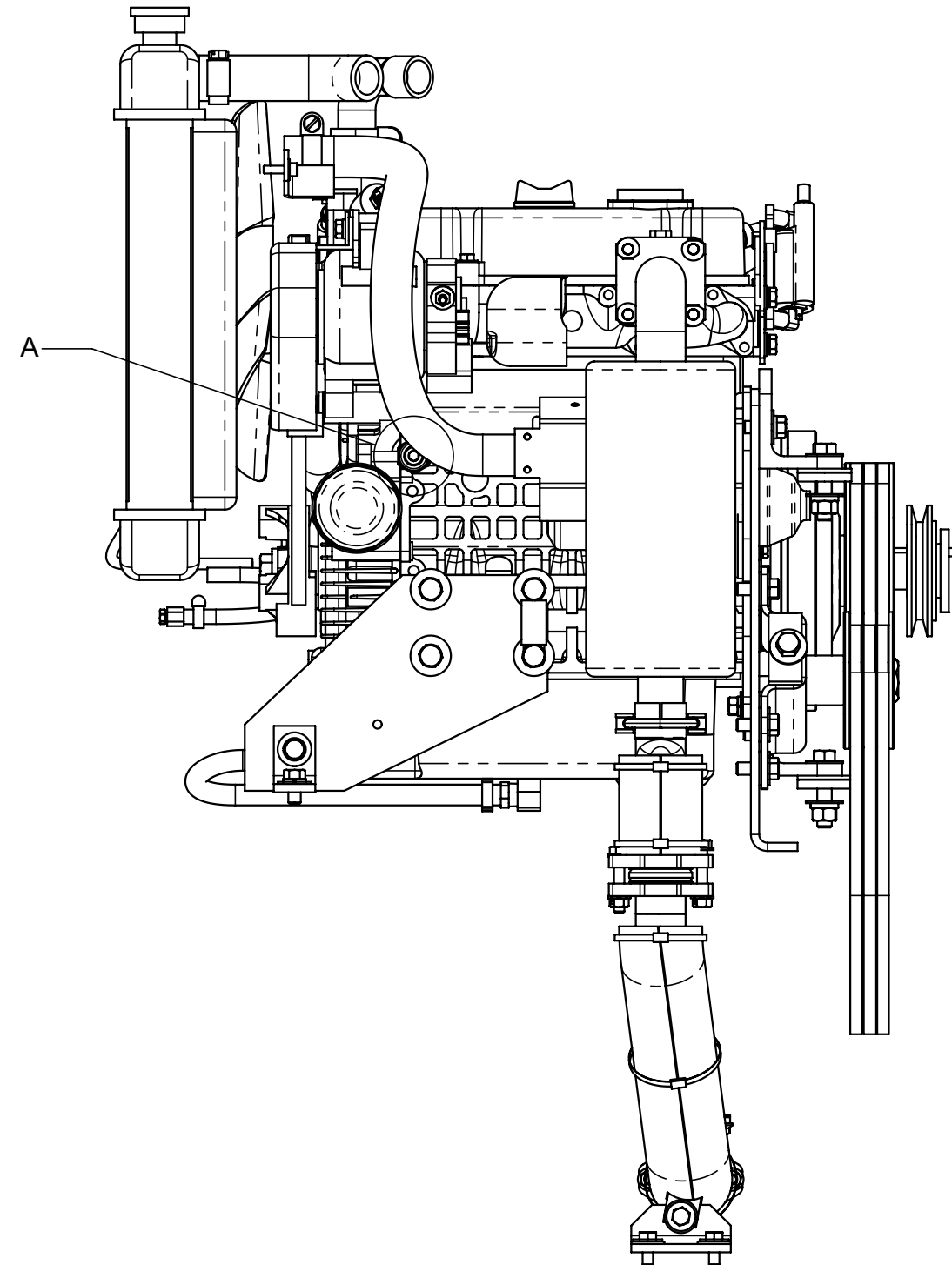

Figure 9-10. Engine Assembly - View 4 of 4
610-004-741 Rev. J



DETAIL A
SCALE 1 : 1



TITAN 575

Engine Assembly Parts List

Item	Part Number	Description	Qty	Item	Part Number	Description	Qty
1	000-052-906	ADAPTER, 1/4" F X 12MM MALE	1	26	000-094-008	NUT, 1/4"-20UNC HEX Z/P	1
2	610-013-741	ASSEMBLY, EXHAUST	1	27	000-094-125	NUT, 6MM HEX NYLOCK FLANGE S/S	1
3	610-021-007	ASSEMBLY, FLYWHEEL PLATE	1	28	000-106-126	PLUG, 1/8" BPT (BRITISH PIPE THREAD)	1
4	000-010-131	BELT, 3VX450 SUPER HC	3	29	000-108-165	PROTECTOR, STARTER	1
5	000-015-1032	BRACKET, ENGINE, COIL RELOCATION	2	30	000-109-040	PULLEY, AK47-H	1
6	000-015-1052	BRACKET, ENGINE, FRONT - COATED	2	31	000-109-124	PULLEY, Ø6.5" O.D. TRI-3VX SECTION	1
7	000-015-265	BRACKET, MACHINE TIE DOWN - COATED	2	32	000-143-714	SCREW, M10 X 1.25 X 16MM HEX HEAD Z/P	1
8	000-015-1167	BRACKET, STARTER COOLING HOSE	1	33	000-143-710	SCREW, M10 x 1.5 x 30MM LG.	8
9	000-015-1245	BRACKET, THROTTLE STOP	1	34	000-143-713	SCREW, M4 X 8MM SOCKET HEAD	1
10	000-020-055	BUSHING, HQ 1-1/8	1	35	000-143-077	SCREW, M6 X 1 X 20MM LG. SOCKET HEAD	1
11	000-020-070	BUSHING, QD SDS STYLE	1	36	000-143-185	SCREW, M8 x 1.25 X 20MM GR. 8.8 HEX HEAD	2
12	000-033-020	CLAMP, SIZE #16 HOSE	3	37	000-143-548	SCREW, 1/4"-20UNC x 2.00" LG. HEX HEAD	1
13	000-033-003	CLAMP, SIZE #4 MINI HOSE	1	38	000-143-017	SCREW, 3/8"-16UNC x 0.75" LG. HEX HEAD GRD. 8	4
14	000-033-060	CLAMP, SIZE #80 HOSE	1	39	000-149-545	SENSOR, 240°F N/C DAIHATSU	1
15	000-033-117	CLAMP, 1" CUSHION LOOP w/ 7/16 MOUNT HOLE	1	40	000-052-155	TEE, 3/16" PLASTIC VACUUM INSERT	2
16	000-047-042	ENGINE, KUBOTA 32.5 HP	1	41	000-169-156	VALVE, CHECK - DIVERTER CONTROL	2
17	000-068-924	HOSE, 1" I.D. SILICONE FLEXIBLE	1	42	000-174-193	WASHER, M10 LOCK S/S	8
18	000-068-1055	HOSE, 5/16" I.D. FUEL X 5" LG.	1	43	000-174-003	WASHER, 1/4" FLAT S/S	1
19	000-068-016	HOSE, 5/16" I.D. RUBBER - BULK	0.66'	44	000-174-005	WASHER, 3/8" FLAT Z/P	4
20	000-068-030	HOSE, 5/32" ID VACUUM - BULK	4'	45	000-174-054	WASHER, 3/8" INT/EXT STAR Z/P	1
21	000-068-221	HOSE, OIL DRAIN	1	46	000-174-021	WASHER, 3/8" LOCK	4
22	000-052-293	INSERT, #23 (1/8" NPT x 3/16" BARB)	1	47	000-174-004	WASHER, 5/16" FLAT, USS	2
23	000-052-097	INSERT, #24 (1/8" NPT X 1/4" BARB)	1	48	000-174-018	WASHER, 5/16" LOCK	2
24	000-052-108	INSERT, #F25 (1/8" FPT x 5/16" BARB)	2	49	000-174-166	WASHER, 5/16" TAB	4
25	000-077-010	KEY, 1/4" x 1-1/2" LG. CLASS 2 FIT	2				

Figure 9-11. Exhaust Assembly
610-013-741 Rev. C

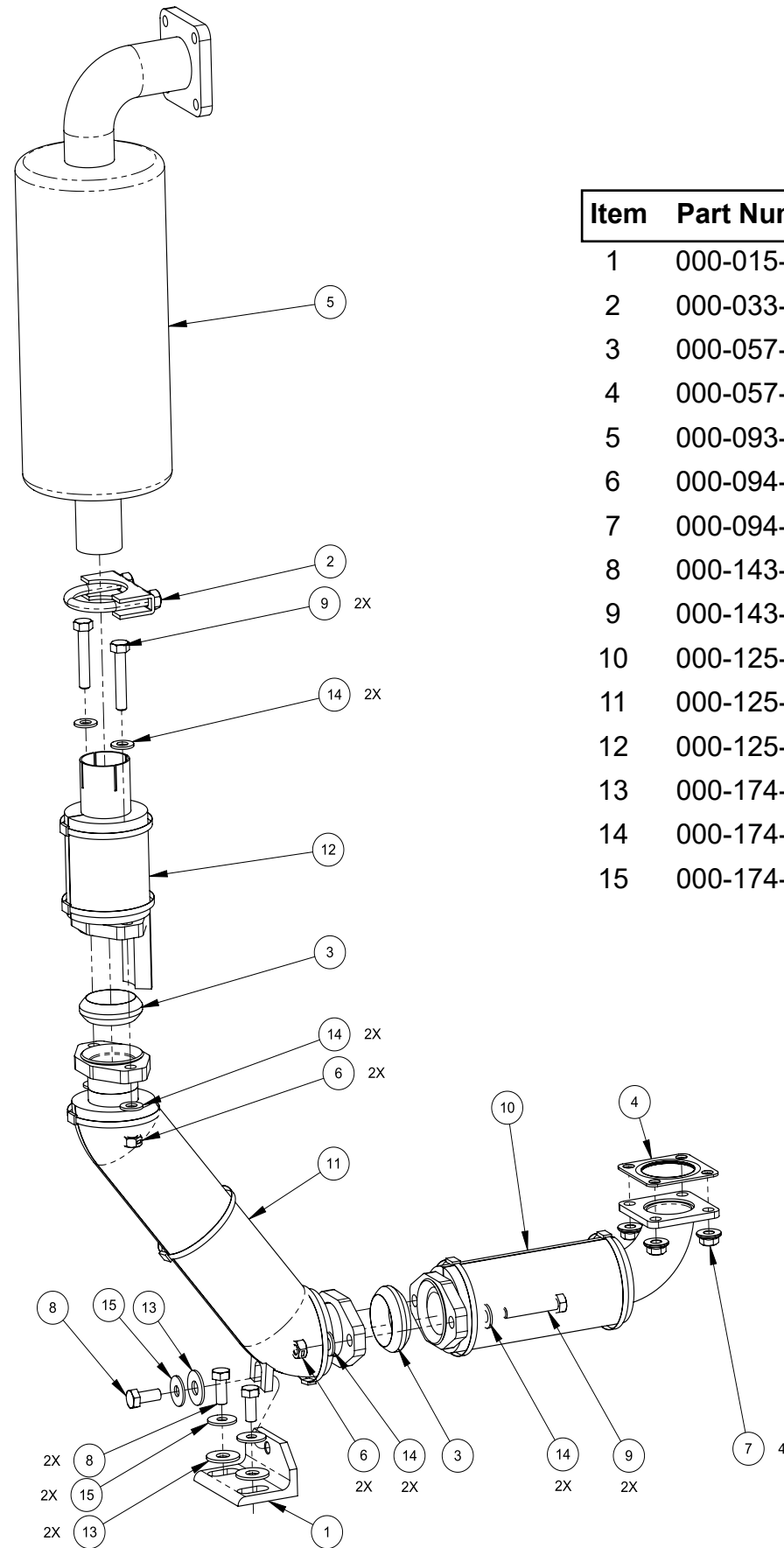
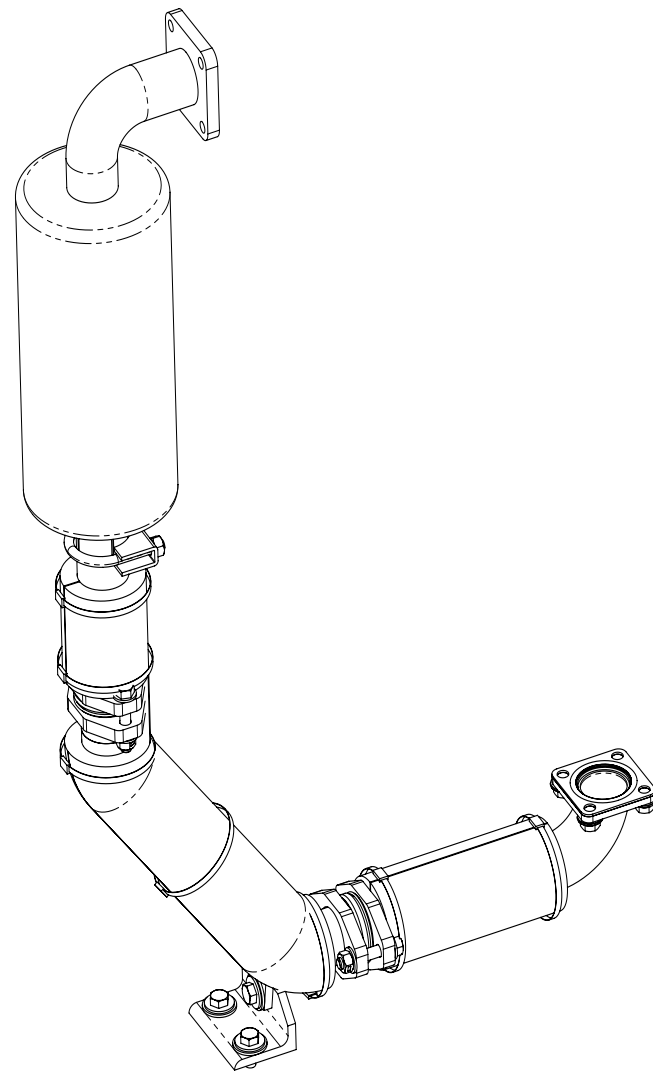

Exhaust Assembly Parts List

Item	Part Number	Description	Qty
1	000-015-393	Bracket, Muffler Support Foot - Coated	1
2	000-033-068	Clamp, 1-1/2" Exhaust	1
3	000-057-199	Gasket, Exhaust Donut	2
4	000-057-146	Gasket, Four Hole Exhaust	1
5	000-093-158	Muffler/Catalytic	1
6	000-094-081	Nut, 5/16"-18UNC Hex 2 Way Locking	4
7	000-094-078	Nut, 5/16-18UNC Hex Flange	4
8	000-143-012	Screw, 5/16"-18UNC X 3/4" Lg.	3
9	000-143-124	Screw, 5/16"-18UNC X 1.75" Lg. Hex Head	4
10	000-125-859	Tube, Lower Exhaust w/ Wrap	1
11	000-125-860	Tube, Mid Exhaust w/ Wrap	1
12	000-125-858	Tube, Upper Exhaust w/ Wrap	1
13	000-174-005	Washer, 3/8" Flat	3
14	000-174-049	Washer, 5/16" Flat	8
15	000-174-004	Washer, 5/16" Flat, USS	3

TITAN 575

Figure 9-12. Top Cover Assembly
610-022-753 Rev. B

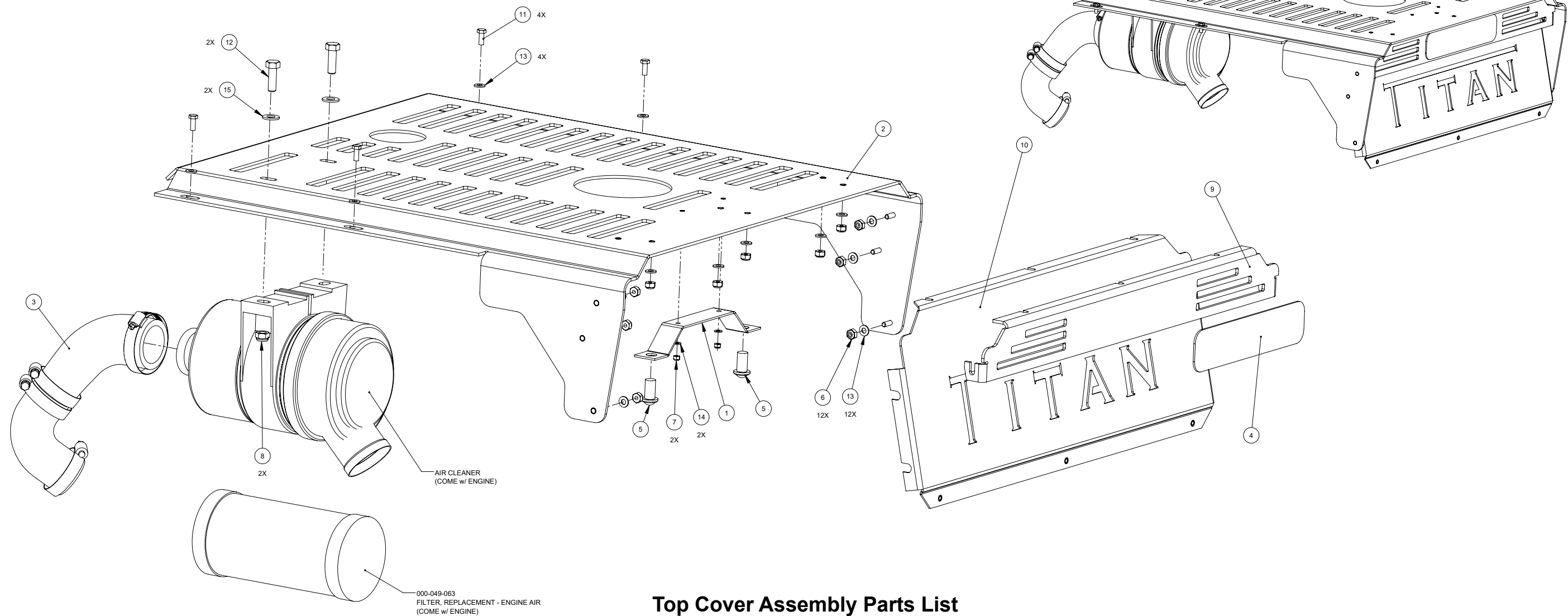

Top Cover Assembly Parts List

Item	Part Number	Description	Qty
1	000-015-1428	BRACKET, LED MOUNTING - COATED	1
2	000-041-919	COVER, MACHINE TOP - COATED 575	1
3	000-068-916	HOSE, KUBOTA AIR INTAKE - MODIFIED (PROD)	1
4	000-081-526	LABEL, DOME - HYDRAMASTER	1
5	000-084-025	LAMP, 12V LED 12MM PANEL MOUNT	2
6	000-094-034	NUT, #10-24UNC HEX NYLOCK	12
7	000-094-063	NUT, #6-32UNC HEX NYLOCK	2
8	000-094-038	NUT, 5/16"-18UNC HEX NYLOCK	2

Item	Part Number	Description	Qty
9	000-100-381	PANEL, BROW END - COATED	1
10	000-100-382	PANEL, BROW FRONT	1
11	000-143-126	SCREW, #10-24UNC x 0.50" LG. HEX HEAD	4
12	000-143-143	SCREW, 5/16"-18UNC X 1.00" LG. HEX HEAD	2
13	000-174-001	WASHER, #10 FLAT	16
14	000-174-045	WASHER, #6 S/S FLAT	2
15	000-174-049	WASHER, 5/16" FLAT	2

Figure 9-13. Flywheel Plate Assembly
610-021-007 Rev. E

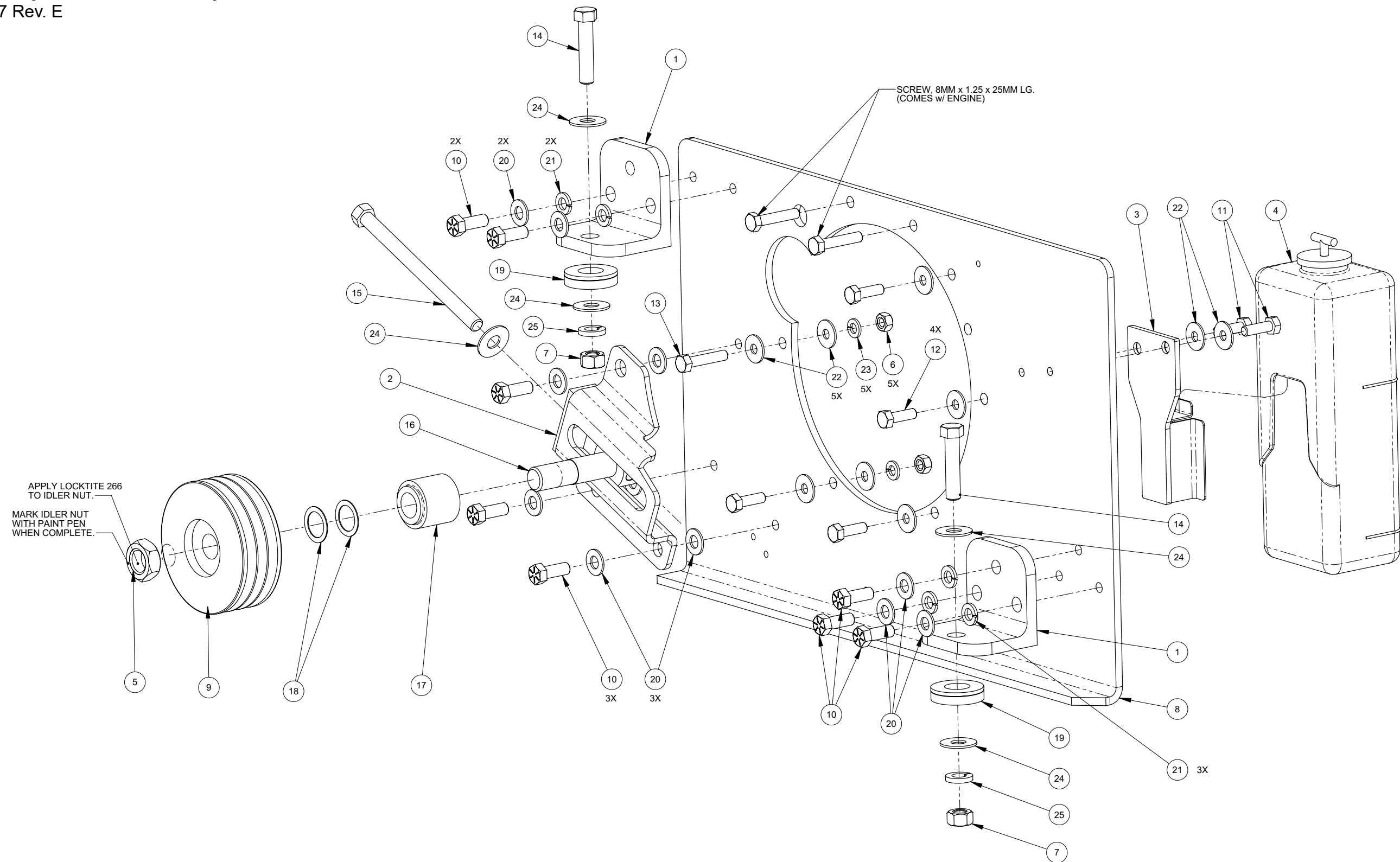

TITAN 575

Flywheel Plate Assembly Parts List

Item	Part Number	Description	Qty
1	000-015-1164	Bracket, Angle - Rear Engine Mount - Coated	2
2	000-015-941	Bracket, I.D.ler Pulley Tensioner - Coated	1
3	---	Bracket, Overflow Jug Mounting (Comes w/ Engine)	1
4	---	Jug, Overflow (Comes w/ Engine)	1
5	000-094-106	Nut, 3/4"-16UNF Hex Jam - Zink Plated	1
6	000-094-120	Nut, 5/16"-18UNC Hex Z/P	5
7	000-094-018	Nut, 7/16"-14UNC Hex Z/P	2
8	000-105-586	Plate, Flywheel, Kubota - Coated	1
9	000-109-141	Pulley, Tri Groove 3VX	1
10	000-143-018	Screw, 3/8"-16UNC X 1" Lg. Hex Head - Grade 8	8
11	000-143-143	Screw, 5/16"-18UNC X 1.00" Lg. Hex Head	2
12	000-143-013	Screw, 5/16"-18UNC X 1.00" Lg. Hex Head Grade 8	4
13	000-143-015	Screw, 5/16-18 X 1 1/2" HHC	1

Item	Part Number	Description	Qty
14	000-143-587	Screw, 7/16"-14UNC X 2" Lg. Hex Head	2
15	000-143-554	Screw, 7/16-14 UNC. X 6.5" Lg. Ft Gr. 5	1
16	000-150-011	Shaft, I.D.ler Pulley	1
17	000-154-195	Spacer, I.D.ler Pulley - 1.403" Lg.	1
18	000-174-177	Washer, 0.813 I.D. X 1.125 O.D. X 0.030 Thk.	2
19	000-174-105	Washer, 1-1/16" I.D. Self Aligning Spherical 2 pc Set	2
20	000-174-005	Washer, 3/8" Flat	11
21	000-174-021	Washer, 3/8" Lock	5
22	000-174-004	Washer, 5/16" Flat	12
23	000-174-018	Washer, 5/16" Lock	5
24	000-174-006	Washer, 7/16" Flat	5
25	000-174-022	Washer, 7/16" Lock	2

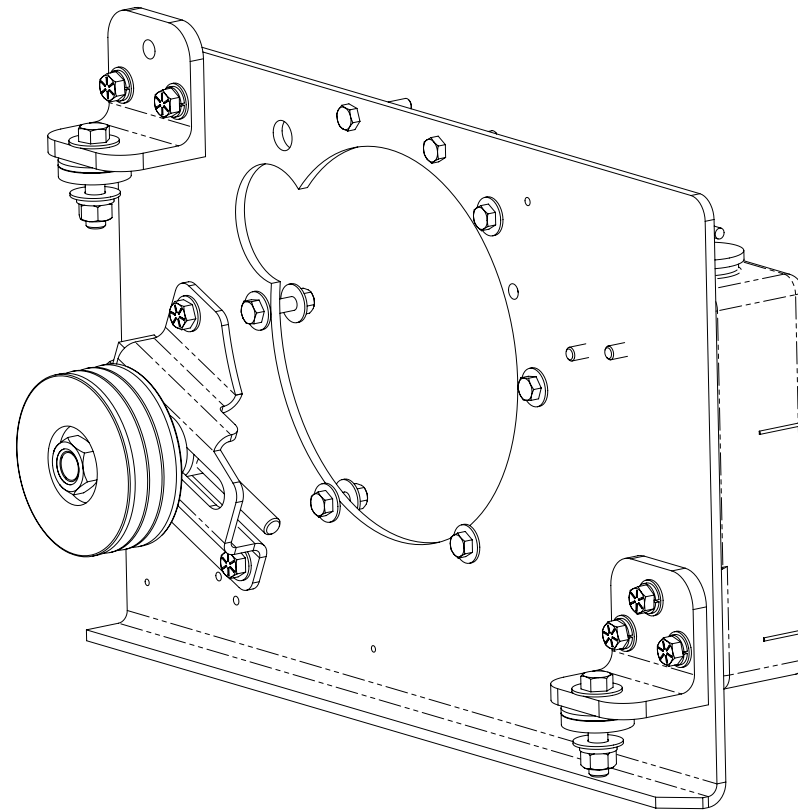
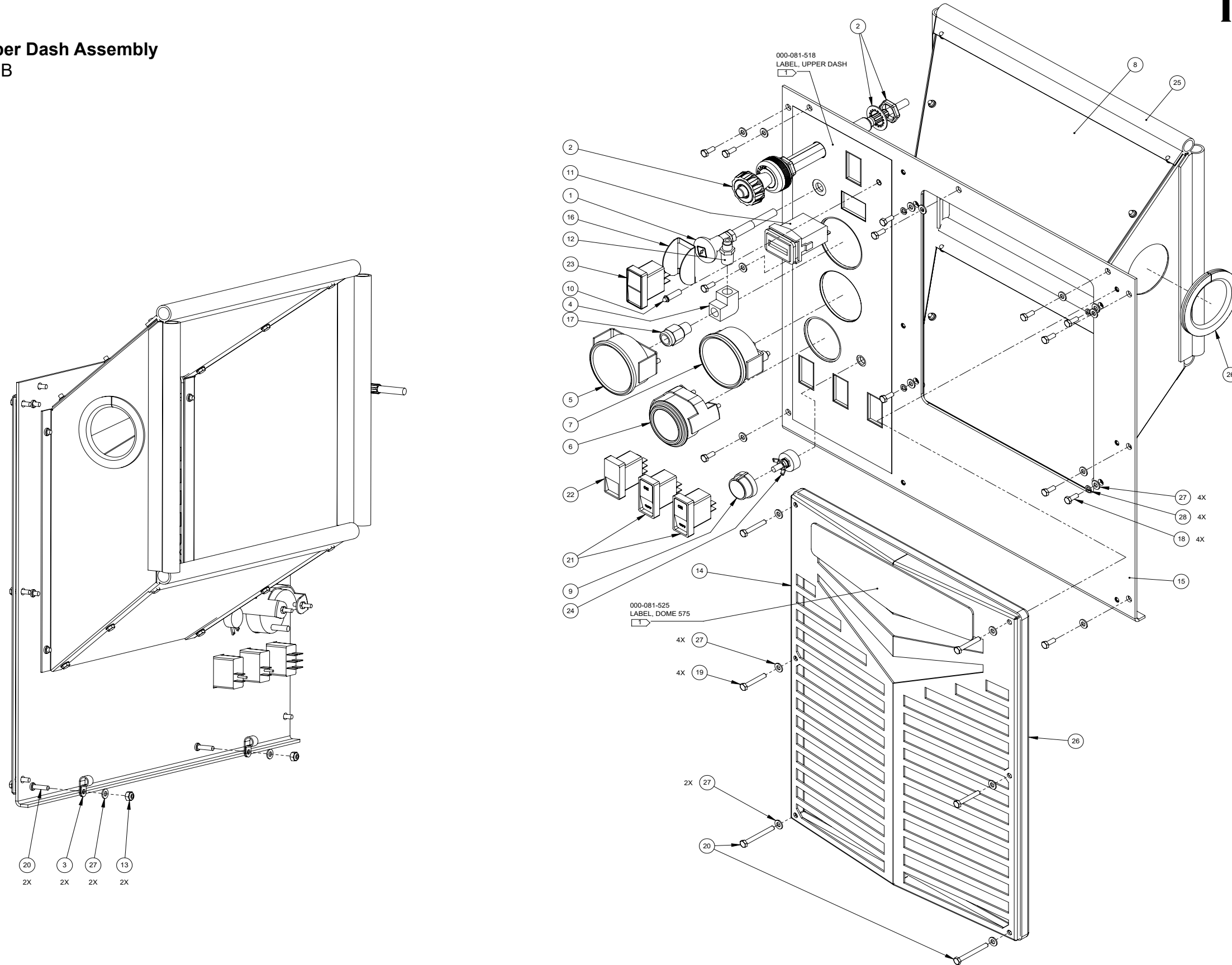

Figure 9-14. Upper Dash Assembly
610-020-753 Rev. B



TITAN 575

Upper Dash Assembly Parts List

Item	Part Number	Description	Qty
1	000-025-003	CABLE, CHOKE WITH DETENT	1
2	000-025-033	CABLE, THROTTLE - MODIFIED 575	1
3	000-033-128	CLAMP, 3/8" NYLON HOSE	2
4	000-052-088	ELBOW, 1/4" FPT x FPT	1
5	000-074-007	GAUGE, PRESSURE 0 -1500 PSI, UPC #401406.	1
6	000-074-016	GAUGE, TEMPERATURE (140-320°F)	1
7	000-074-017	GAUGE, 0-30" HG VAC. 2 1/2" HYDRAMASTER FACE	1
8	000-042-076	HOUSING, RADIATOR SHROUD	1
9	000-061-056	KNOB, TEMPERATURE ADJUSTMENT	1
10	000-084-010	LIGHT, GREEN LED INDICATOR MINI	1
11	000-074-170	METER, RECTANGULAR HOUR w/o BEZEL	1
12	000-052-527	NIPPLE, 1/4" SAE x 1/4" NPT	1
13	000-094-034	NUT, #10-24UNC HEX NYLOCK	2
14	000-100-386	PANEL, GRILL - TITAN 575	1

Item	Part Number	Description	Qty
15	000-100-385	PANEL, UPPER DASH - COATED E01	1
16	000-108-188	PROTECTOR, ROCKER SWITCH - COATED	1
17	000-135-052	REGULATOR, HI PSI SNUBBER	1
18	000-143-126	SCREW, #10-24UNC x 0.50" LG. HEX HEAD	13
19	000-143-171	SCREW, #10-24UNC x 1.25" LG. HEX HEAD	4
20	000-143-065	SCREW, #10-24UNC x 1.75" LG. HEX HEAD	2
21	000-157-040	SWITCH, 20 AMP ROCKER	2
22	000-157-131	SWITCH, 3 WAY ROCKER	1
23	000-157-152	SWITCH, IGNITION	1
24	000-149-560	THERMOSTAT, POTENTIOMETER	1
25	000-131-060	TRIMLOK, 3/4" BULB x 3/16" OPENING	4.67'
26	000-131-131	TRIMLOK, 3/8 X 1/8 RUBBER	0.67'
27	000-174-001	WASHER, #10 FLAT	21
28	000-174-014	WASHER, #10 LOCK	4



NOTICE

* To order a spare thermostat (P/N 000-149-560), specify P/N 000-149-561.

Figure 9-15. Electrical Panel Assembly - View 1 of 2
610-011-741 Rev. I

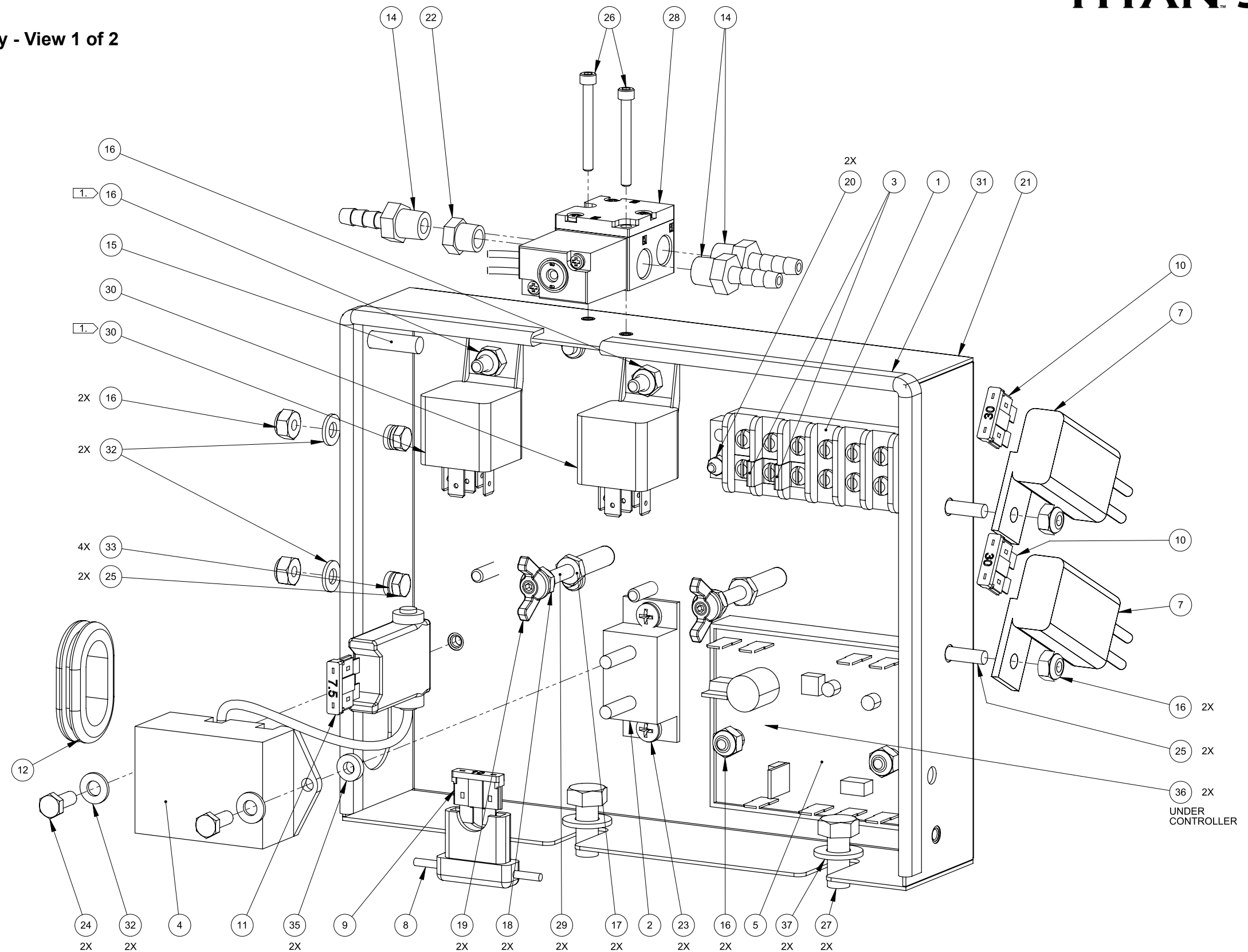

TITAN 575

Figure 9-16. Electrical Panel Assembly - View 2 of 2
610-011-741 Rev. I

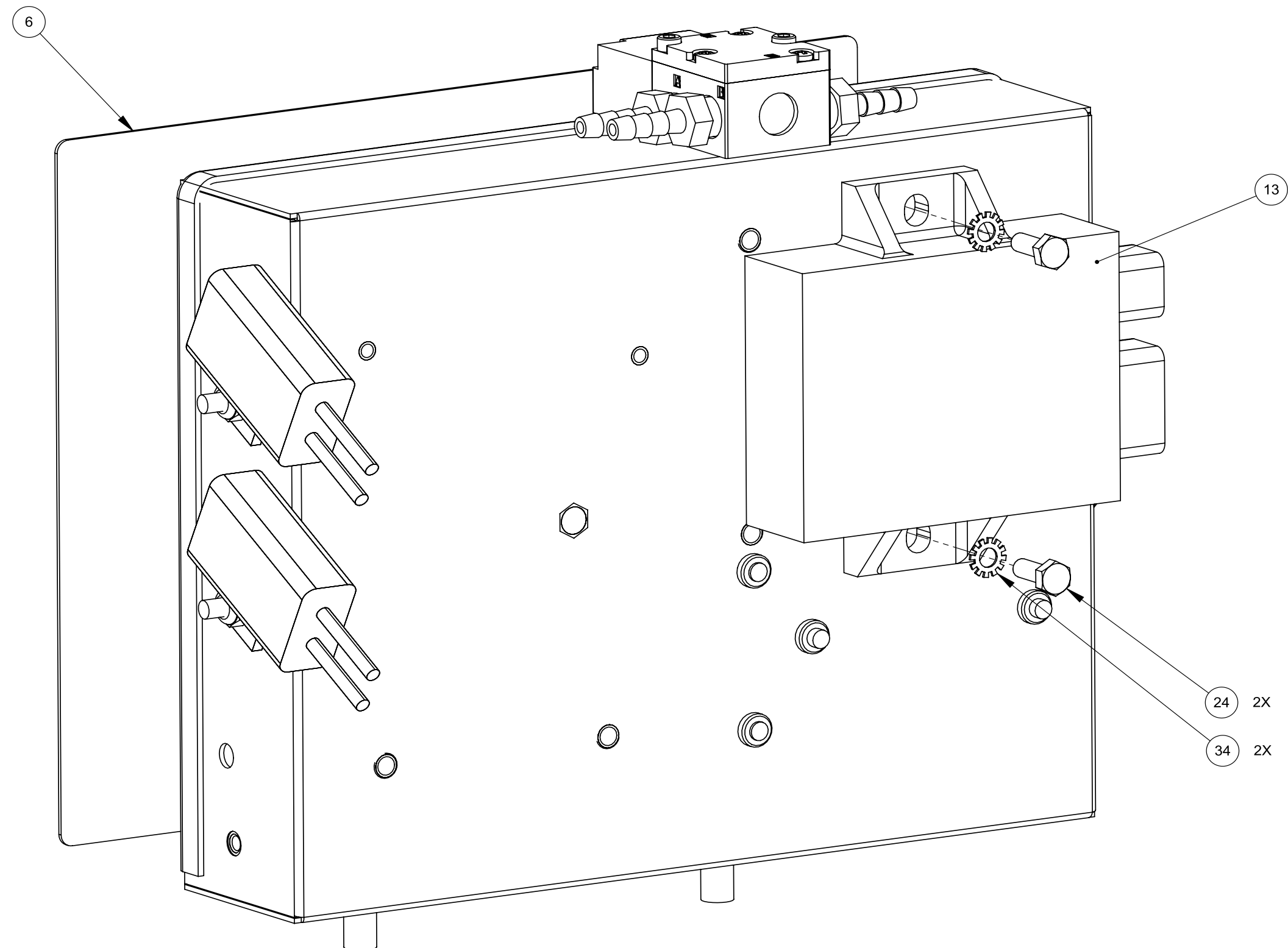

Electrical Panel Assembly Parts List

Item	Part Number	Description	Qty
1	000-012-002	Block, 6 Post Terminal	1
2	000-018-040	Circuit Breaker, 50 Amp	1
3	000-037-011	Connector, Jumper Terminal Block	2
4	000-074-173	Controller, Fuel Pump	1
5	000-074-125	Controller, Temp Single Analog Input - RTD	1
6	000-041-478	Cover, Electrical Panel - Coated	1
7	000-056-006	Fuse Holder, In-Line - Weatherproof	2
8	000-056-031	Fuse Holder, Inline 20 Amp	1
9	000-056-002	Fuse, 10 Amp	1
10	000-056-011	Fuse, 30 Amp	2
11	000-056-012	Fuse, 7.5 Amp	1
12	000-060-014	Grommet, 1.00" I.D. X 1.50" O.D.	1
13	000-072-018	Ignition Processor, Kubota WG972	1
14	000-052-293	Insert, #23 (1/8" NPT X 3/16" Barb)	3
15	000-084-010	Light, Green LED Indicator Mini	1
16	000-094-034	Nut, #10-24UNC Nylock *	8
17	000-094-003	Nut, #10-32UNF Hex	2
18	000-094-058	Nut, #10-32UNF Nylock	2
19	000-094-108	Nut, #10-32UNF Wing	2

Item	Part Number	Description	Qty
20	000-094-063	Nut, #6-32UNC Nylock	2
21	000-100-182	Panel, Electrical - Universal - Coated	1
22	000-106-014	Plug, Vent	1
23	000-143-533	Screw, #10-24UNC X 0.25" Lg. Pan Head Phillips	2
24	000-143-126	Screw, #10-24UNC X 0.50" Lg. Hex Head	4
25	000-143-132	Screw, #10-24UNC X 0.75" Lg. Hex Head	4
26	000-143-700	Screw, #6-32UNC X 1.25" Lg. Socket Head	2
27	000-143-012	Screw, 5/16"-18UNC X 3/4" Lg.	2
28	000-169-226	Solenoid, Air Actuator 4-Way Valve	1
29	000-156-040	Stud, #10-32 X 2.25" Lg.	2
30	000-157-022	Switch, Relay *	2
31	000-131-131	Trimlok, 3/8" X 1/8"	1
32	000-174-001	Washer, #10 Flat	4
33	000-174-014	Washer, #10 Lock	4
34	000-174-015	Washer, #10 Outside Star	2
35	000-174-192	Washer, #10 Rubber	2
36	000-174-191	Washer, #10 X 7/16" Fiber	2
37	000-174-049	Washer, 5/16" Flat	2

NOTICE

* Items 16 and 30 used with the High Pressure Washing Kit option, P/N 000-079-126.

TITAN 575

Figure 9-17. Blower Assembly
610-002-741 Rev. I

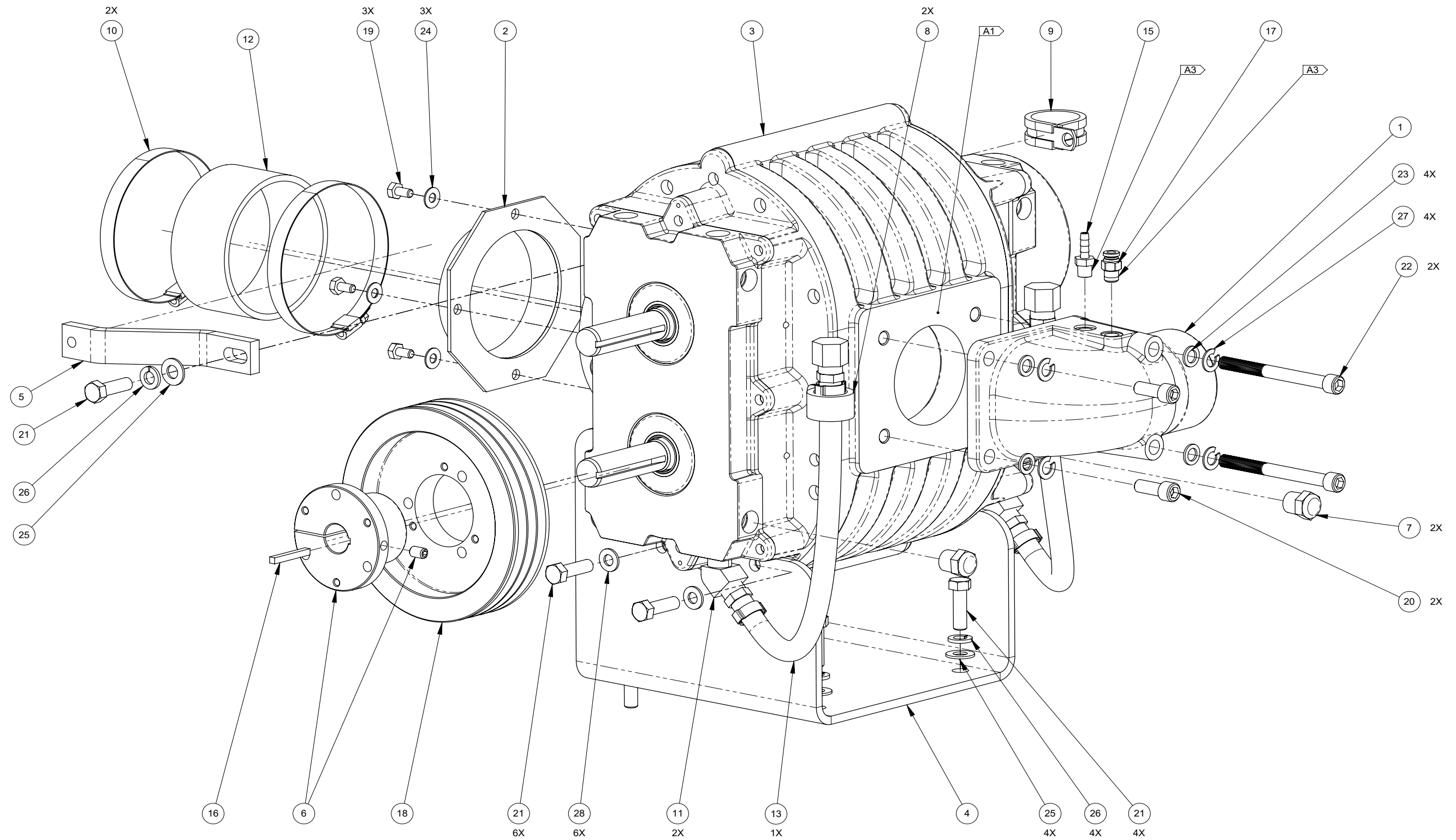

Blower Assembly Parts List

Item	Part Number	Description	Qty
1	000-001-872	ADAPTER, BLOWER INLET 4007 - CASTING	1
2	000-001-183	ADAPTER, BLOWER OUTLET - COATED	1
3	000-111-147	BLOWER, 4007 DOMINATOR	1
4	000-015-976	BRACKET, BLOWER MOUNTING - COATED	1
5	000-015-988	BRACKET, BLOWER TO SILENCER SUPPORT - CTD	1
6	000-020-071	BUSHING, QD SDS STYLE, 7/8" BORE	1
7	000-027-112	CAP, OIL SIGHT GLASS TUTHILL BLOWER (COMES w/ BLOWER)	2
8	000-033-117	CLAMP, 1" CUSHION LOOP w/ 7/16 MOUNT HOLE	2
9	000-033-116	CLAMP, 1-1/2" CUSHION LOOP w/ 7/16" HOLE	1
10	000-033-015	CLAMP, 4" HOSE	2
11	000-052-083	ELBOW, 3/8" NPT STREET x 45°	2
12	000-068-944	HOSE, 4" I.D. x 3 PLY SILICONE X 2.0" LG	1
13	000-068-219	HOSE, SPITFIRE PUMP DRAIN	1

Item	Part Number	Description	Qty
14	000-068-219	HOSE, SPITFIRE PUMP DRAIN	1
15	000-052-293	INSERT, #23 (1/8" NPT x 3/16" BARB)	1
16	000-077-011	KEY, 3/16" X 1-1/2" LG.	1
17	000-052-814	NIPPLE, 1/8" NPT x 1/4" PRESSTO LOCK	1
18	000-109-124	PULLEY, Ø6.5" O.D. TRI-3VX SECTION	1
19	000-143-333	SCREW, 1/4"-20UNC x 0.50" LG. S/S HEX HEAD	3
20	000-143-081	SCREW, 3/8"-16UNC x 1" LG. SOCKET HEAD	2
21	000-143-025	SCREW, 3/8"-16UNC x 1.25" LG. HEX HEAD GR. 8	11
22	000-143-786	SCREW, 3/8-16 X 4" SOCKET CAP	2
23	000-174-055	WASHER, 0.390" I.D. x 0.625 O.D. x 0.06 THK. FLAT	4
24	000-174-003	WASHER, 1/4" FLAT S/S	3
25	000-174-005	WASHER, 3/8" FLAT Z/P	5
26	000-174-021	WASHER, 3/8" LOCK	5
27	000-174-057	WASHER, 3/8" LOCK	4
28	000-174-049	WASHER, 5/16" FLAT	6

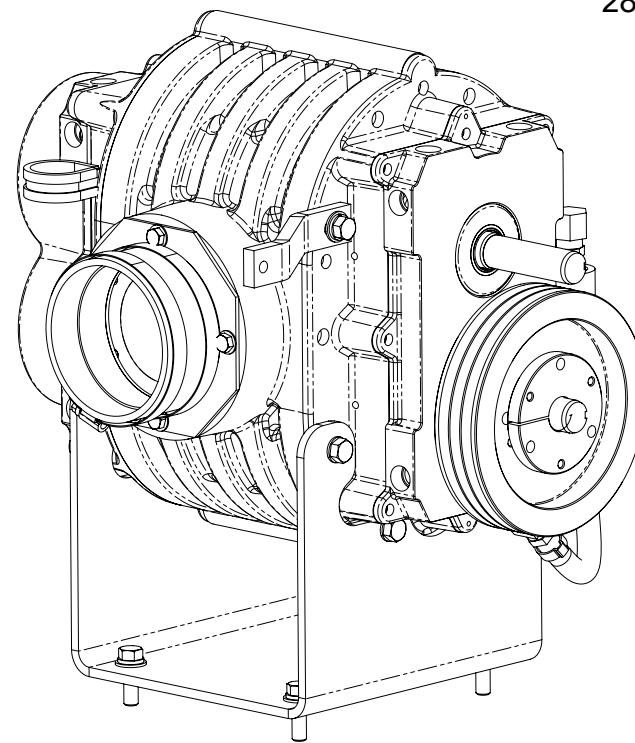

TITAN 575

Figure 9-18. Pump and Silencer Assembly
610-021-741 Rev. B

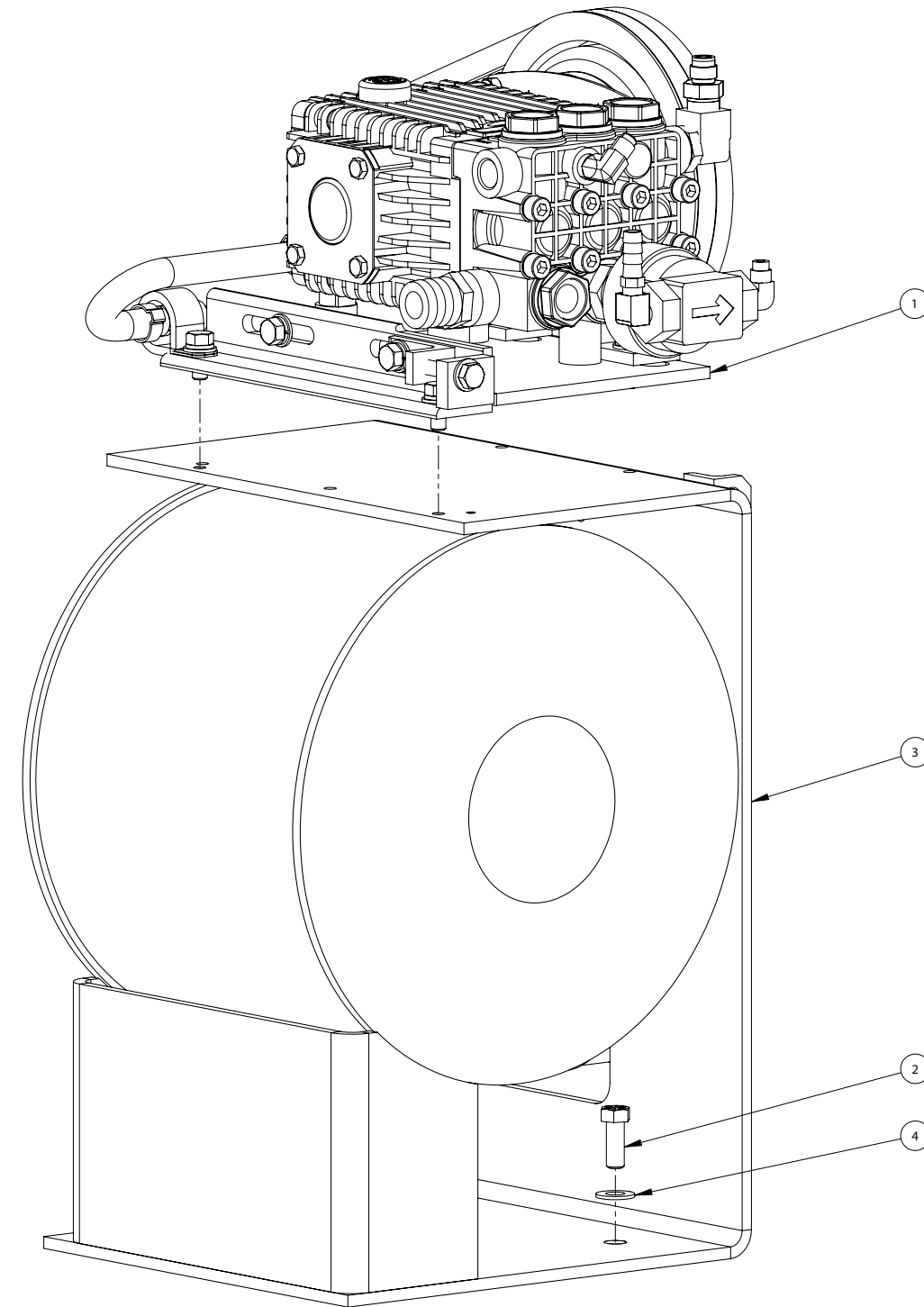
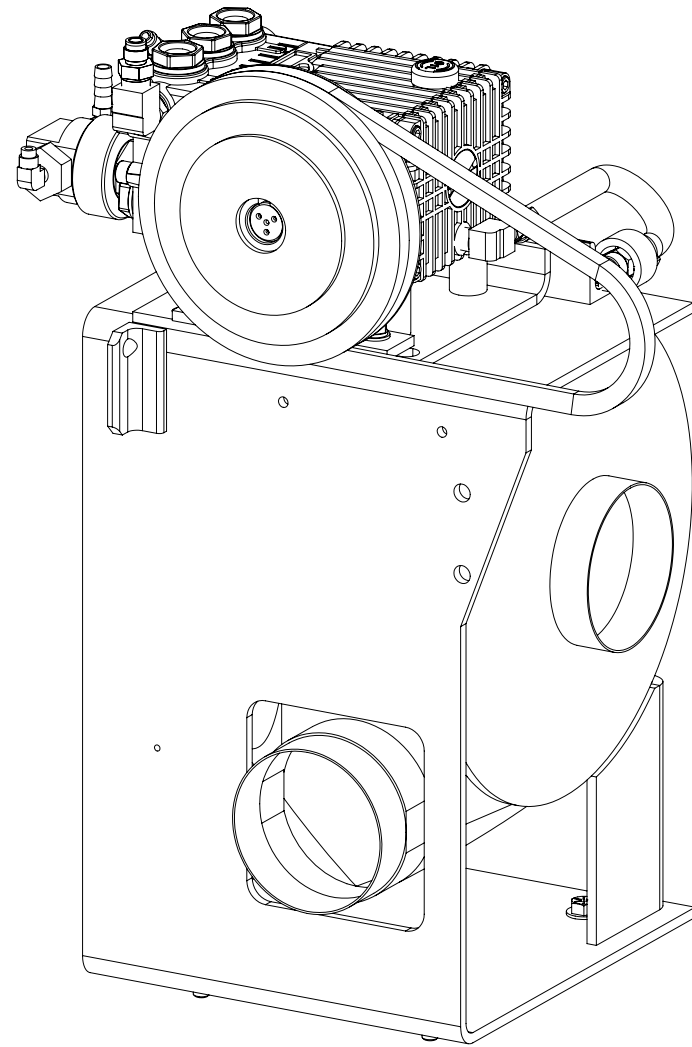

Pump and Silencer Assembly Parts List

Item	Part Number	Description	Qty
1	610-007-741	Assembly, Pump	1
2	000-143-018	Screw, 3/8"-16UNC X 1" Hex Head - Grade 8	4

Item	Part Number	Description	Qty
3	000-093-105	Silencer, 4" Slip Connection - Coated	1
4	000-174-005	Washer, 3/8" Flat	4

Figure 9-19. Pump Assembly - View 1 of 2
610-007-741 Rev. C

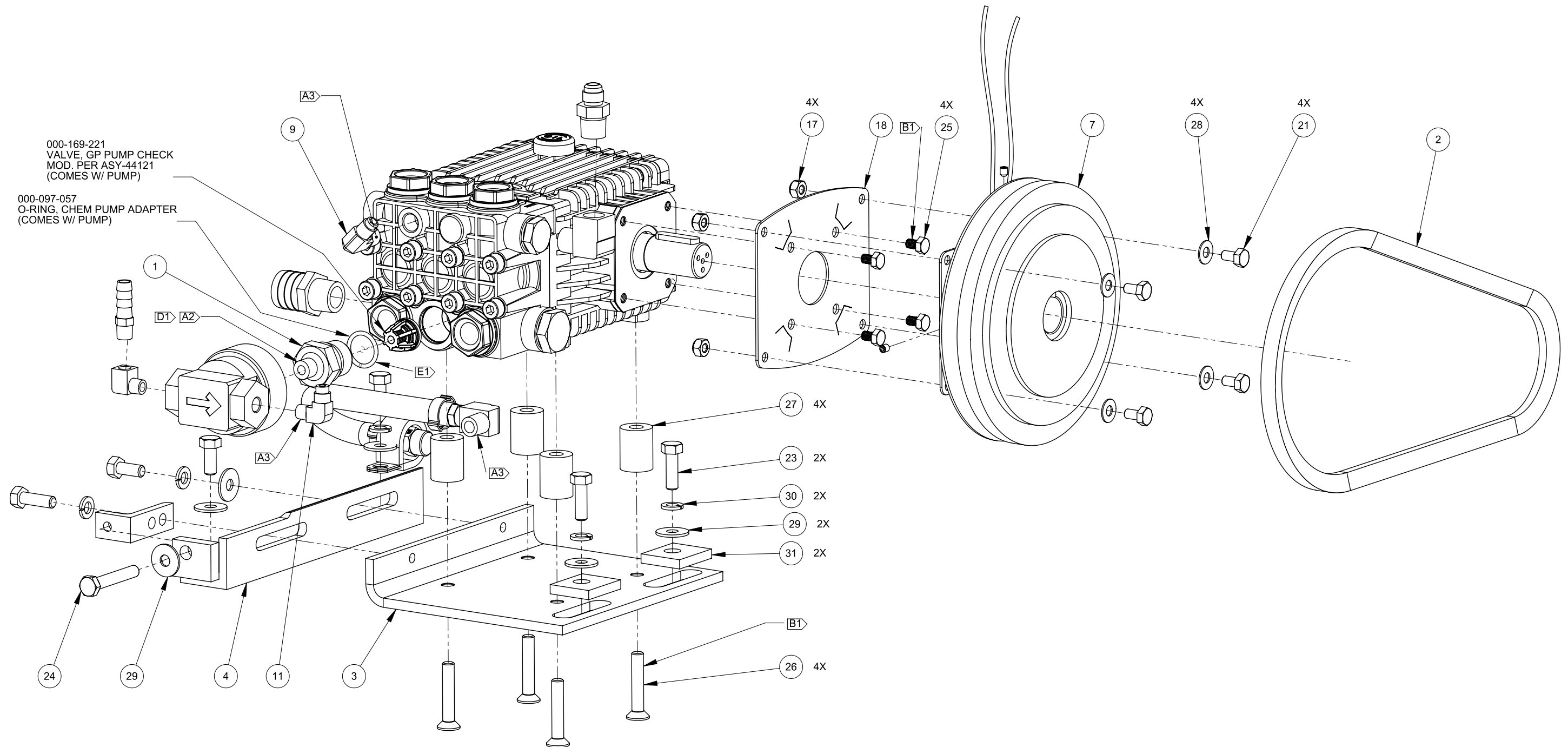

TITAN 575

Figure 9-20. Pump Assembly - View 2 of 2
610-007-741 Rev. C

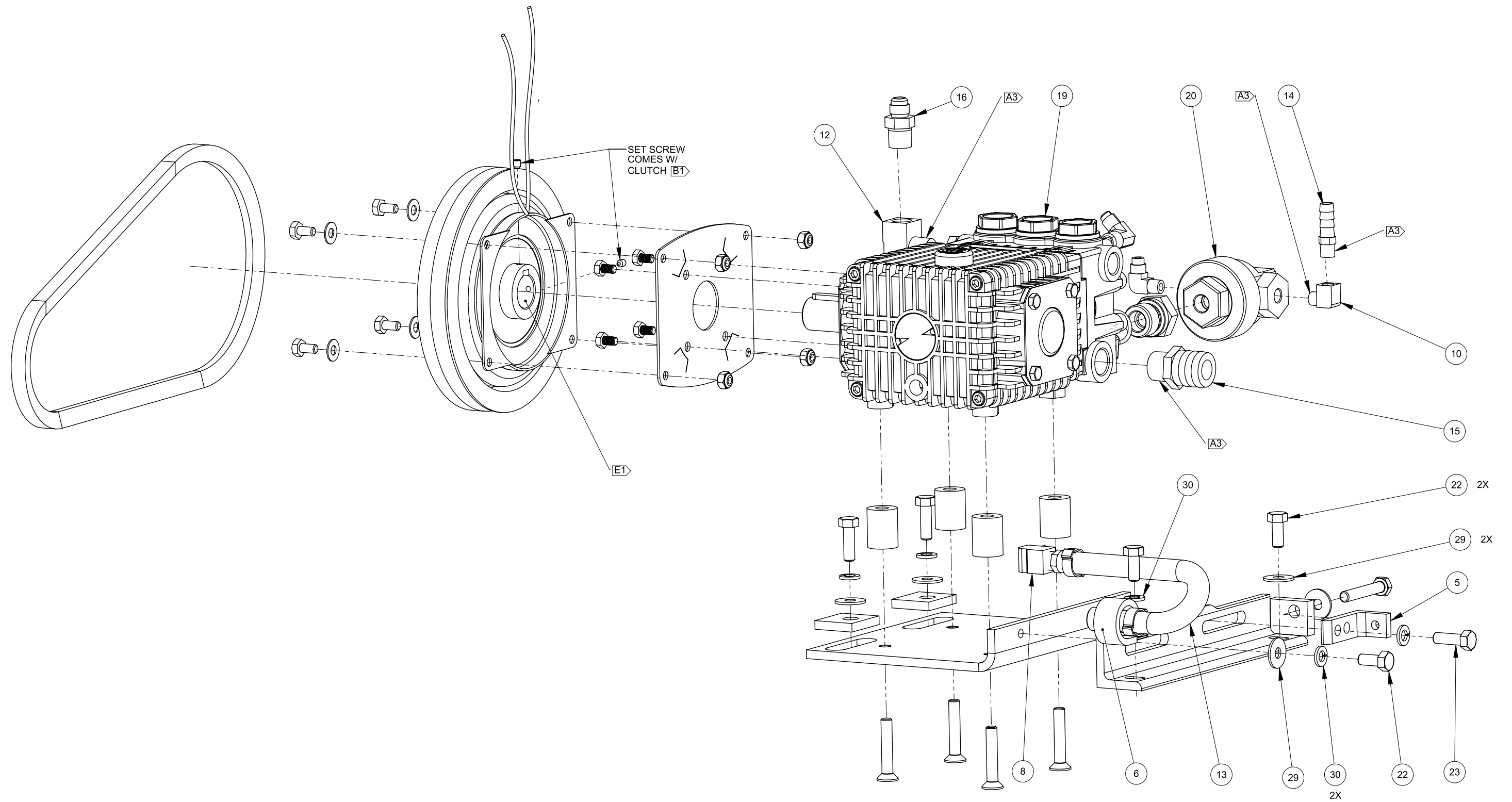

Pump Assembly Parts List

Item	Part Number	Description	Qty
1	000-001-154	Adapter, GP To Chem Pump S/S 4.0 Gallon	1
2	000-010-128	Belt, HD9330 Green Back	1
3	000-015-990	Bracket, Pump Mount - Coated	1
4	000-015-991	Bracket, Pump Mount Guide - Coated	1
5	000-015-998	Bracket, Pump Tensioning - Coated	1
6	000-033-117	Clamp, 1" Cushion Loop w/ 7/16 Mount Hole	1
7	000-036-008	Clutch, 7" O.D. 24mm Single Groove	1
8	000-052-085	Elbow, 1/4" NPT Street	1
9	000-052-532	Elbow, 1/4" SAE X 1/4" NPT	1
10	000-052-084	Elbow, 1/8" NPT Street	1
11	000-052-531	Elbow, 1/8" NPT X 1/4" SAE	1
12	000-052-086	Elbow, 3/8" NPT Street	1
13	000-068-794	Hose, 3/8" X 17" Lg. Pump Drain	1
14	000-052-099	Insert, #26 (1/8" NPT X 3/8" Barb)	1
15	000-052-753	Insert, #816 (1/2" NPT X 1" Barb)	1
16	000-052-528	Nipple, 3/8" M JIC X 3/8" NPT	1

Item	Part Number	Description	Qty
17	000-094-071	Nut, 1/4"-20UNC Nylock Half	4
18	000-105-550	Plate, Pump Clutch - GP 4.0 gpm	1
19	000-111-188	Pump, 4.0 gpm GP	1
20	000-111-184	Pump, GP Chemical	1
21	000-143-333	Screw, 1/4"-20UNC X 0.50" Lg. Hex Head	4
22	000-143-156	Screw, 5/16"-18UNC X 0.75" Lg. Hex Head Grd 8	3
23	000-143-013	Screw, 5/16"-18UNC X 1.00" Lg. Hex Head Grade 8	3
24	000-143-585	Screw, 5/16"-18UNC X 2" Lg. Hex Head Grade 5	1
25	000-143-608	Screw, 6mm X 10mm Lg. Z/P	4
26	000-143-084	Screw, 8mm X 1.25 X 45mm Lg. Flat Head Hex Drive	4
27	000-154-184	Spacer, 3/8" I.D. X 1.125" Lg. X 7/8" O.D. - Coated	4
28	000-174-003	Washer, 1/4" Flat	4
29	000-174-004	Washer, 5/16" Flat, USS	6
30	000-174-018	Washer, 5/16" Lock	5
31	000-174-068	Washer, Blower Feet - Coated	2

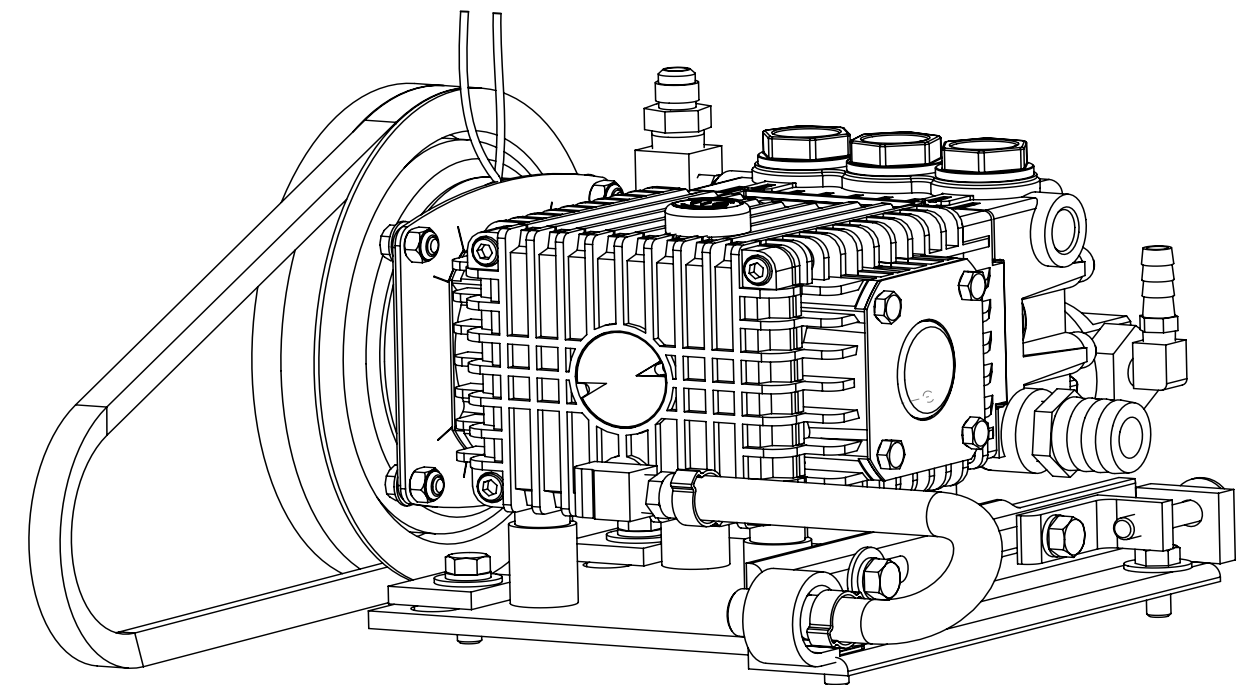
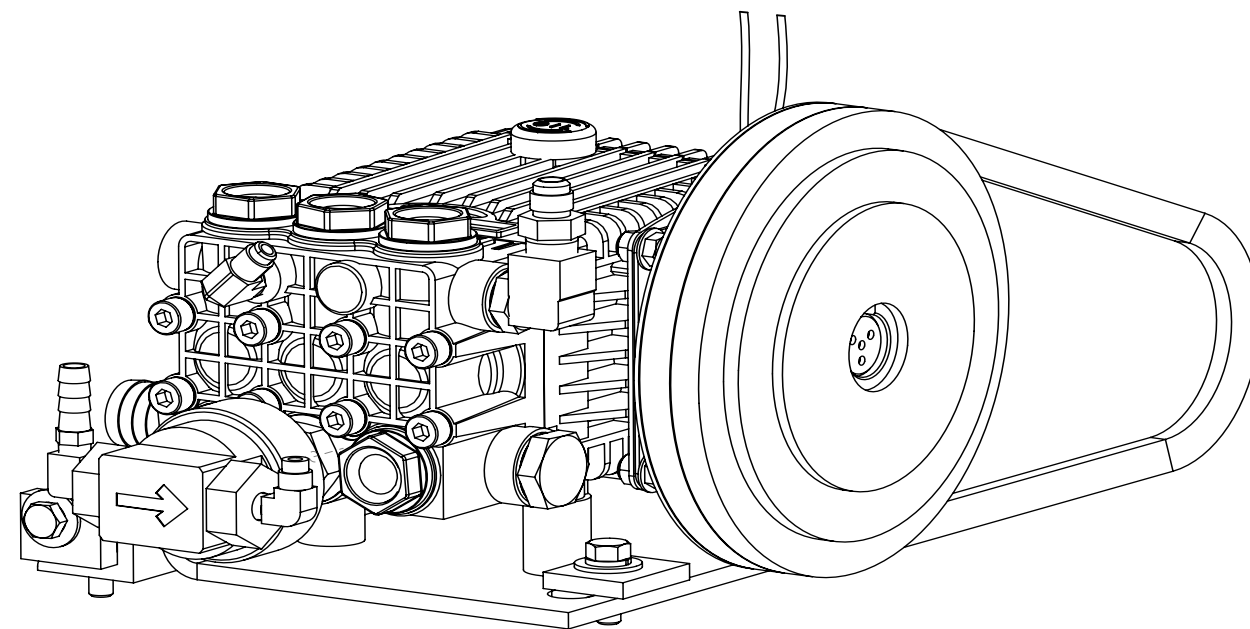

TITAN 575

Figure 9-21. Water Box Assembly
610-010-741 Rev. D

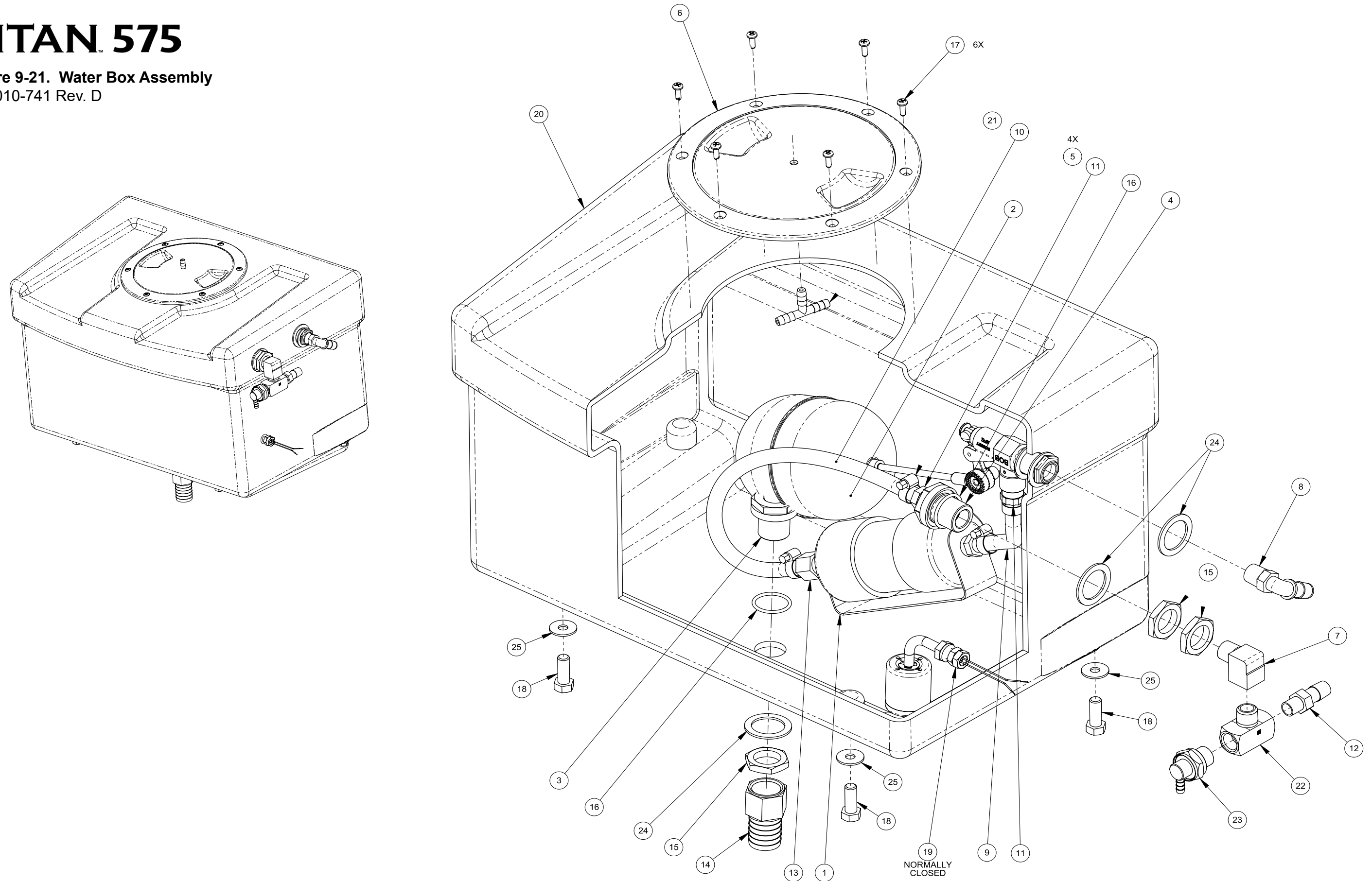

Water Box Assembly Parts List

Item	Part Number	Description	Qty
1	000-049-151	Assembly, Diffuser Filter	1
2	000-169-235	Assembly, Float Valve	1
3	000-052-728	Bulkhead, 1/2" FPT	1
4	000-052-660	Bulkhead, 3/8" FPT X 3/8" FPT	1
5	000-033-003	Clamp, Size #4 Mini Hose	4
6	000-041-005	Cover, 6" Access	1
7	000-052-086	Elbow, 3/8" NPT Street	1
8	000-052-355	Elbow, 3/8" NPT X 1/2" Hose, GFBN	1
9	000-068-326	Hose, 3/8" I.D. Clear Braid	1
10	000-068-326	Hose, 3/8" I.D. Clear w/ Braid	1
11	000-052-104	Insert, #66 (3/8" NPT X 3/8" Barb)	2
12	000-052-056	Insert, #68 GFBN	1
13	000-052-488	Insert, #F66 (3/8" NPT X 3/8" Hose Barb)	1

Item	Part Number	Description	Qty
14	000-052-754	Insert, #F816 (1/2" FPT X 1" Barb)	1
15	000-094-097	Nut, 1"-14UNS Brass	3
16	000-097-041	O-Ring, 1/2" Bulk Head	2
17	000-143-314	Screw, #8 X 1/2" Lg. Pan Head	6
18	000-143-096	Screw, 3/8"-16UNC X 1.00" Lg. Hex Head	4
19	000-157-163	Switch, w/Protector, Polypropylene Barrel	1
20	000-159-135	Tank, Poly Water Box 8G	1
21	000-052-156	Tee, 1/4" Plastic	1
22	000-052-447	Tee, 3/8" NPT Male Branch	1
23	000-169-224	Valve, Mechanical 145 Degree	1
24	000-174-063	Washer, 1.5" O.D. X 1.073" I.D. X 0.075" Thk.	3
25	000-174-004	Washer, 5/16" Flat, USS	4

TITAN 575

Figure 9-22. Diffuser Filter Assembly
000-049-151 Rev. B

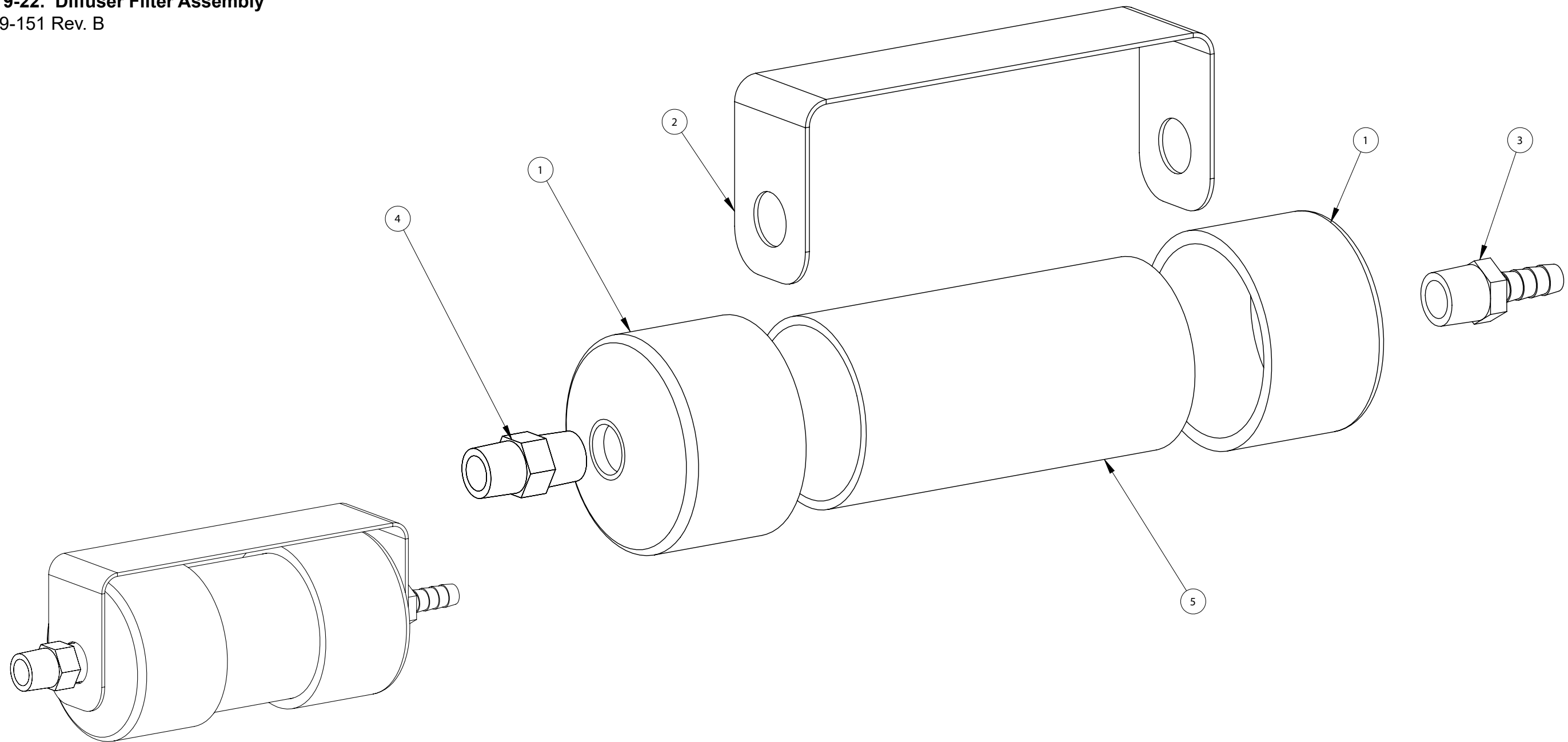

Diffuser Assembly Parts List

Item	Part Number	Description	Qty
1	000-027-115	Cap, 2" PVC Modified for Diffuser	2
2	000-033-131	Clamp, Diffuser	1
3	000-052-104	Insert, #66 (3/8" NPT X 3/8" Barb)	1

Item	Part Number	Description	Qty
4	000-052-074	Nipple, 3/8" NPT Hex	1
5	000-125-222	Tube, Diffuser	1

Figure 9-23. Lower Dash Assembly - View 1 of 2
610-019-753 Rev. A

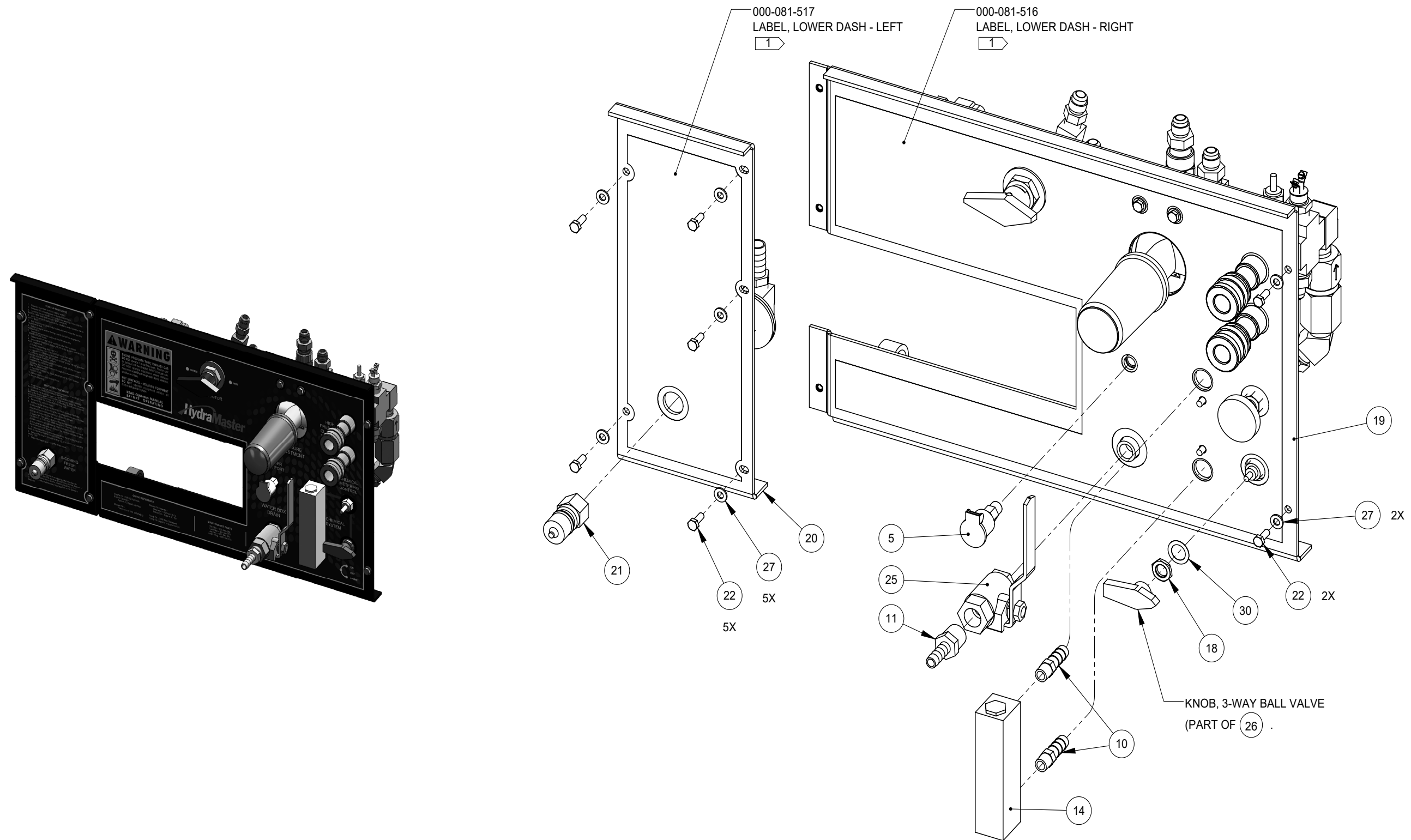

TITAN 575

Figure 9-24. Lower Dash Assembly - View 2 of 2
610-019-753 Rev. A

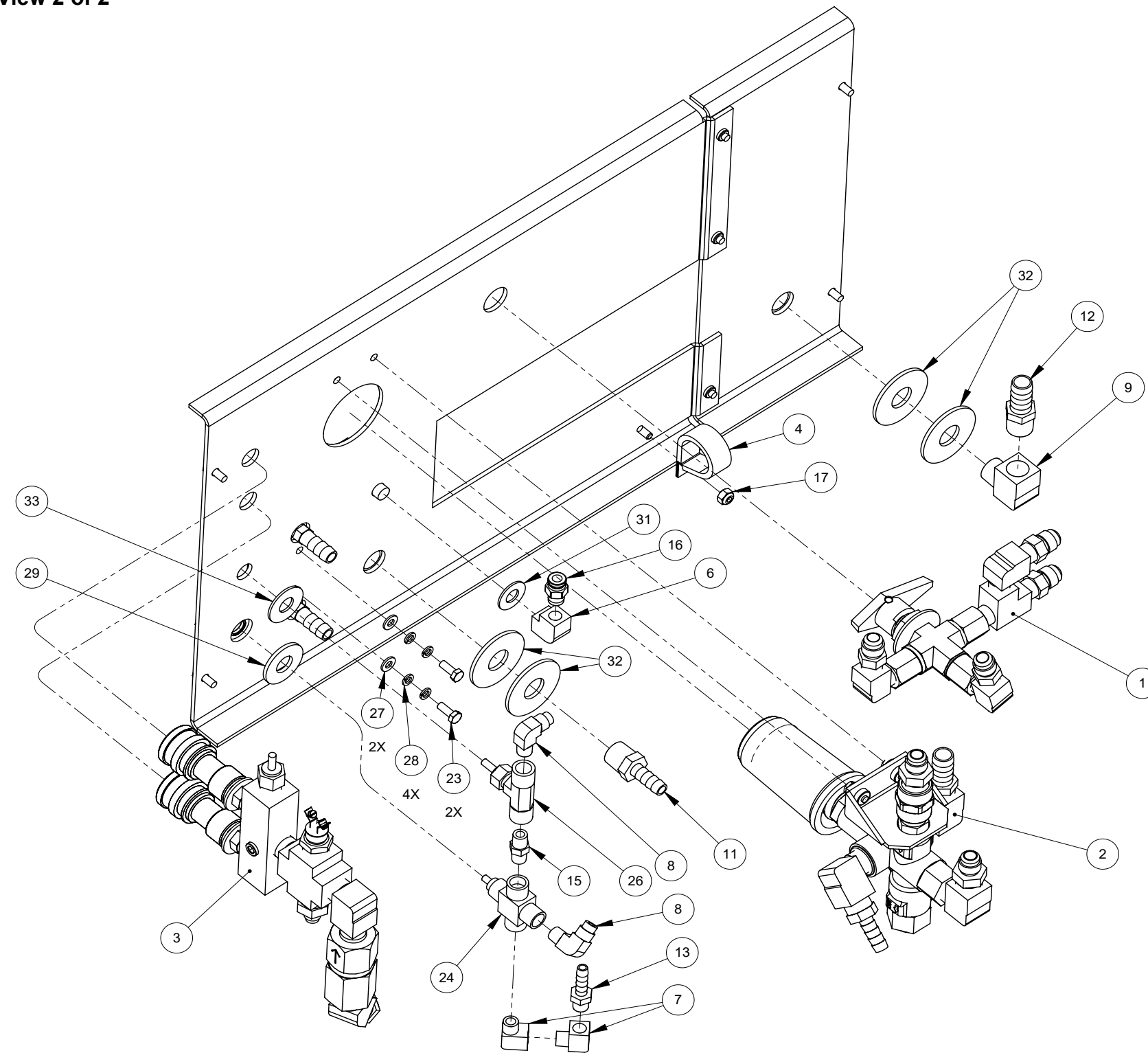

Lower Dash Assembly Parts List

Item	Part Number	Description	Qty
1	610-026-741	Assembly, 3-Way Valve	1
2	610-009-741	Assembly, By-Pass Valve	1
3	610-008-741	Assembly, Hi Pressure Manifold	1
4	000-033-057	Clamp, 1" Cushion Loop	1
5	000-052-272	Cup, Gravity Feed Oil Blower Lube Port	1
6	000-052-089	Elbow, 1/8" NPT Female	1
7	000-052-084	Elbow, 1/8" NPT Street	2
8	000-052-531	Elbow, 1/8" NPT X 1/4" SAE	2
9	000-052-086	Elbow, 3/8" NPT Street	1
10	000-052-099	Insert, #26 (1/8" NPT X 3/8" Barb)	2
11	000-052-104	Insert, #66 (3/8" NPT X 3/8" Barb)	2
12	000-052-105	Insert, #68 (3/8" NPT X 1/2" Barb)	1
13	000-052-097	Insert, #24	1
14	000-074-030	Meter, Chemical Flow Raw	1
15	000-052-069	Nipple, 1/8" NPT Hex	1
16	000-052-814	Nipple, 1/8" NPT X 1/4" Pressto Lock	1
17	000-094-034	Nut, #10-24UNC Nylock	1

Item	Part Number	Description	Qty
18	000-094-098	Nut, 7/16"-24UNF - 2-Way Metering Valve	1
19	000-100-383	Panel, Lower Dash - Right - Coated	1
20	000-100-384	Panel, Lower Dash, Left - Coated	1
21	000-052-052	Quick Connect, 660 3/8" Brass w/ EPDM O-Ring	1
22	000-143-126	Screw, #10-24UNC X 0.50" Lg. Hex Head	7
23	000-143-327	Screw, #10-32UNF X 0.50" Lg. Hex Head	2
24	000-169-0171	Valve, 3-Way Ball O-Ring Style	1
25	000-169-064	Valve, 3/8" NPT Full Port Ball	1
26	000-169-160	Valve, Chemical Metering	1
27	000-174-001	Washer, #10 Flat	9
28	000-174-014	Washer, #10 Lock	4
29	000-174-007	Washer, 1/2" Flat	1
30	000-174-062	Washer, 1/2" I.D. X 3/4" O.D. X 0.010" Thk	1
31	000-174-032	Washer, 3/8" Flat	1
32	000-174-008	Washer, 5/8" Flat	4
33	000-174-038	Washer, 7/16" SAE Flat	1

TITAN 575

Figure 9-25. Side Cover - Console Assembly
610-023-744 Rev. A

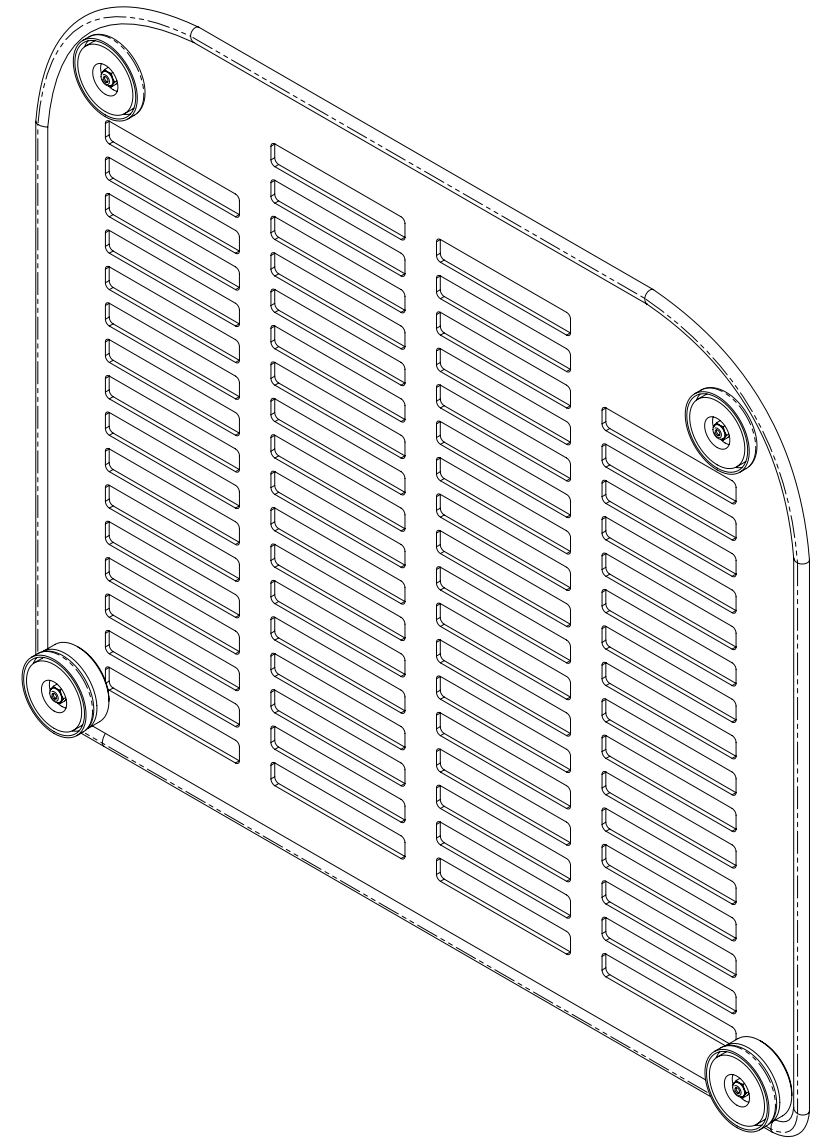
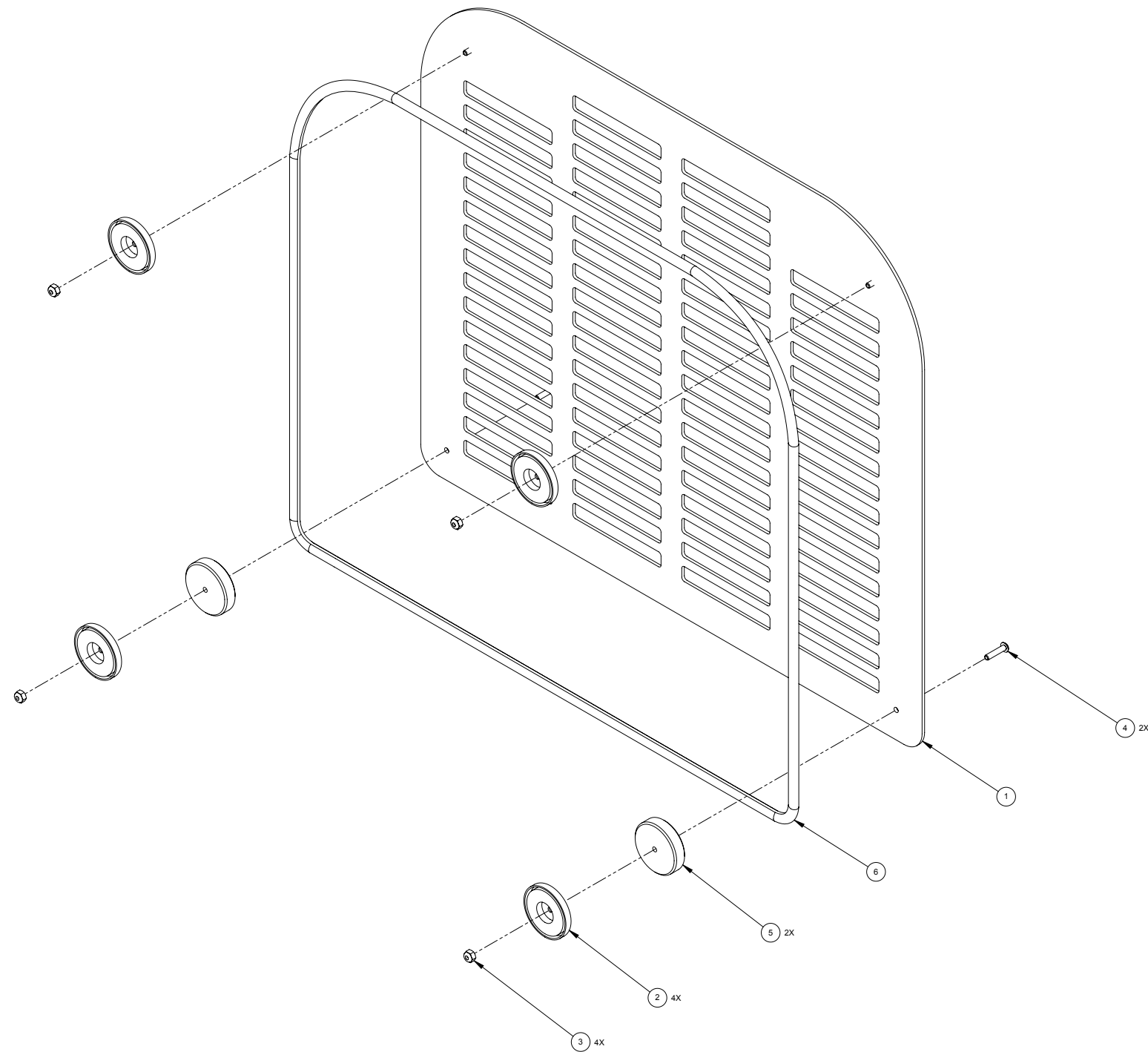

Side Cover Assembly Parts List

Item	Part Number	Description	Qty
1	000-041-903	Cover, Side - Machine - Coated	1
2	000-089-003	Magnet	4
3	000-094-034	Nut, #10-24UNC Nylock	4
4	000-143-746	Screw, 10-24 x 7/8 BTN Head SS	2
5	000-154-226	Spacer, 575 Side Cover	2
6	000-131-131	Trimlock, 3/8 X 1/8 Rubber Edge Trim	1 ft

Figure 9-26. Blower Heat Exchanger Assembly - View 1 of 2
610-005-741 Rev. C

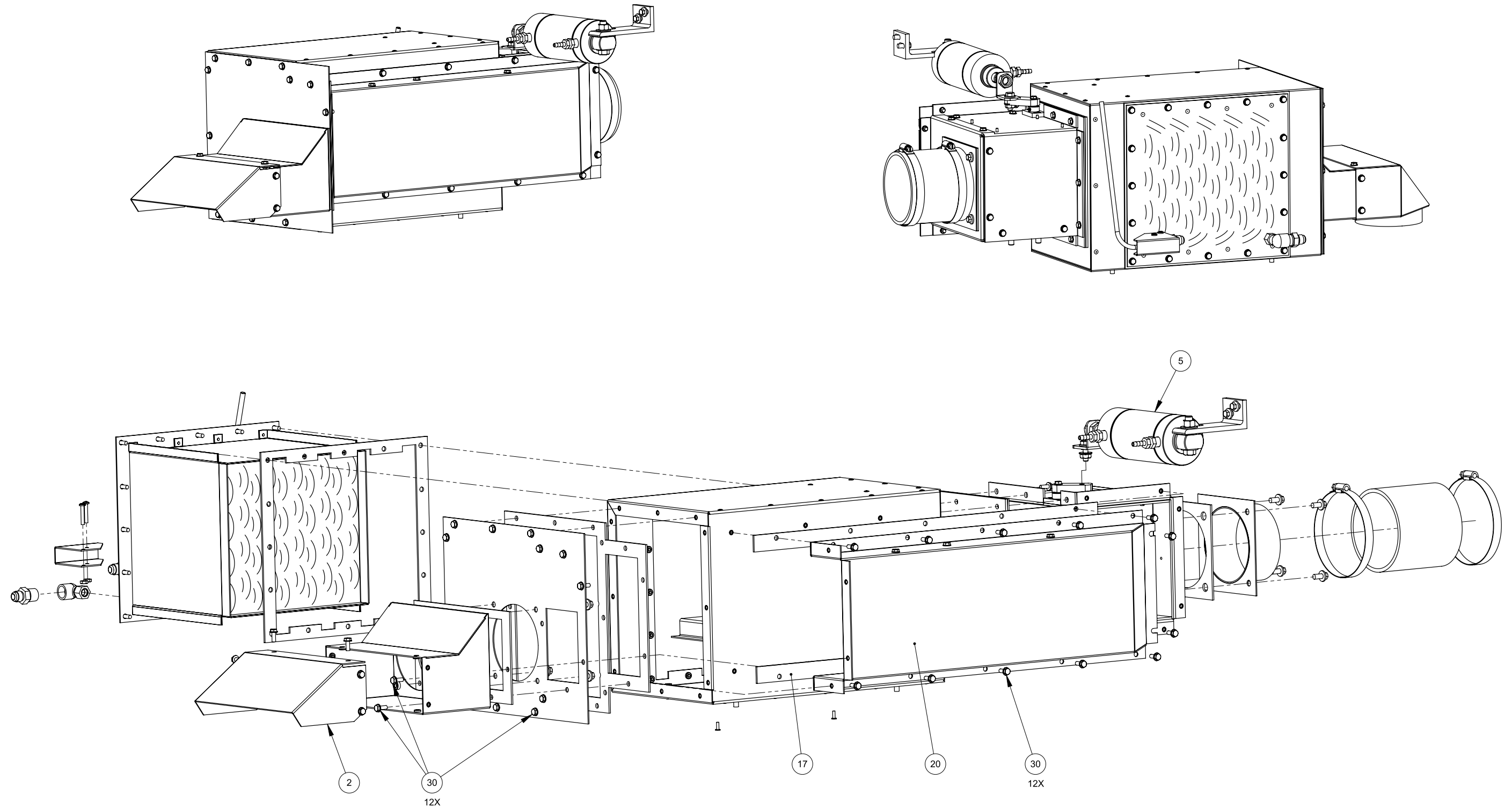

TITAN 575

Figure 9-27. Blower Heat Exchanger Assembly - View 2 of 2
610-005-741 Rev. C

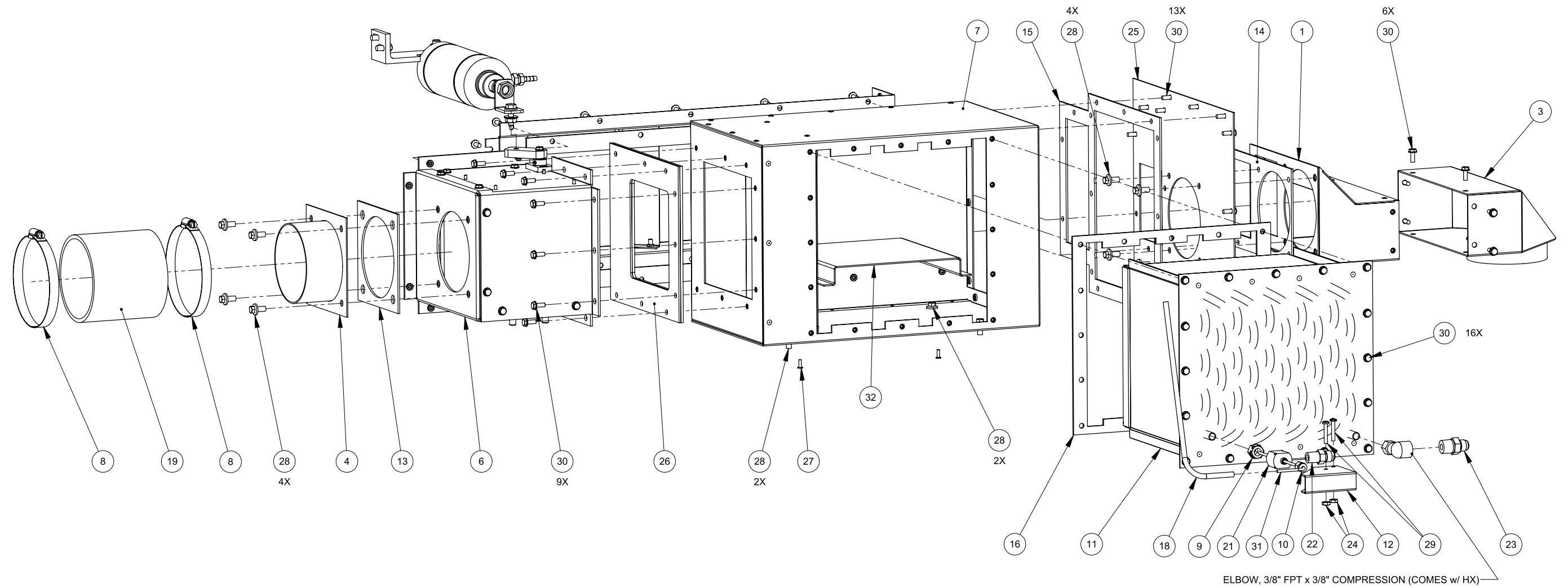

Blower Heat Exchanger Assembly Parts List

Item	Part Number	Description	Qty
1	000-001-155	Adapter, Exhaust Duct Outlet - Coated	1
2	000-001-191	Adapter, Exhaust Turn Down Deflector - Coated	1
3	000-001-186	Adapter, Exhaust Turndown - Coated	1
4	000-001-187	Adapter, Tank to N4.0" Blower Hose - Coated	1
5	610-014-741	Assembly, Actuator Valve	1
6	000-169-230	Assembly, Diverter Valve Box	1
7	000-013-075	Box, Heat Exchanger Inlet and Outlet Plenum	1
8	000-033-015	Clamp, 4" Hose	2
9	000-052-812	Compression, Fitting 1/4" FPT X 3/8" Tube	1
10	000-052-813	Compression, Fitting 1/4" NPT X 1/8" Tube	1
11	000-038-073	Core, Heat Exchanger 8" X 8"	1
12	000-041-482	Cover, RTD Sensor - Coated	1
13	000-057-210	Gasket, 4" Exhaust	1
14	000-057-225	Gasket, Exhaust Duct Outlet	1
15	000-057-223	Gasket, Front Plenum	1
16	000-131-015	Gasket, Heat Exchanger Core	1

Item	Part Number	Description	Qty
17	000-057-221	Gasket, Side Plenum	1
18	000-063-003	Harness Wrap, Hi Temp. 1/4" Gray	1
19	000-068-948	Hose, Ø4.0" I.D. X 3 Ply Silicone X 4" Lg.	1
20	000-042-064	Housing, Heat Exchanger Divert By-pass Assembled	1
21	000-052-815	Manifold, RTD 1/8" Comp X 3/8" Comp	1
22	000-052-533	Nipple, 3/8" JIC X 1/4" NPT	1
23	000-052-528	Nipple, 3/8" M JIC X 3/8" NPT	1
24	000-094-002	Nut, #8-32UNC Hex S/S	2
25	000-105-556	Plate, Plenum Front	1
26	000-105-698	Plate, Sealing Diverter w/ Gasket	1
27	000-140-017	Rivet, 1/8" X 3/8" Blind Pop S/S	2
28	000-143-141	Screw, 1/4"-20UNC X 1/2" Lg. Whiz Lock	12
29	000-143-545	Screw, #8-32UNC . X 1" Lg. Pph	2
30	000-143-583	Screw, #10-24UNC X 0.50" Lg. Hex Head Flange Z/P	58
31	000-149-566	Sensor, 6" - 90 Degree RTD	1
32	000-154-176	Spacer, Heat Exchanger Support - Bottom	1

NOTICE

Item 3 is only used with the Through Floor Kit option.

TITAN 575

Figure 9-28. Coolant Heat Exchanger Assembly - View 1 of 2
610-006-743 Rev. B

NOTICE

See Figure 9-1 for adhesive/sealant information.

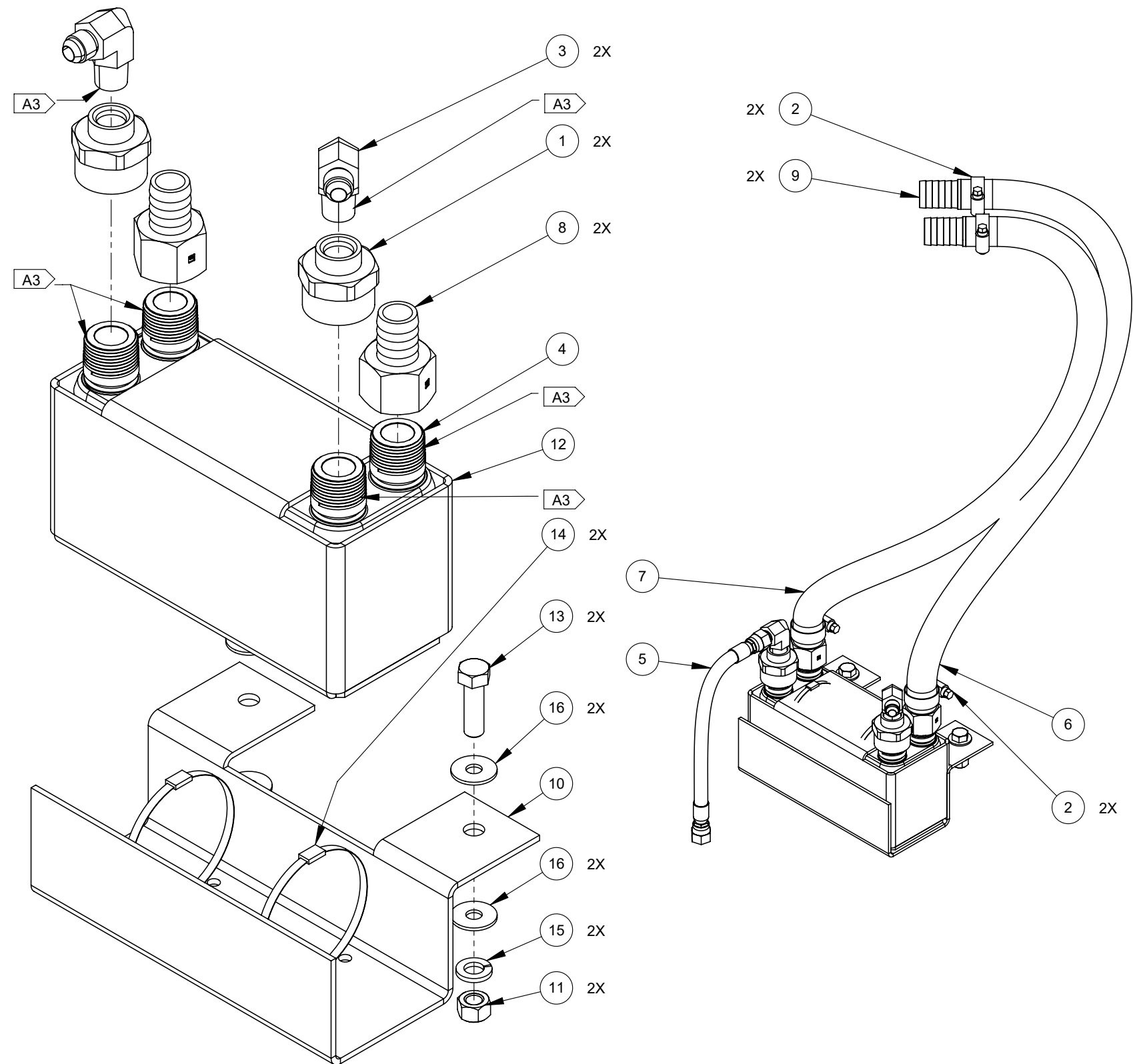
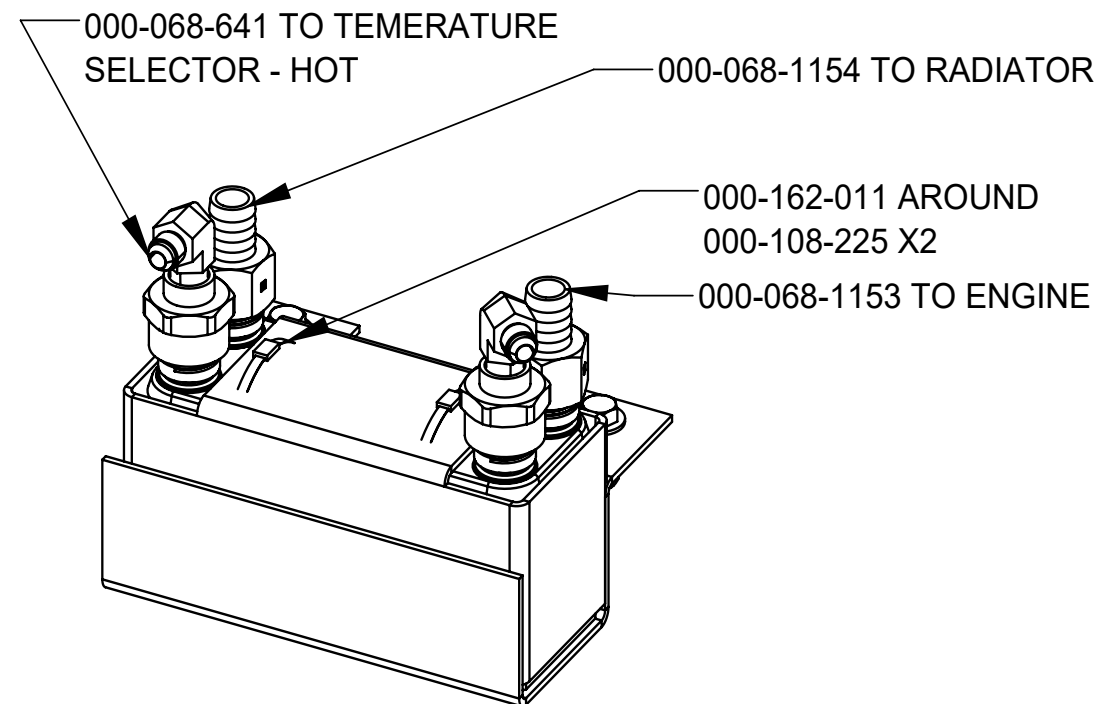

Figure 9-29. Coolant Heat Exchanger Assembly- View 2 of 2
610-006-743 Rev. B



Coolant Heat Exchanger Assembly Parts List

Item	Part Number	Description	Qty
1	000-052-951	ADAPTER, 3/4" FPT x 3/8" FPT BRASS	2
2	000-033-029	CLAMP, SIZE #12 HOSE	4
3	000-052-766	ELBOW, 3/8 NPT x 3/8 JIC	2
4	000-038-091	HEAT EXCHANGER, ALFA APX14	1
5	000-068-641	HOSE ASSY, 5/16" TEFLON X 10 LG w/JIC ENDS	1
6	000-068-1153	HOSE, 3/4" I.D. RUBBER X 26" LG.	1
7	000-068-1154	HOSE, 3/4" I.D. RUBBER X 28" LG	1
8	000-052-950	INSERT, #F1212 BRASS	2

Item	Part Number	Description	Qty
9	000-052-792	MENDER, 3/4" TO 1" BRASS	2
10	000-092-067	MOUNT, ALFA LEVEL AXP14 UNDER RADIATOR	1
11	000-094-014	NUT, 3/8"-16UNC HEX Z/P	2
12	000-108-225	PROTECTOR ALFA AXP14 HX	1
13	000-143-025	SCREW, 3/8"-16UNC x 1.25" LG. HEX HEAD GR. 8	2
14	000-162-011	TIE WRAP, 14.25" X 0.18" SS	2
15	000-174-021	WASHER, 3/8" LOCK	2
16	000-174-004	WASHER, 5/16" FLAT, USS	4

TITAN 575

Figure 9-30. Diverter Valve Assembly
000-169-230 Rev. E

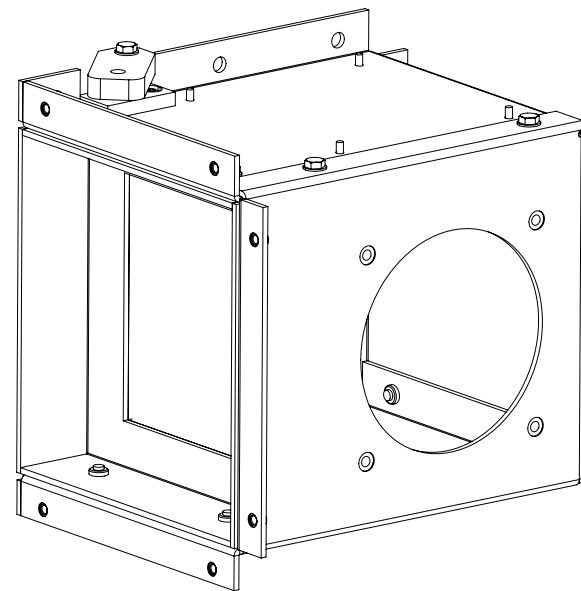

Diverter Valve Box Assembly Parts List

Item	Part Number	Description	Qty
1	000-020-069	BUSHING, FLAPPER - DIVERTER - MACHINED	2
2	000-020-073	COLLAR, DIVERTER ALIGNMENT	1
3	000-057-220	GASKET, DIVERTER BAFFLE	1
4	000-042-067	HOUSING, BAFFLE - DIVERTER - FABRICATED	1
5	000-042-066	HOUSING, BOTTOM & SIDE - DIVERTER - FAB	1
6	000-042-065	HOUSING, TOP & SIDE - DIVERTER - FABRICATED	1
7	000-085-031	LINKAGE, DIVERTER ACTUATION - COATED	1
8	000-105-552	PLATE, FLAPPER DIVERTER-COATED	1
9	000-108-151	PROTECTOR, EXHAUST DIVERTER - FABRICATED	1
10	000-140-017	RIVET, 1/8" x 3/8" BLIND POP s/s	4
11	000-143-107	SCREW, #10-24UNC x 0.375" LG. BH SD GRD. 8	1
12	000-143-583	SCREW, #10-24UNC x 0.50" LG. HH FLANGE Z/P	2
13	000-143-705	SCREW, #10-24UNC x 0.375" LG. WHIZ HEAD	10
14	000-143-111	SET SCREW, #10-24UNC x 0.25" LG.	2
15	000-174-014	WASHER, #10 LOCK	3

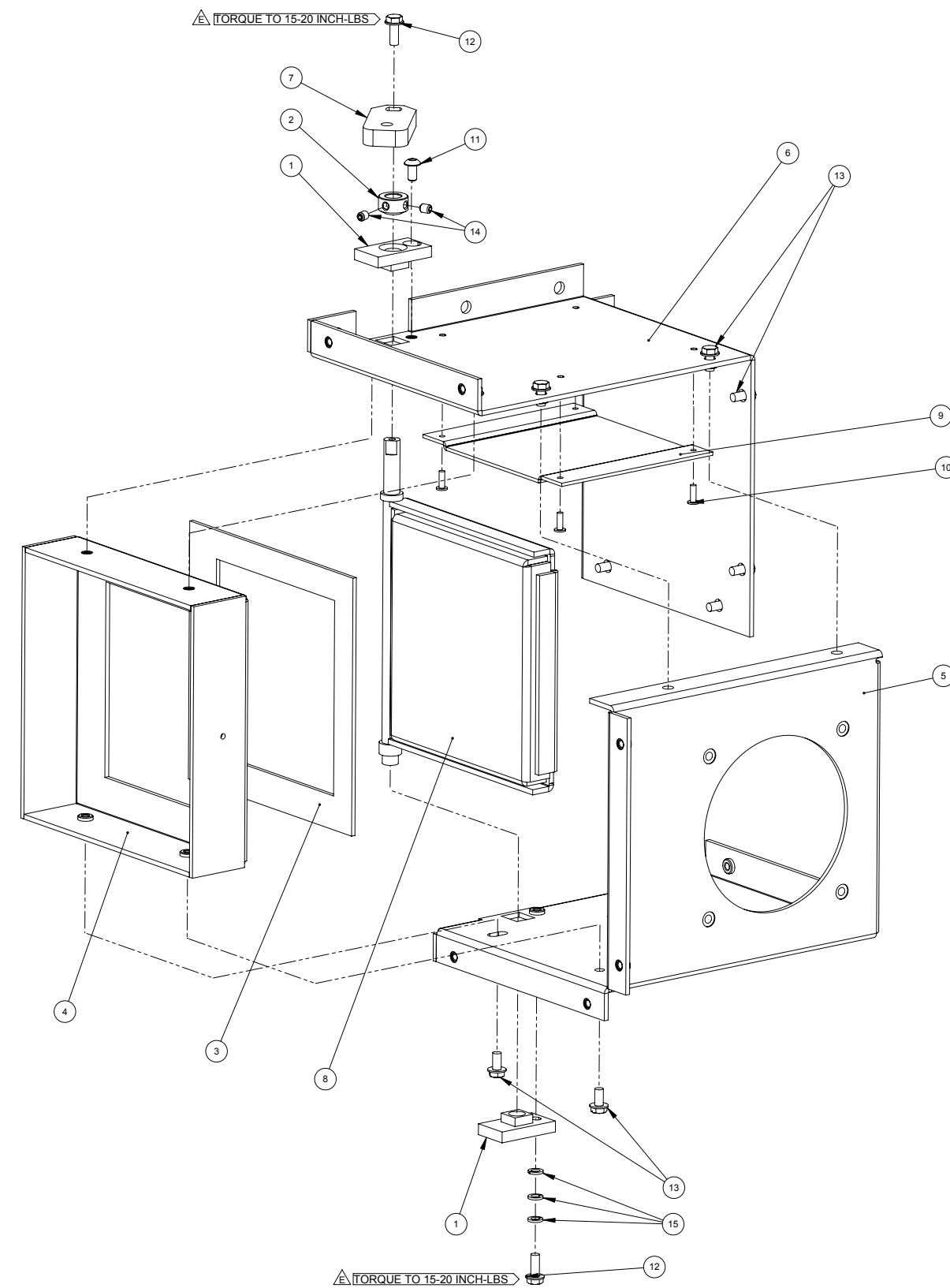
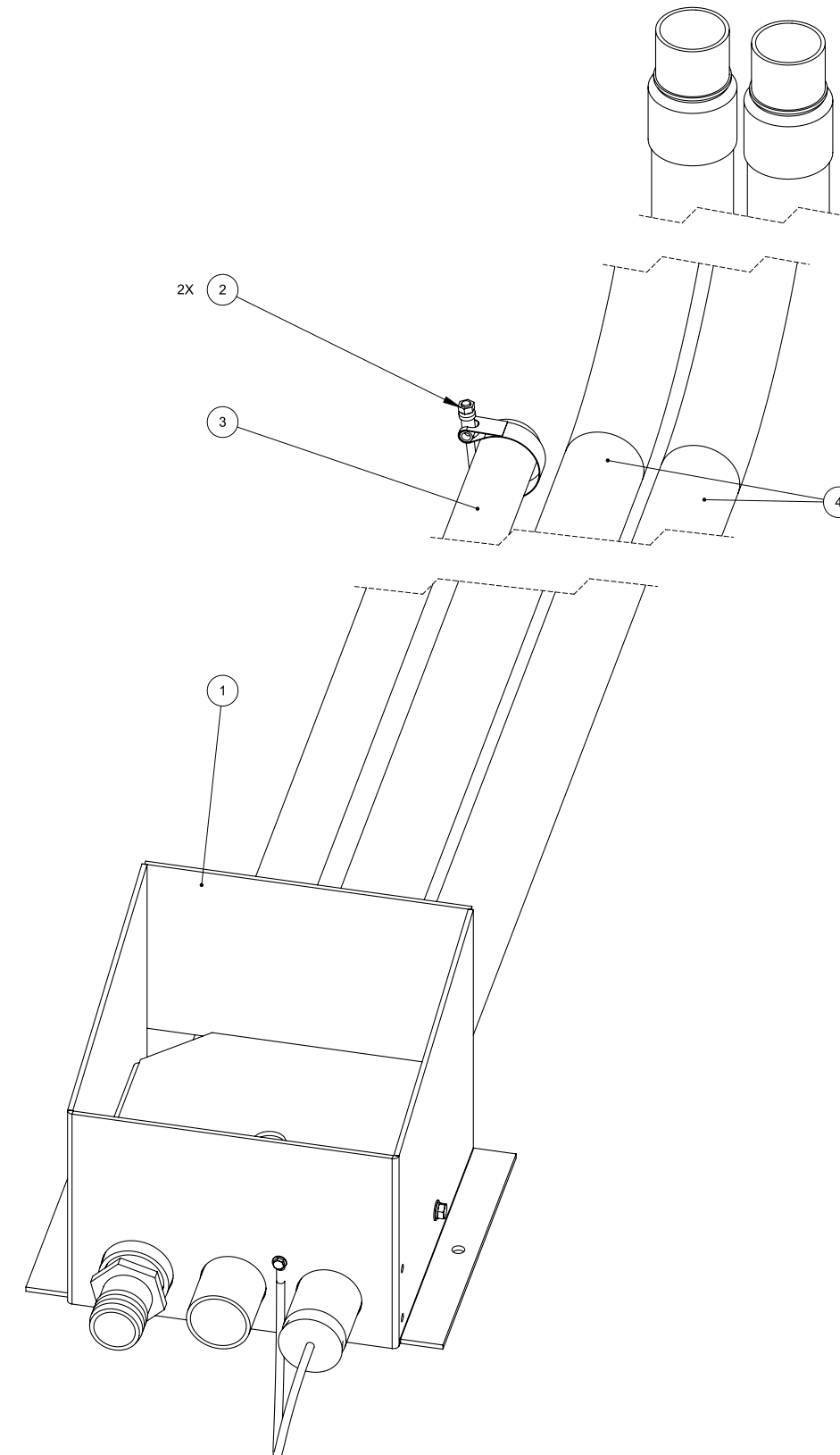
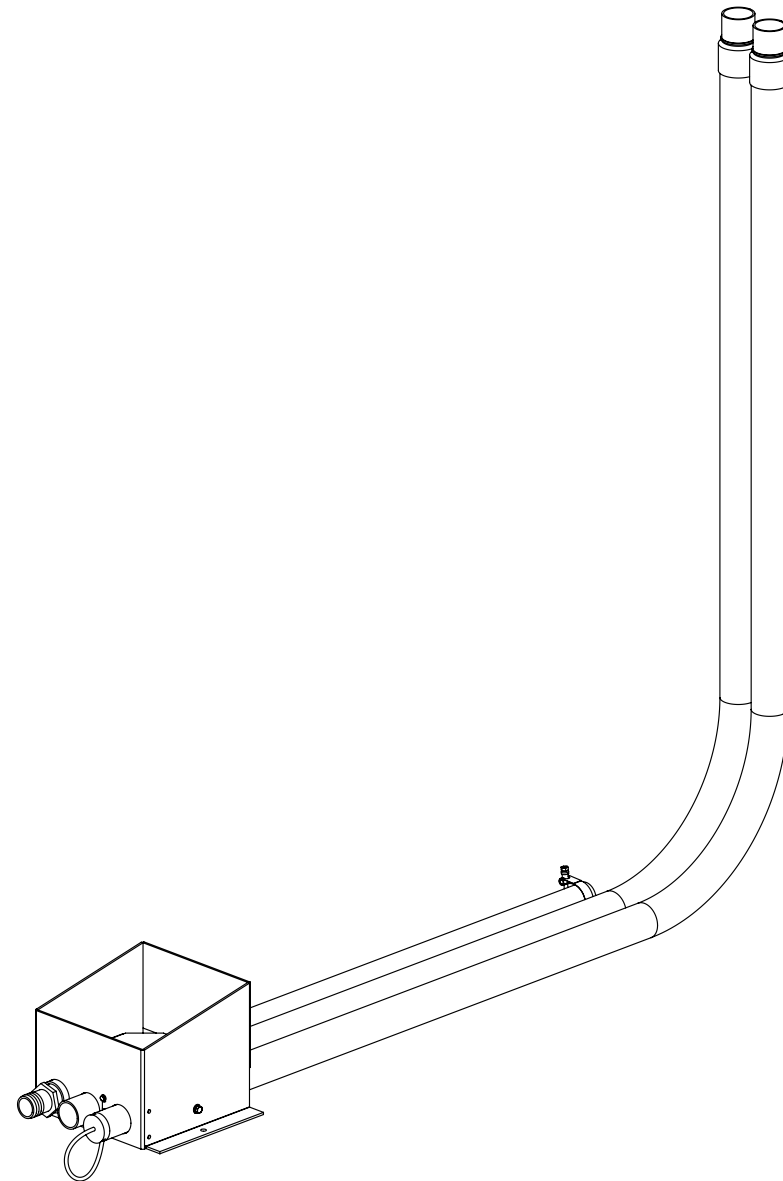

Figure 9-31. Chemical Jug Tray/Hose/Connection Package
000-079-048 Rev. B



Chemical Jug Tray/Hose/Connection Package Parts List

Item	Part Number	Description	Qty
1	610-015-040	Assembly, Chemical Jug Tray	1
2	000-033-063	Clamp, 2" T-Bolt	2
3	000-068-882	Hose, 1.5" I.D. Red Stripe X 48" Lg.	1
4	000-068-141	Hose, 2" X 10 ft Vacuum w/ Cuffs	2

TITAN 575

Figure 9-32. Chemical Jug Tray Assembly
610-015-040 Rev. E

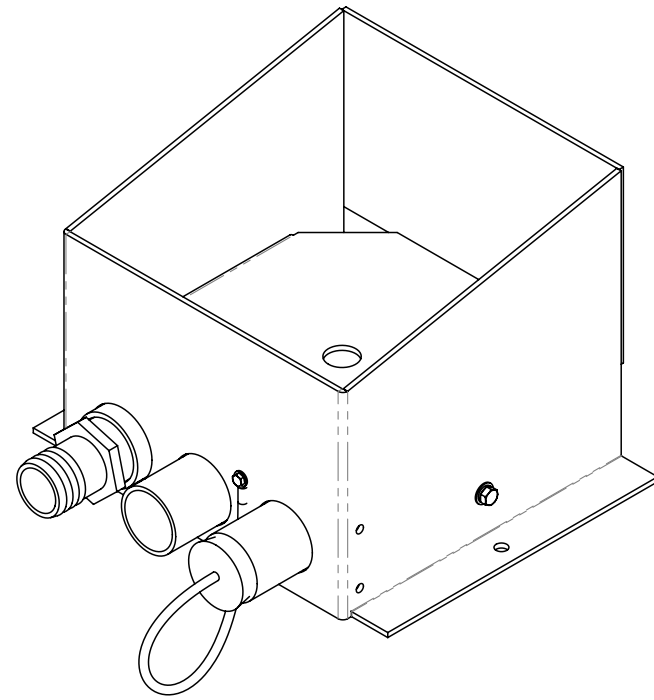

Chemical Jug Tray Assembly Parts List

Item	Part Number	Description	Qty
1	000-143-001	Screw, 1/4"-20 Unc X 0.75" Lg. Hex Head	2
2	000-143-166	Screw, #10-24 Unc X 0.375" Lg. Hex Head	1
3	000-166-023	Tray, Outer Chemical Jug - Coated	1
4	000-166-025	Tray, Chemical Jug - Inner - Coated	1
5	000-078-039	Vacuum Inlet Stopper	1
6	000-174-001	Washer, #10 Flat	1
7	000-174-003	Washer, 1/4" Flat	2
8	000-174-019	Washer, 1/4" Lock	2

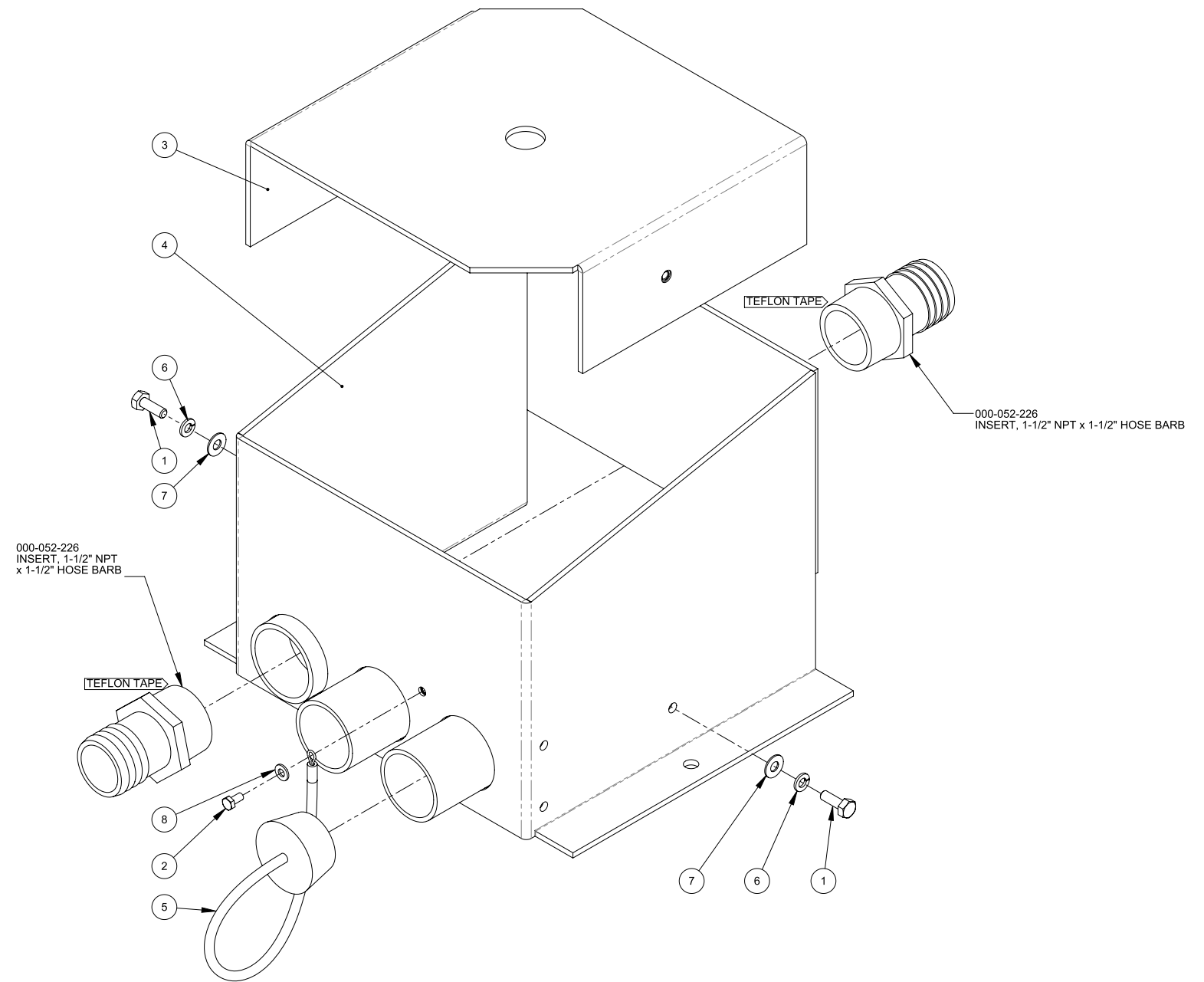

NOTICE

For the Chemical Jug Tray/Hose/Connection Package, order P/N 000-079-048 (see Figure 9-32).

Figure 9-33. By-Pass Valve Assembly - View 1 of 2
610-009-741 Rev. B

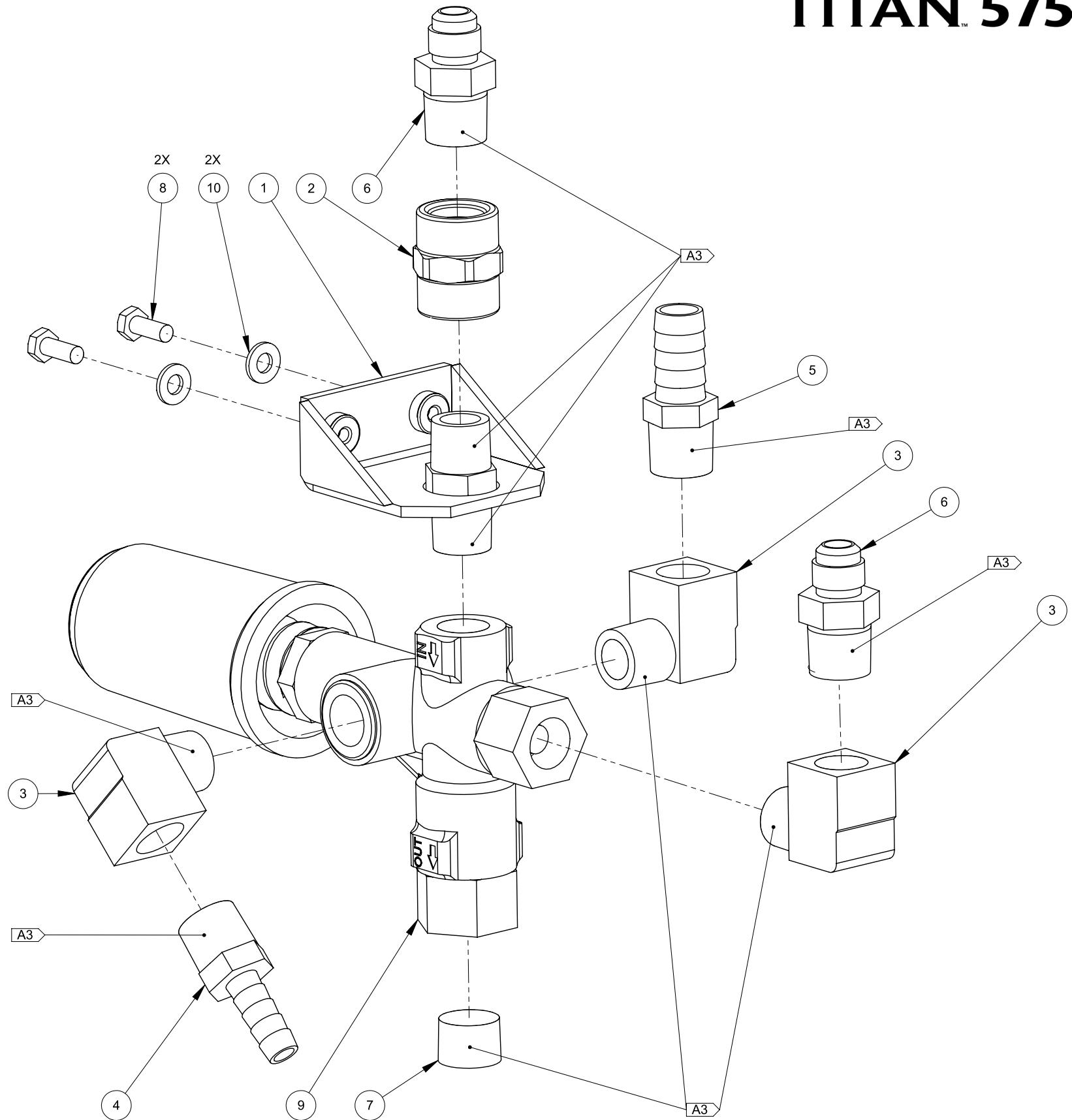
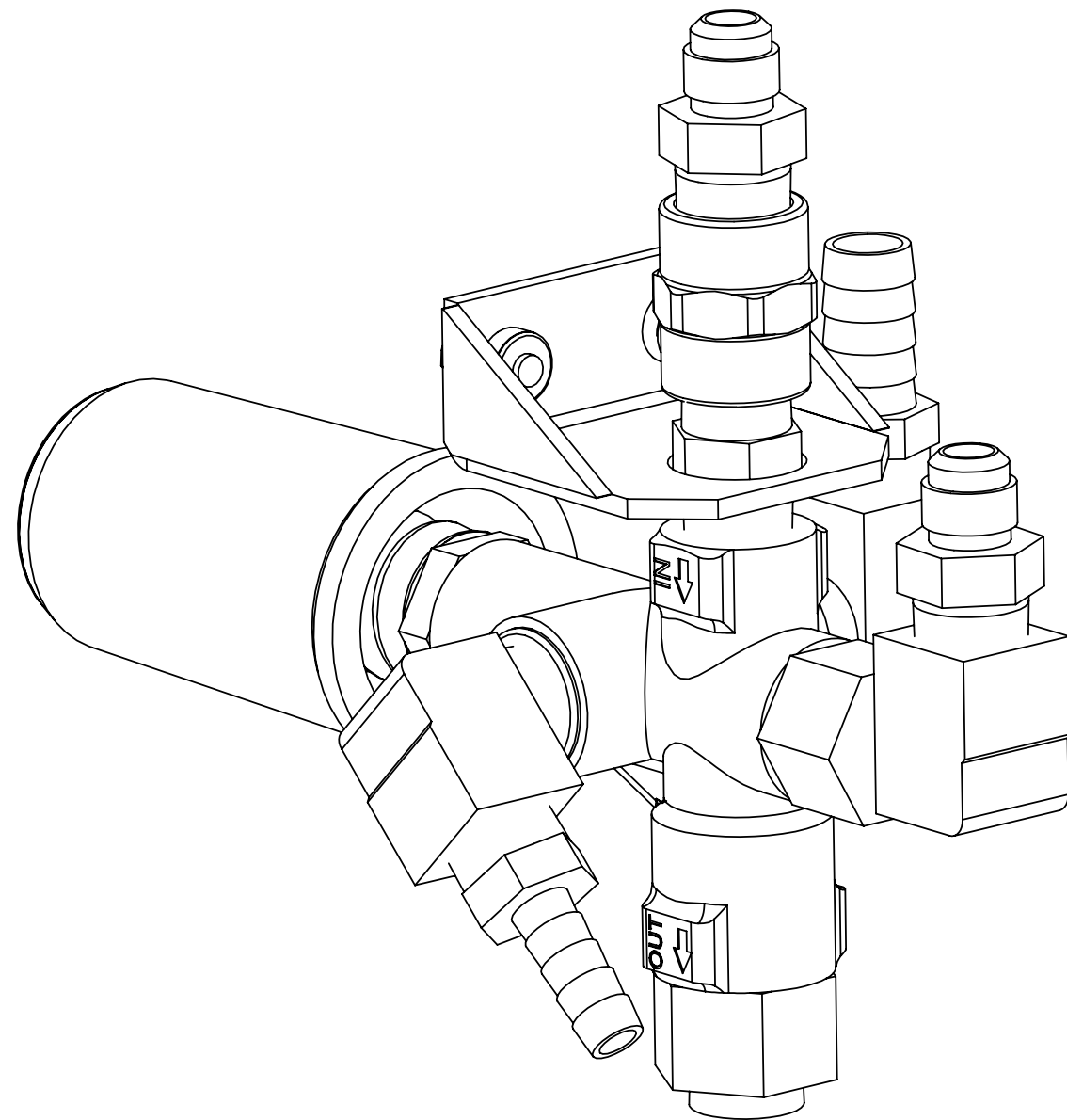

NOTICE

See Figure 9-1 for sealant/adhesive information.

TITAN 575

Figure 9-34. By-Pass Valve Assembly - View 2 of 2
610-009-741 Rev. B

By-Pass Valve Assembly Parts List

Item	Part Number	Description	Qty
1	000-015-515	Bracket, By-Pass Valve Mount - Weldment	1
2	000-052-414	Coupler, 3/8" FPT Brass	1
3	000-052-086	Elbow, 3/8" NPT Street	3
4	000-052-104	Insert, #66 (3/8" NPT X 3/8" Barb)	1
5	000-052-105	Insert, #68 (3/8" NPT X 1/2" Barb)	1
6	000-052-528	Nipple, 3/8" M JIC X 3/8" NPT	2
7	000-106-008	Plug, 3/8" NPT Allen Head	1
8	000-143-126	Screw, #10-24UNC X 0.50" Lg. Hex Head	2
9	000-169-351	Valve, Pressure Regulator-Modified *	1
10	000-174-001	Washer, #10 Flat	2

NOTICE

* Order P/N 000-078-582 for the valve repair kit.

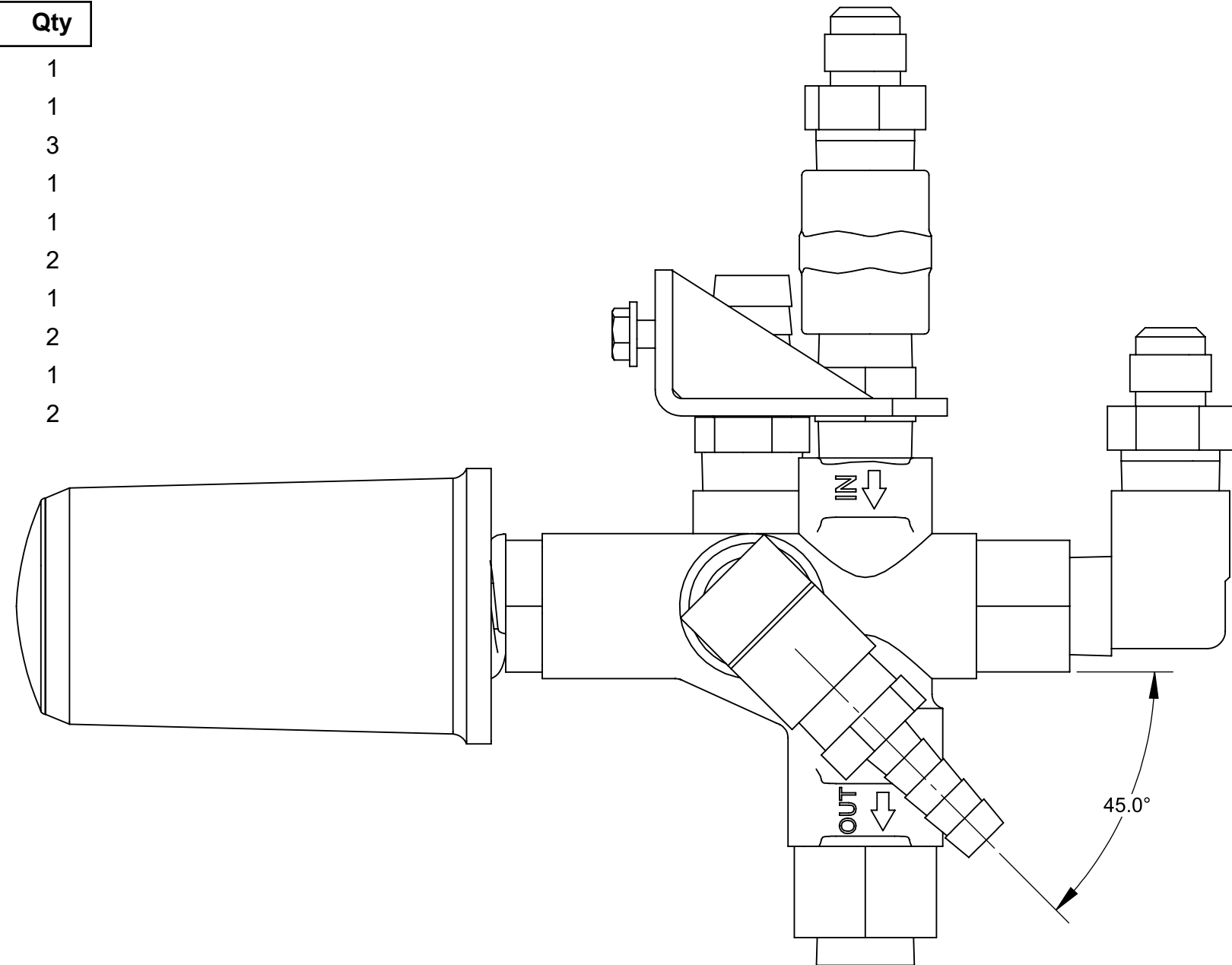
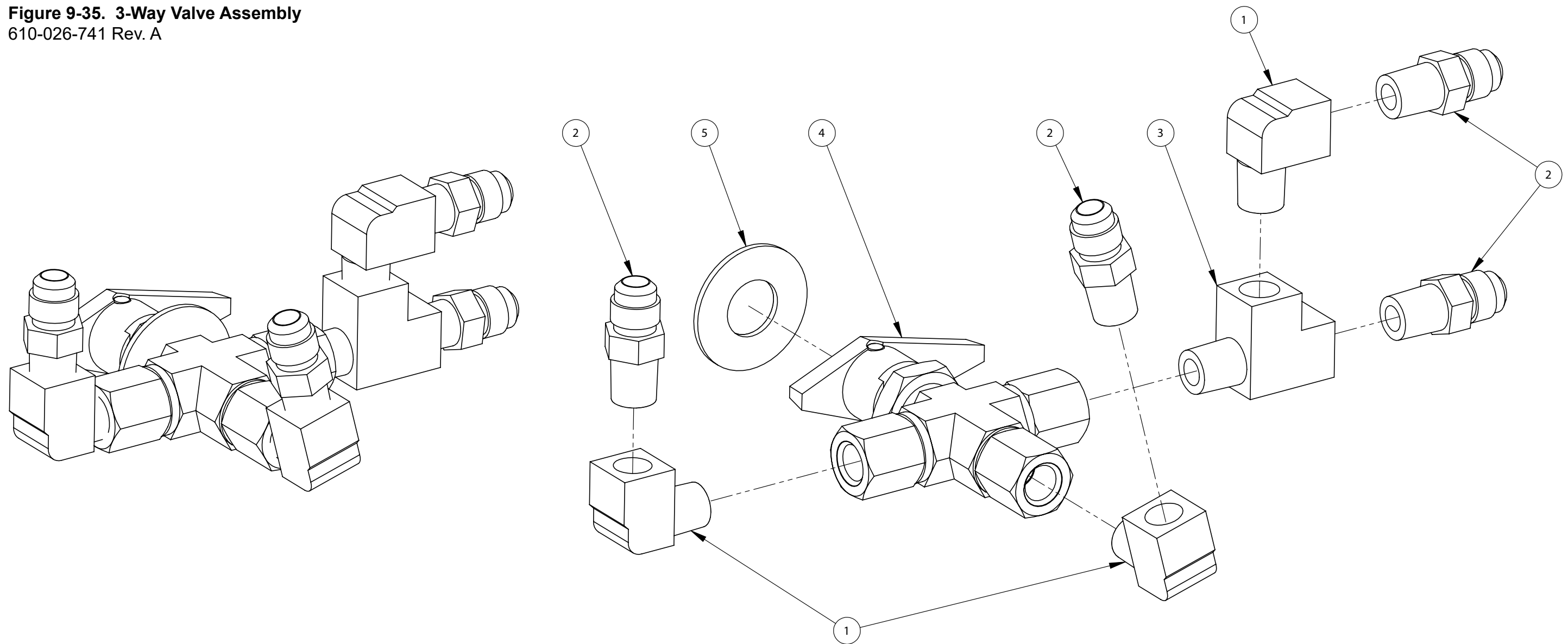

Figure 9-35. 3-Way Valve Assembly
610-026-741 Rev. A



3-Way Valve Assembly Parts List

Item	Part Number	Description	Qty
1	000-052-085	Elbow, 1/4" NPT Street	3
2	000-052-533	Nipple, 3/8" JIC X 1/4" NPT	4
3	000-052-090	Tee, 1/4" NPT Branch M-F-F	1
4	000-169-213	Valve, 3-Way 1/4" FPT	1
5	000-174-034	Washer, 0.688" I.D. X 1.50" O.D. X 0.078" Thk.	1

TITAN 575

Figure 9-36. Actuator Valve Assembly
610-014-741 Rev. D

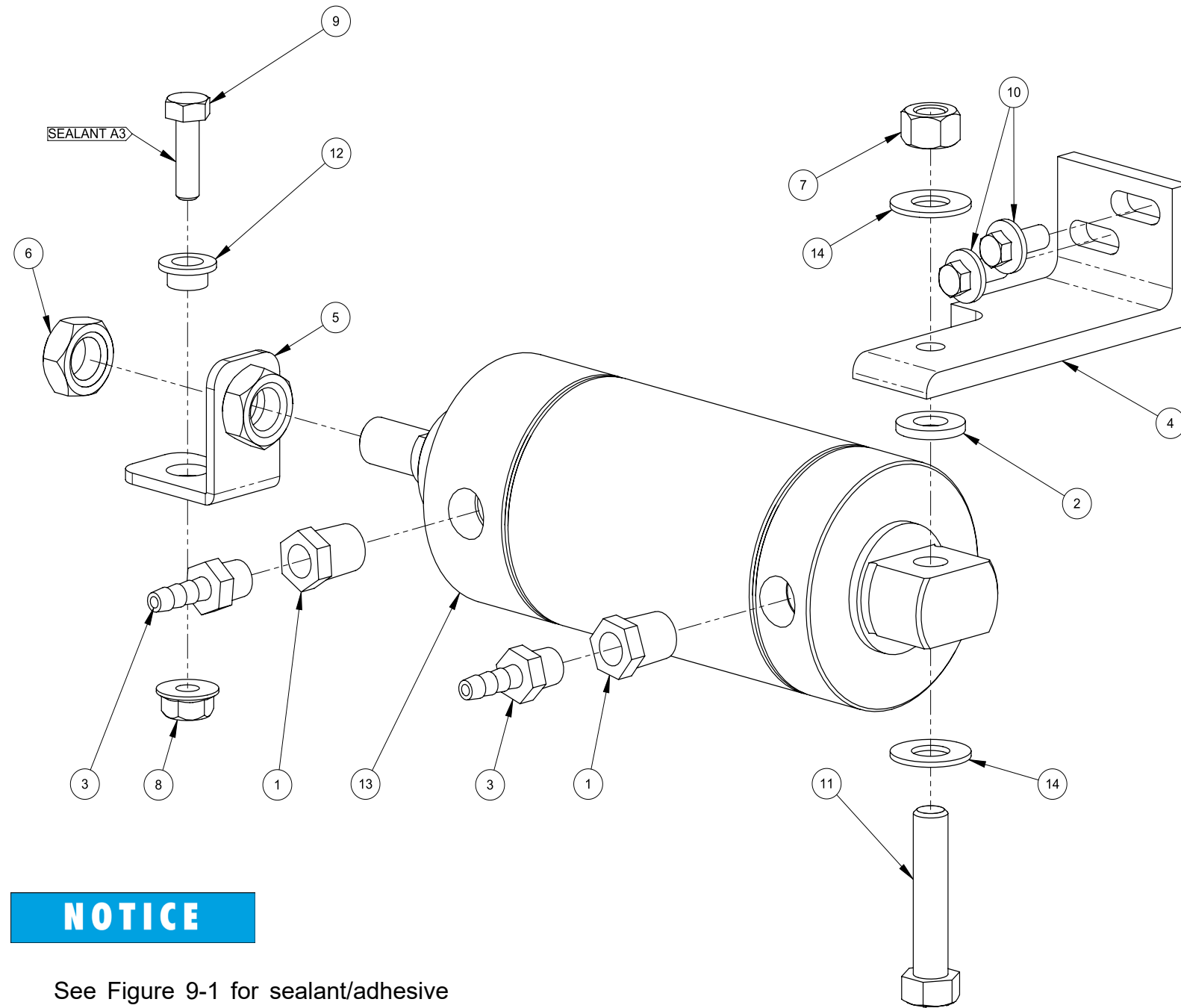

Actuator Valve Assembly Parts List

Item	Part Number	Description	Qty
1	000-052-059	Bushing, 1/4" MPT X 1/8" FPT	2
2	000-057-224	Gasket, Actuator	1
3	000-052-293	Insert, #23 (1/8" NPT X 3/16" Barb)	2
4	000-042-069	Mount Air Cylinder - Coated	1
5	000-042-070	Mount, Air Cylinder Extension - Coated	1
6	000-094-122	Nut, 1/2"-20UNF Hex Jam	1
7	000-094-014	Nut, 3/8"-16UNC Hex Z/P	1
8	000-094-117	Nut, 5/16"-18UNC Hex Spirallock	1
9	000-143-160	Screw, 1/4"-20UNC X 0.875" Lg. Hex Head Grade 5	1
10	000-143-141	Screw, 1/4"-20UNC X 1/2" Lg. Whiz Lock	2
11	000-143-022	Screw, 3/8-16UNC X 1.75" Hex Head - Grade 8	1
12	000-154-207	Spacer, Ø0.625 X 0.25" Lg. Flanged	1
13	000-169-225	Valve, Ø2.5" Air Cylinder	1
14	000-174-032	Washer, 3/8" Flat	2

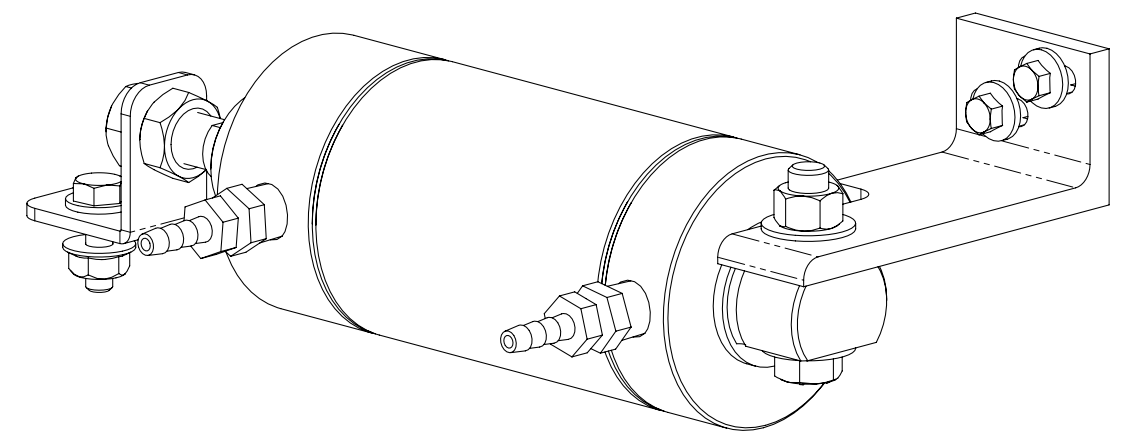

NOTICE

See Figure 9-1 for sealant/adhesive information.

Figure 9-37. Hi Pressure Manifold Assembly
610-008-741 Rev. B

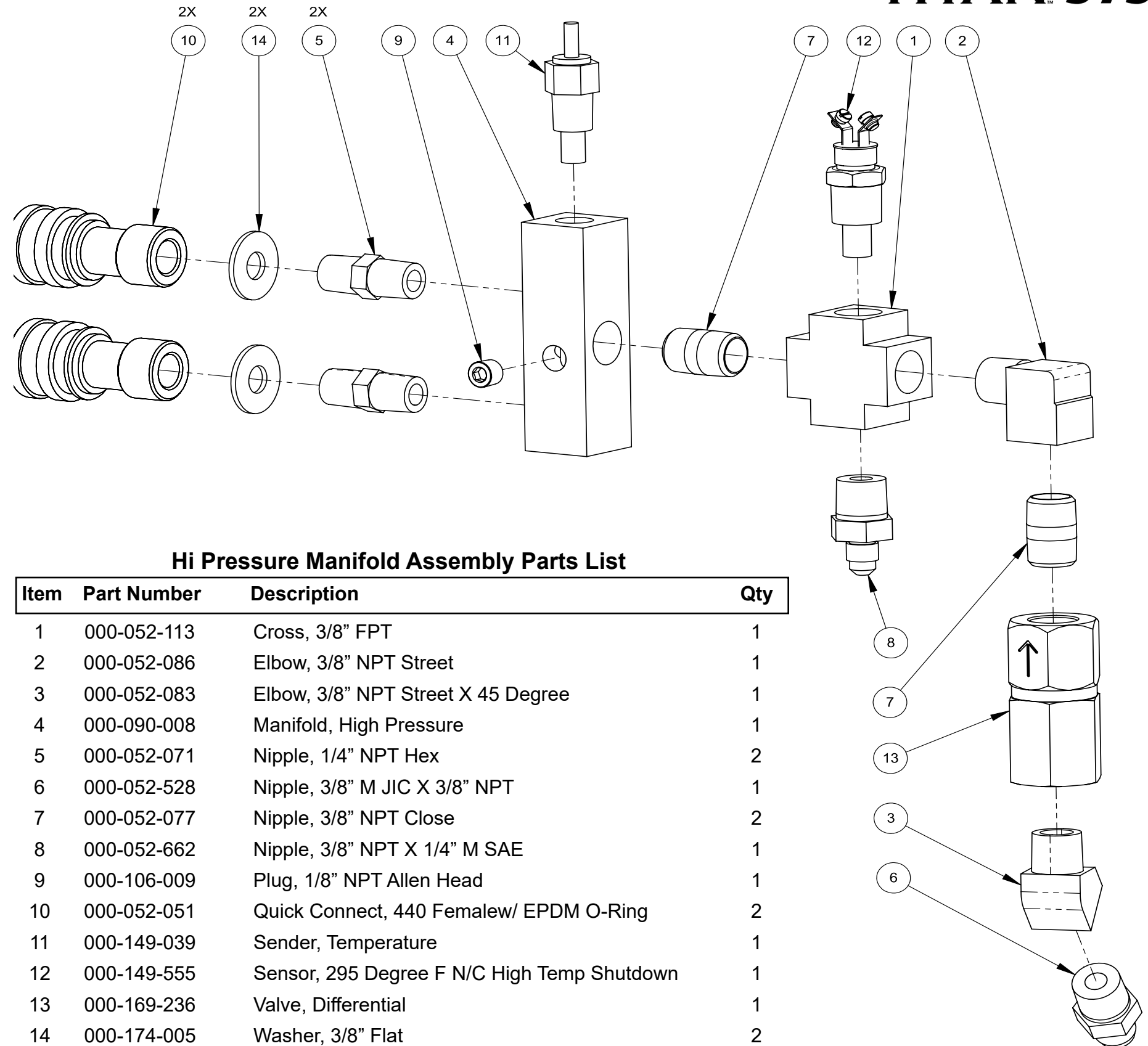
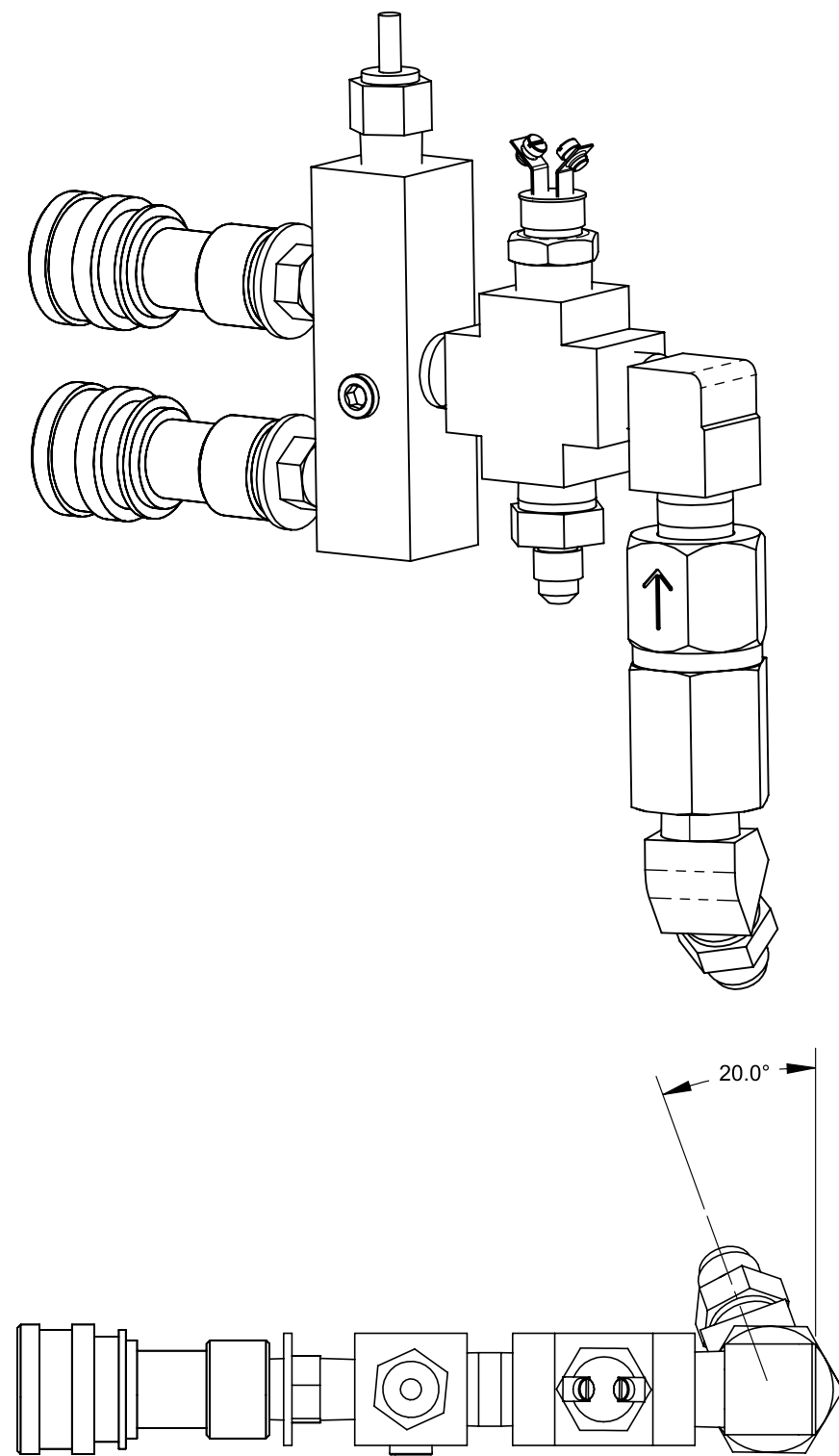

Hi Pressure Manifold Assembly Parts List

Item	Part Number	Description	Qty
1	000-052-113	Cross, 3/8" FPT	1
2	000-052-086	Elbow, 3/8" NPT Street	1
3	000-052-083	Elbow, 3/8" NPT Street X 45 Degree	1
4	000-090-008	Manifold, High Pressure	1
5	000-052-071	Nipple, 1/4" NPT Hex	2
6	000-052-528	Nipple, 3/8" M JIC X 3/8" NPT	1
7	000-052-077	Nipple, 3/8" NPT Close	2
8	000-052-662	Nipple, 3/8" NPT X 1/4" M SAE	1
9	000-106-009	Plug, 1/8" NPT Allen Head	1
10	000-052-051	Quick Connect, 440 Femalew/ EPDM O-Ring	2
11	000-149-039	Sender, Temperature	1
12	000-149-555	Sensor, 295 Degree F N/C High Temp Shutdown	1
13	000-169-236	Valve, Differential	1
14	000-174-005	Washer, 3/8" Flat	2

TITAN 575

Figure 9-38. Differential Check Valve Assembly
000-169-236 Rev. B

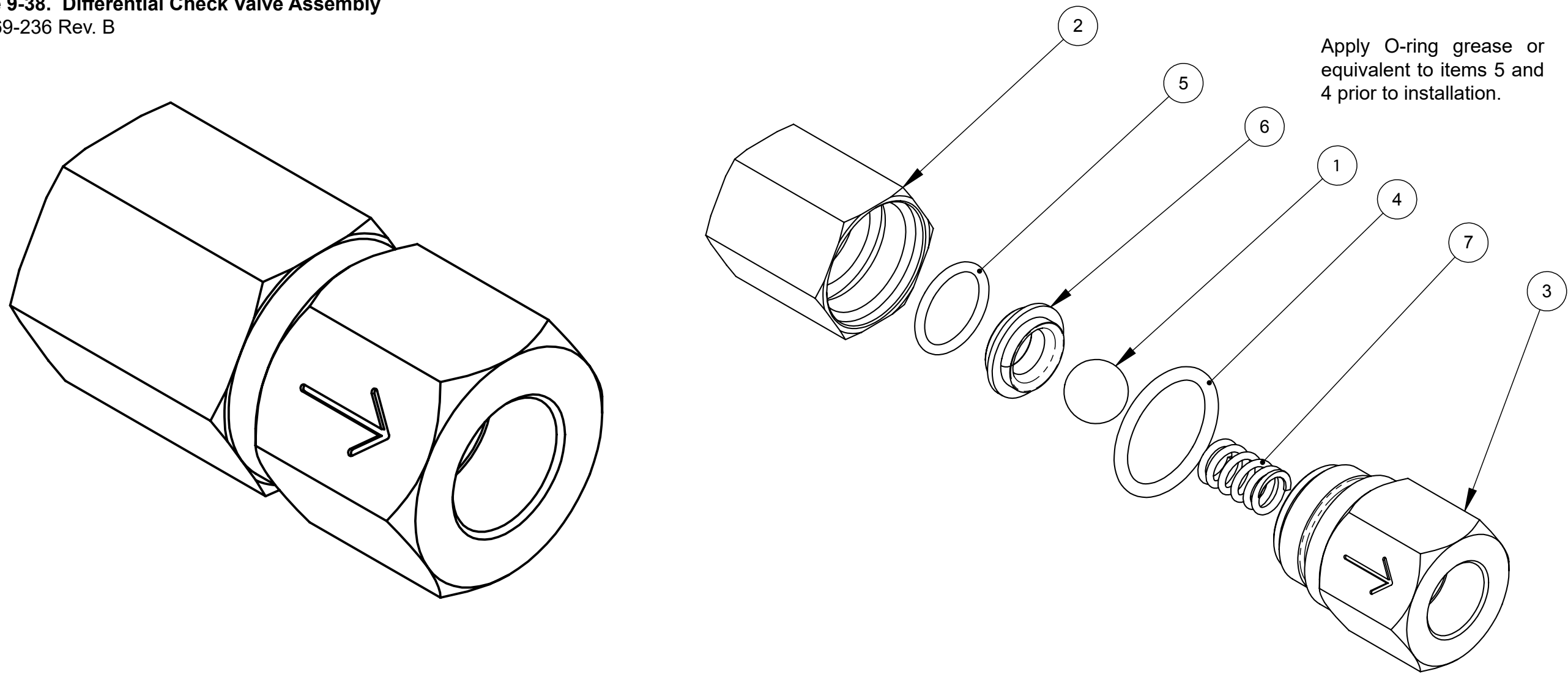

Differential Check Valve Assembly Parts List

Item	Part Number	Description	Qty
1	000-005-012	Ball, 0.500 Dia Stainless Steel	1
2	000-107-258	Body, Differential Check Valve	1
3	000-106-180	Cap, Differential Check Valve	1
4	000-097-056	O-Ring, Check Valve Plug, An Size -118-Vit	1

Item	Part Number	Description	Qty
5	000-097-054	O-Ring, Chem. Pump Valve Viton-Parker 2-114	1
6	000-148-012	Seat, Differential Check Valve	1
7	000-155-106	Spring, Differential Check Valve	1

TITAN 575

Figure 9-39. 70 Gallon Universal Recovery Tank (URT) Assembly
610-003-741 Rev. E

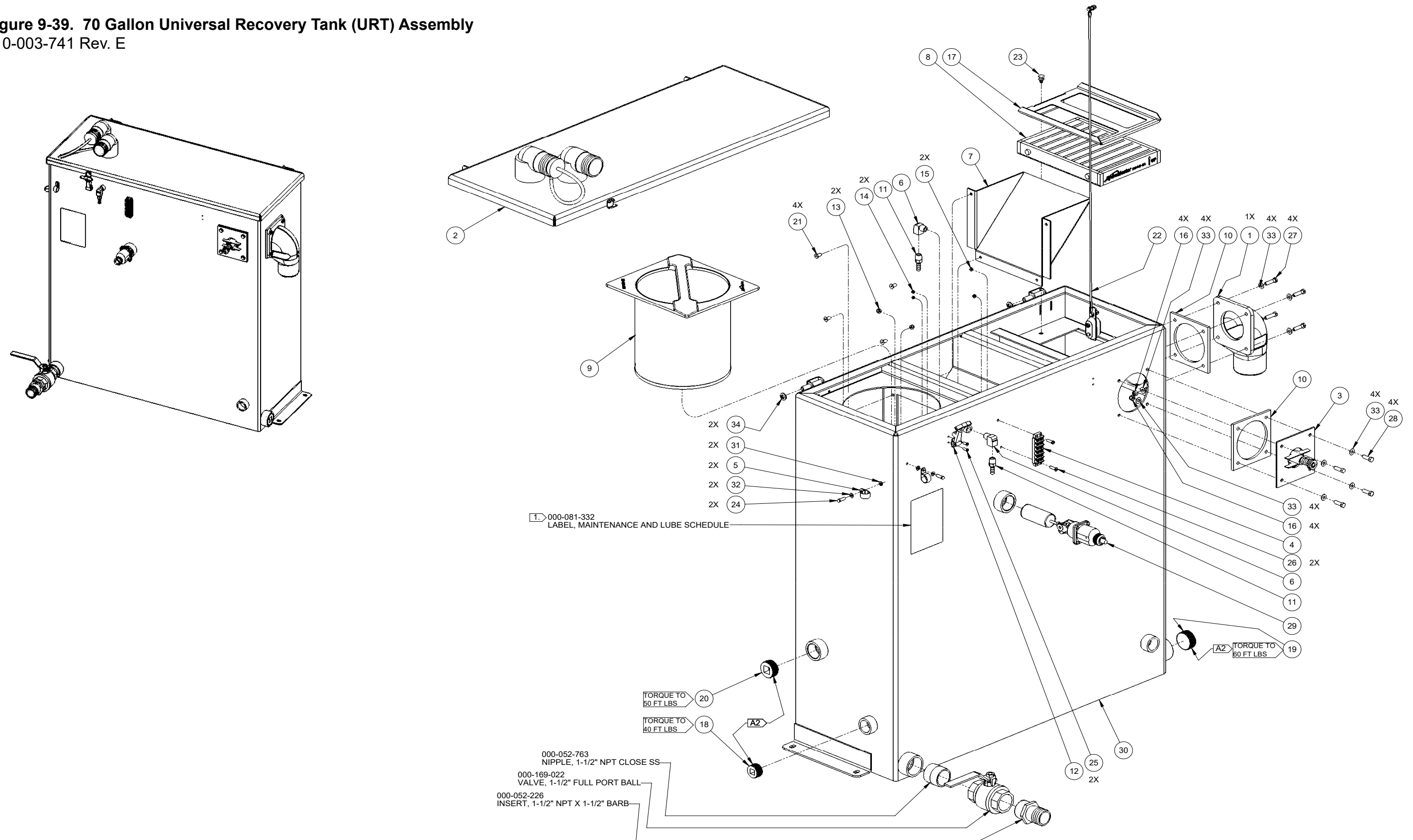

TITAN 575

70 Gallon Universal Recovery Tank (URT) Assembly Parts List

Item	Part Number	Description	Qty
1	000-001-135	ADAPTER, Ø3.0 TANK TO x 90° BLOWER HOSE - CASTING	1
2	610-029-010	ASSEMBLY, COVER, 70 GAL, DUAL VAC, URT E-01	1
3	610-026-724	ASSEMBLY, VACUUM RELIEF VALVE - URT	1
4	000-012-002	BLOCK, 6 POST TERMINAL	1
5	000-033-023	CLAMP, 3/4" NYLON HOSE	2
6	000-052-085	ELBOW, 1/4" NPT STREET	2
7	000-049-154	FILTER, AIR DEFLECTOR, URT - FABRICATED	1
8	000-049-153	FILTER, FLAT - UNIVERSAL RECOVERY TANK	1
9	000-049-152	FILTER, RECOVERY TANK BASKET	1
10	000-057-206	GASKET, ADAPTER - URT	2
11	000-052-100	INSERT,#44	2
12	000-086-008	LATCH, BUNGEE	1
13	000-094-034	NUT, #10-24UNC HEX NYLOCK	2
14	000-094-063	NUT, #6-32UNC HEX NYLOCK	2
15	000-094-059	NUT, #8-32UNC HEX NYLOCK	2
16	000-094-009	NUT, 1/4"-20UNC NYLOCK	8
17	000-105-785	PLATE, BLOWER FLAT FILTER - ZR	1

Item	Part Number	Description	Qty
18	000-106-049	PLUG, 1" NPT BRONZE	1
19	000-106-019	PLUG, 1-1/2" NPT BRONZE	1
20	000-106-046	PLUG, 1-1/4" NPT BRONZE	1
21	000-140-023	RIVET, AB8-6A ALUMINUM POP	4
22	000-079-226	SACRIFICIAL ANODE, MAGNESIUM	1
23	000-143-787	SCREW THUMB 1/4-20X3/8	1
24	000-143-132	SCREW, #10-24UNC x 0.75" LG. HEX HEAD	2
25	000-143-539	SCREW, #6-32UNC x 0.50" LG. BUTTON HEAD	2
26	000-143-051	SCREW, #8-32UNC x 0.75" LG. BINDER HEAD	2
27	000-143-010	SCREW, 1/4"-20UNC X 1.25" LG. HEX HEAD S/S	4
28	000-143-002	SCREW, 1/4"-20UNC x 1.00" LG. HEX HEAD	4
29	000-157-091	SWITCH, FLOAT LEVER	1
30	000-159-128	TANK, 70 GALLON URT - COATED E01	1
31	000-174-036	WASHER, #10 FLAT RUBBER BACKED	2
32	000-174-001	WASHER, #10 FLAT	2
33	000-174-003	WASHER, 1/4" FLAT S/S	16
34	000-174-029	WASHER, 3/8" FLAT RUBBER BACKED	2

Figure 9-40. 70 Gallon Universal Recovery Tank (URT) Cover Assembly
610-029-010 Rev. B

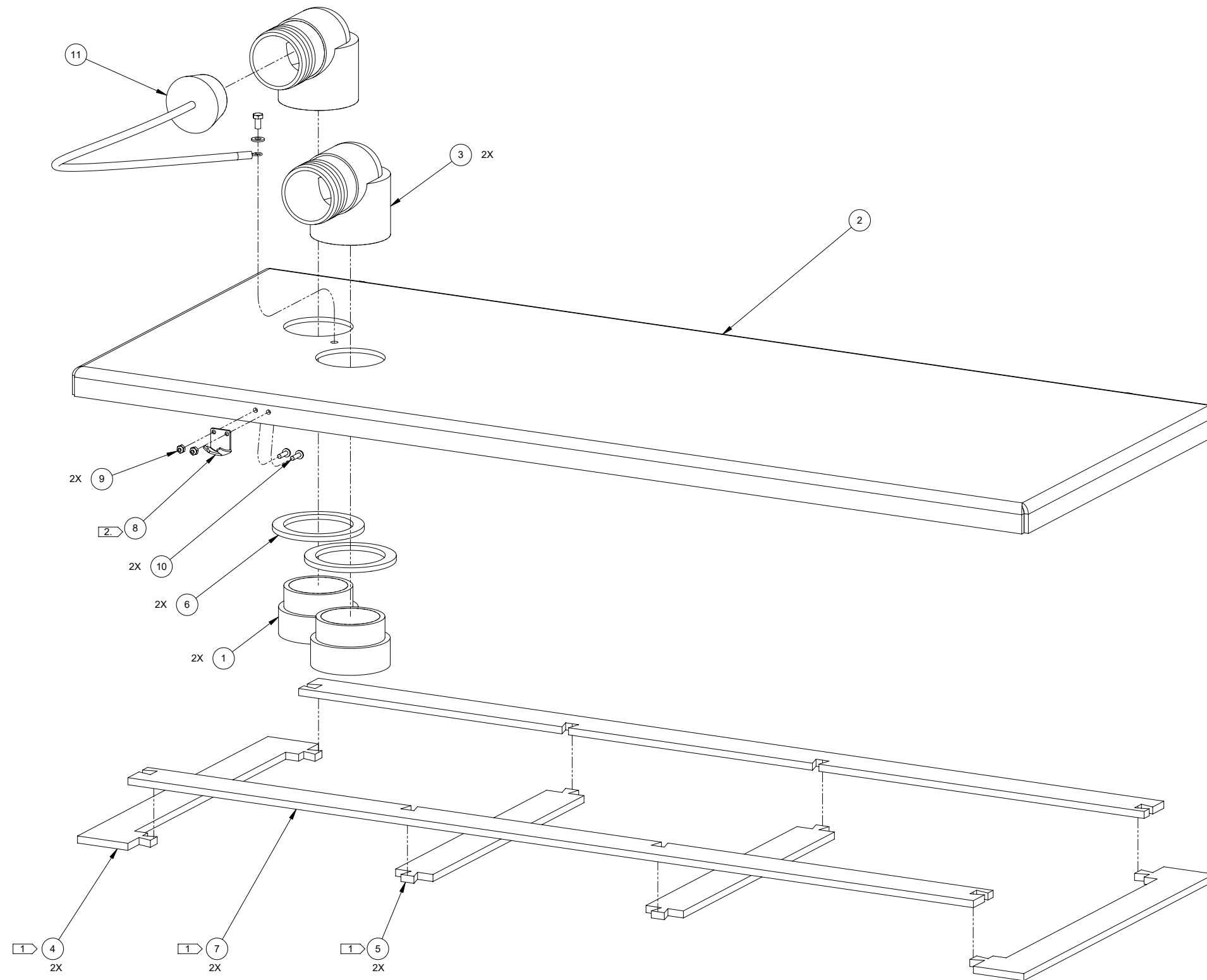

TITAN 575

70 Gallon Universal Recovery Tank (URT) Cover Assembly Parts List

Item	Part Number	Description	Qty
1	000-052-219	Adapter, 2" NPT X 2" F Slip	2
2	000-041-444	Recovery Tank, Cover Dual Vac, Weldment - Coated	1
3	000-052-222	Elbow, 2" Barb X 2" FPT	2
4	000-057-202	Gasket, End - Recovery Tank Cover	2
5	000-057-203	Gasket, Middle - Recovery Tank Cover	2
6	000-057-015	Gasket, 1-1/2" Bulkhead Fitting	2

Item	Part Number	Description	Qty
7	000-057-204	Gasket, Side - Recovery Tank	2
8	000-086-008	Latch, Bungee - Strike	1
9	000-094-063	Nut, #6-32UNC Nylock	2
10	000-143-539	Screw, #6-32UNC X 0.50" Lg. Button Head	2
11	000-078-039	Vacuum Inlet Stopper	1

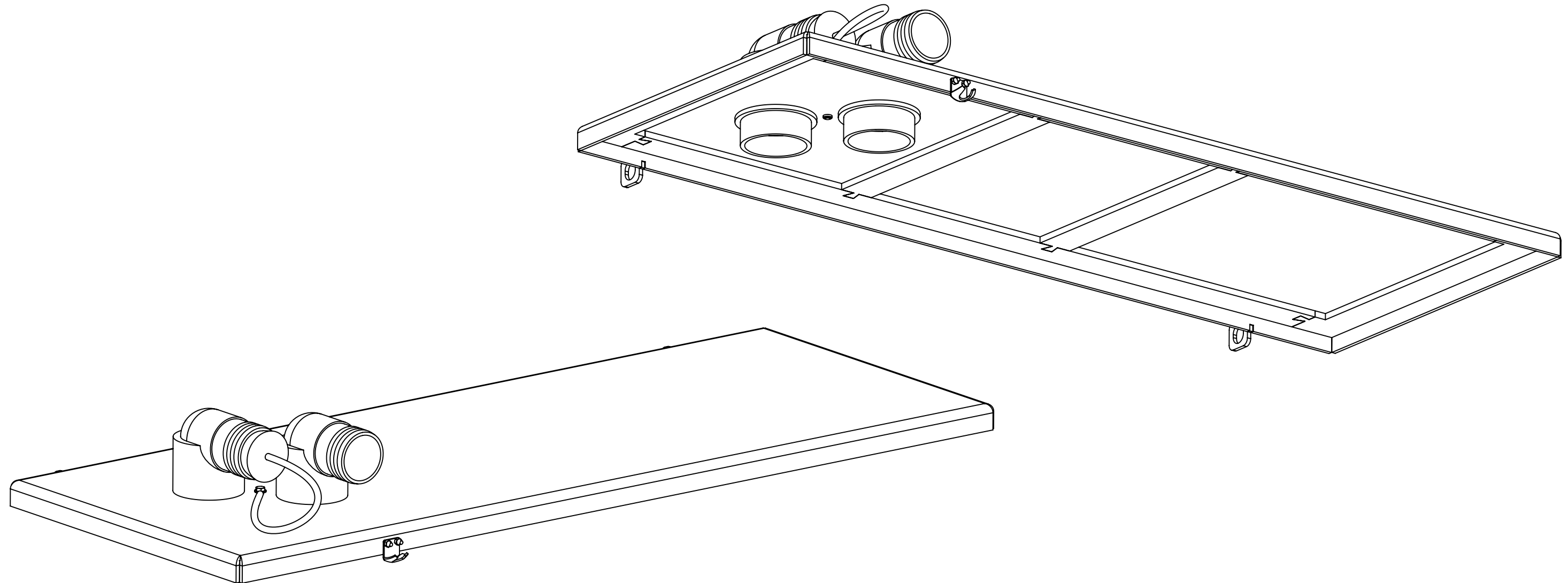
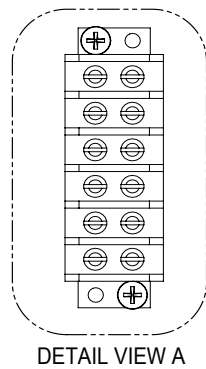
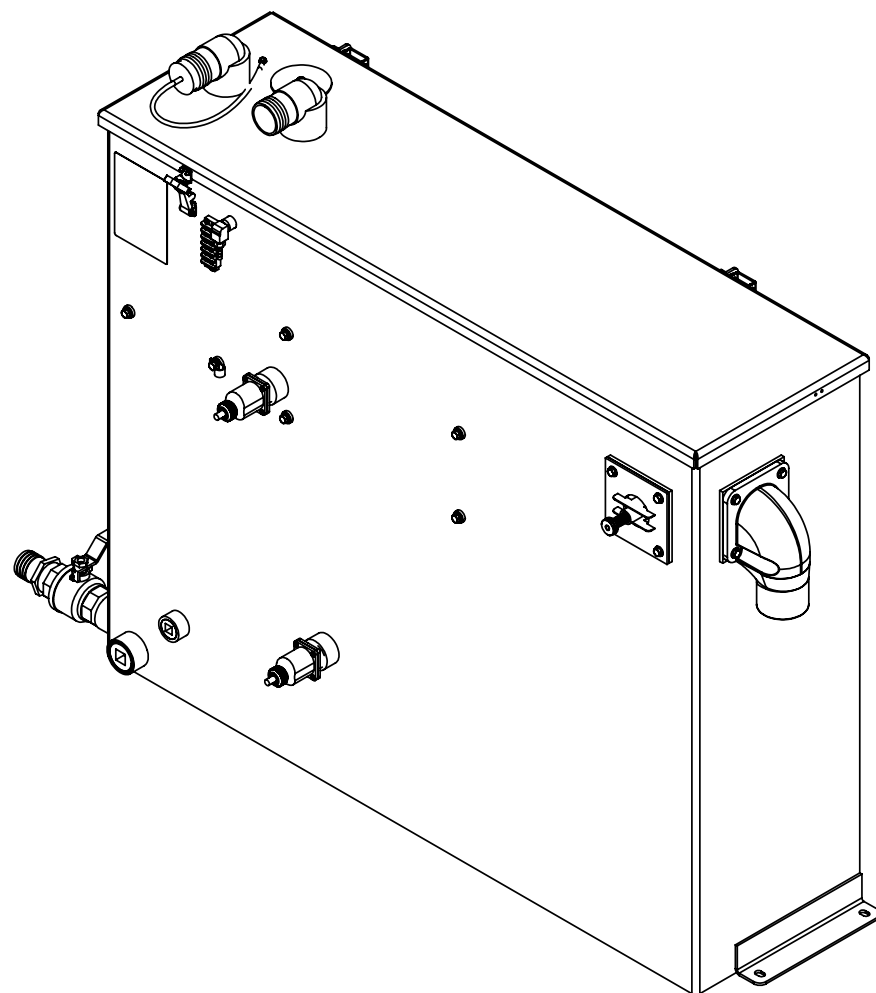

Figure 9-41. 100 Gallon Universal Recovery Tank (URT) Assembly
610-003-080 Rev. G



000-081-332 LABEL, MAINTENANCE AND LUBE SCHEDULE

000-052-763 NIPPLE, 1-1/2" NPT CLOSE SS
000-169-022 VALVE, 1-1/2" FULL PORT BALL
000-052-226 INSERT, 1-1/2" NPT X 1-1/2" BARB

TORQUE TO 40 FT LBS > 19
TORQUE TO 60 FT LBS > 20
TORQUE TO 50 FT LBS > 21

000-157-091 SWITCH, FLOAT LEVEL (AWDS)

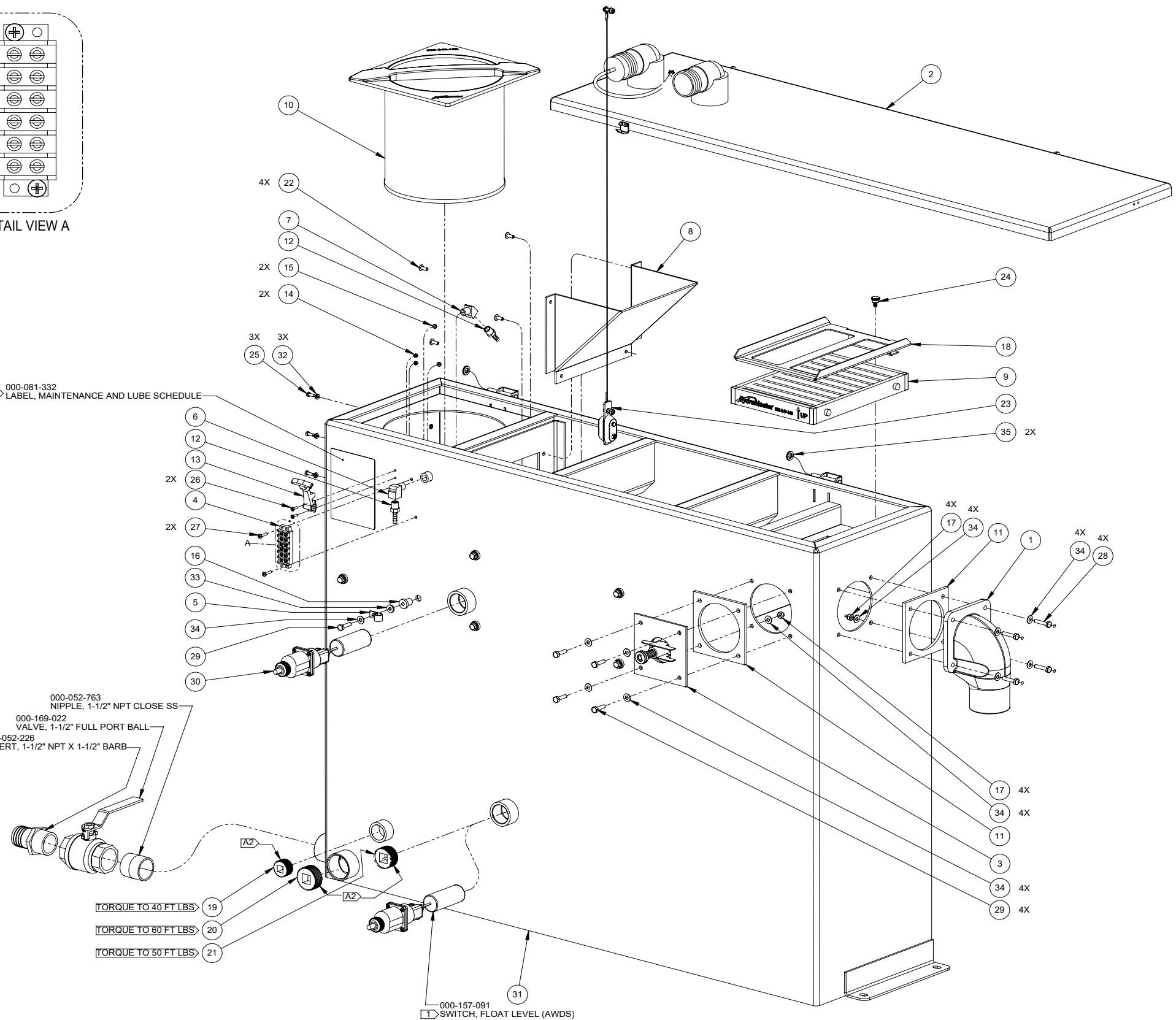

NOTICE

The AWDS is optional equipment. The lower float switch is only used when the AWDS is installed.

TITAN 575

100 Gallon Universal Recovery Tank (URT) Assembly Parts List

Item	Part Number	Description	Qty
1	000-001-135	ADAPTER, Ø3.0 TANK TO x 90° BLOWER HOSE - CASTING	1
2	610-029-001	ASSEMBLY, 100G, REC TANK COVER w/ 2.5" PORT	1
3	610-026-724	ASSEMBLY, VACUUM RELIEF VALVE - URT	1
4	000-012-002	BLOCK, 6 POST TERMINAL	1
5	000-033-046	CLAMP, 1/2" WIDE X 1/2" TUBE	1
6	000-052-085	ELBOW, 1/4" NPT STREET	1
7	000-052-082	ELBOW, 1/4" NPT STREET x 45°	1
8	000-049-154	FILTER, AIR DEFLECTOR, URT - FABRICATED	1
9	000-049-153	FILTER, FLAT - UNIVERSAL RECOVERY TANK	1
10	000-049-152	FILTER, RECOVERY TANK BASKET	1
11	000-057-206	GASKET, ADAPTER - URT	2
12	000-052-100	INSERT,#44	2
13	000-086-008	LATCH, BUNGEE	1
14	000-094-063	NUT, #6-32UNC HEX NYLOCK	2
15	000-094-059	NUT, #8-32UNC HEX NYLOCK	2
16	000-094-113	NUT, 1/4"-20UNC NEOPRENE WELLNUT	6
17	000-094-009	NUT, 1/4"-20UNC NYLOCK	8

Item	Part Number	Description	Qty
18	000-105-785	PLATE, BLOWER FLAT FILTER - ZR	1
19	000-106-049	PLUG, 1" NPT BRONZE	1
20	000-106-019	PLUG, 1-1/2" NPT BRONZE	1
21	000-106-046	PLUG, 1-1/4" NPT BRONZE	1
22	000-140-023	RIVET, AB8-6A ALUMINUM POP	4
23	000-079-226	SACRIFICIAL ANODE, MAGNISIUUM	1
24	000-143-787	SCREW THUMB 1/4-20X3/8	1
25	000-143-126	SCREW, #10-24UNC x 0.50" LG. HEX HEAD	3
26	000-143-539	SCREW, #6-32UNC x 0.50" LG. BUTTON HEAD	2
27	000-143-051	SCREW, #8-32UNC x 0.75" LG. BINDER HEAD	2
28	000-143-010	SCREW, 1/4"-20UNC X 1.25" LG. HEX HEAD S/S	4
29	000-143-002	SCREW, 1/4"-20UNC x 1.00" LG. HEX HEAD	10
30	000-157-091	SWITCH, FLOAT LEVER	1
31	000-159-129	TANK, 100 GAL UNIVERSAL REC - CTD E-01	1
32	000-174-036	WASHER, #10 FLAT RUBBER BACKED	3
33	000-174-060	WASHER, 1/4" FLAT RUBBER BACKED	6
34	000-174-003	WASHER, 1/4" FLAT S/S	17
35	000-174-029	WASHER, 3/8" FLAT RUBBER BACKED	2

Figure 9-42. 100 Gallon Universal Recovery Tank (URT) Cover Assembly
610-029-001 Rev. B

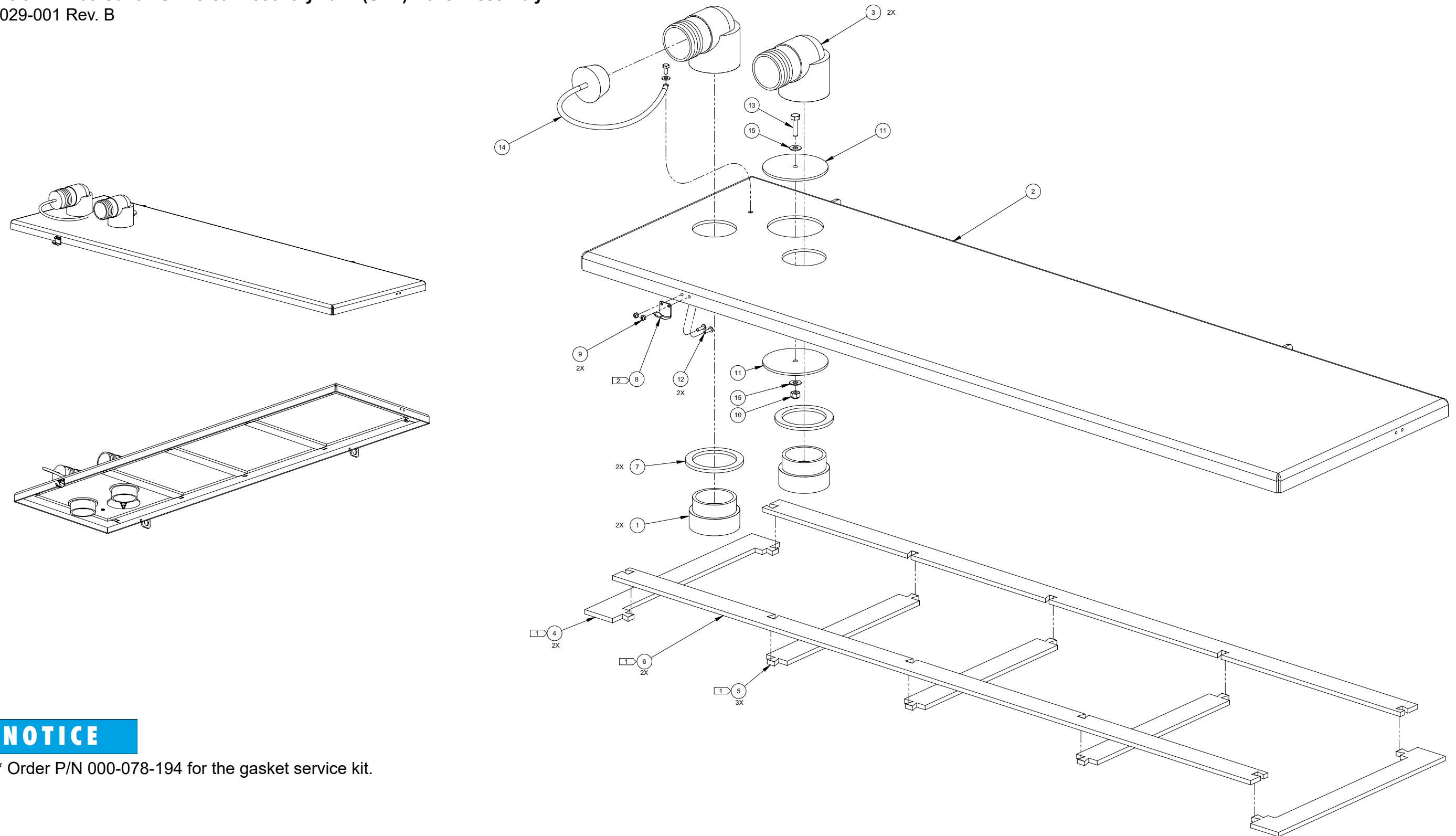

NOTICE

* Order P/N 000-078-194 for the gasket service kit.

TITAN 575

100 Gallon Universal Recovery Tank (URT) Cover Assembly Parts List

Item	Part Number	Description	Qty
1	000-052-219	Adapter, 2" NPT X 2" F Slip	2
2	000-041-928	Cover 100 URT 3 Port w/2.5" Port - Coated - E-01	1
3	000-052-222	Elbow, 2" Barb X 2" FPT	2
4	000-057-202	Gasket, End - Recovery Tank Cover	2
5	000-057-203	Gasket, Middle - Recovery Tank Cover	3
6	000-057-205	Gasket, Side - Recovery Tank Cover	2
7	000-057-015	Gasket, 1-1/2" Bulkhead Fitting	2
8	000-086-008	Latch, Bungee - Strike	1

Item	Part Number	Description	Qty
9	000-094-063	Nut, #6-32UNC Nylock	2
10	000-094-009	Nut, 1/4"-20UNC Nylock	1
11	000-105-546	Plate, Port Cover - Coated	2
12	000-143-539	Screw, #6-32UNC X 0.50" Lg. Button Head	2
13	000-143-002	Screw, 1/4"-20UNC X 1.00" Lg. Hex Head	1
14	000-078-039	Vacuum Inlet Stopper	1
15	000-174-003	Washer, 1/4" Flat	2

Figure 9-43. Vacuum Relief Valve Assembly
610-026-724 Rev. B

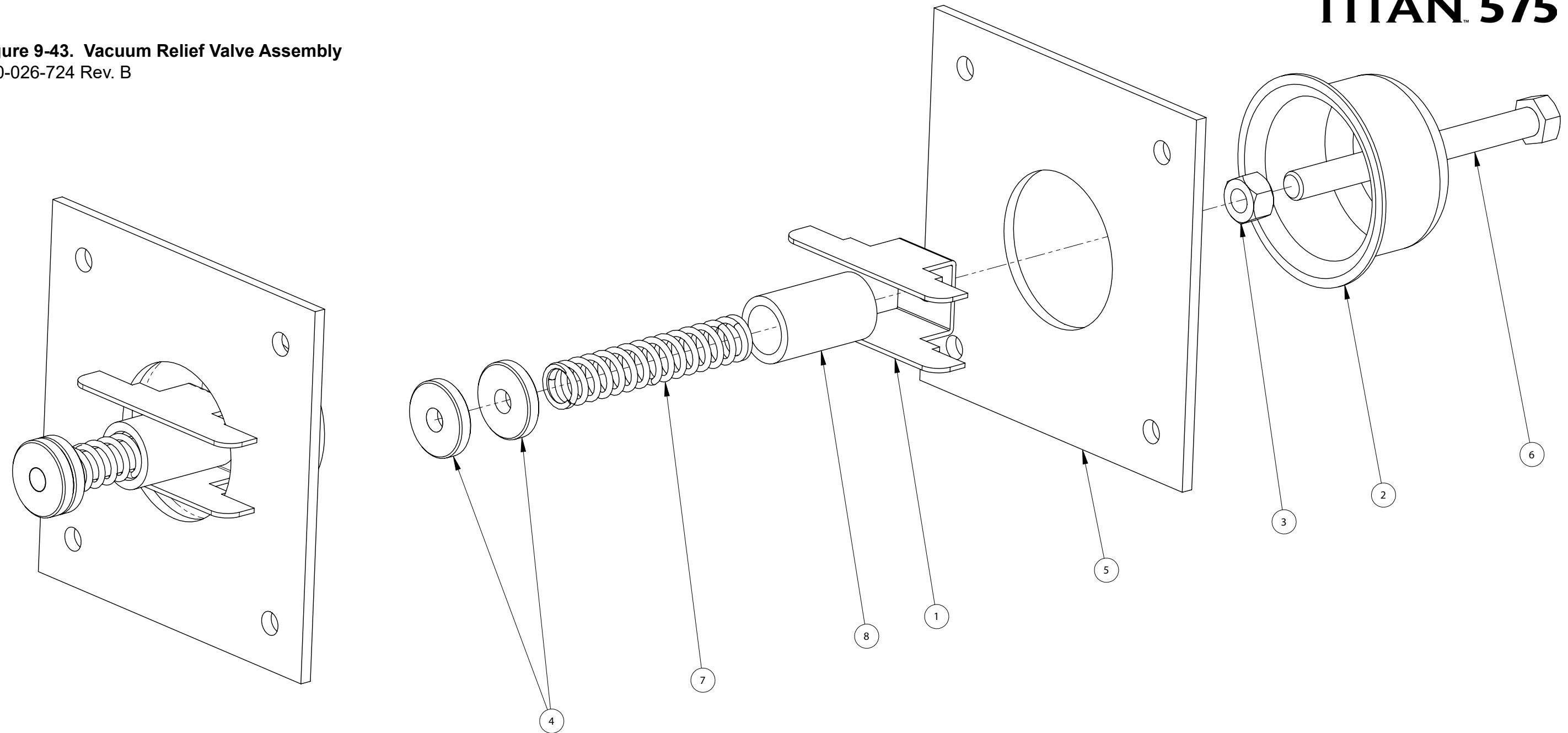

Vacuum Relief Valve Assembly Parts List

Item	Part Number	Description	Qty
1	000-015-182	Bracket, Vacuum Relief Valve - Fabricated	1
2	000-027-032	Cap, Spun Vacuum Relief Valve	1
3	000-094-101	Nut, 3/8"-16 UNC Hex Jam	1
4	000-094-077	Nut, 3/8"-16UNC X 1.00" O.D. Knurled	2

Item	Part Number	Description	Qty
5	000-105-332	Plate, Vacuum Relief Valve Mounting - Coated	1
6	000-143-198	Screw, 3/8"-16UNC X 4" Lg. Hex Head - Full Thread	1
7	000-155-026	Spring, Vacuum Relief Valve	1
8	000-125-111	Tube, Vacuum Relief Spring Guide	1

TITAN 575

Figure 9-44. Vacuum Inlet Stopper Assembly
000-078-039 Rev. B

Vacuum Inlet Stopper Assembly Parts List

Item	Part Number	Description	Qty
1	000-025-008	CABLE, 150 LB. TEST 17.00 LG.	1
2	000-033-032	CLAMP, CDS THROTTLE CABLE	2
3	000-068-025	HOSE, Ø1/4" X 14.00 LG. CLEAR	1
4	000-106-175	PLUG, ROUND TAPERED, BLACK - TRADE SIZE #10	1
5	000-143-166	SCREW, #10-24UNC x 0.375" LG. HEX HEAD	1
6	000-174-001	WASHER, #10 FLAT	1
7	000-174-045	WASHER, #6 S/S FLAT	1

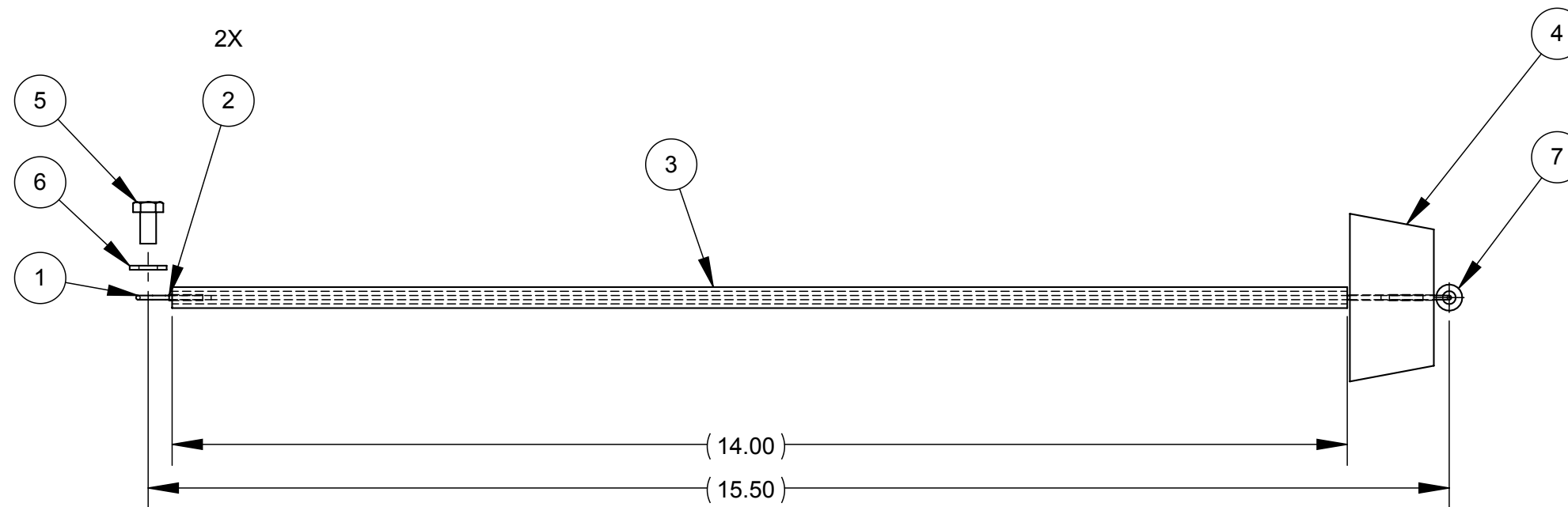
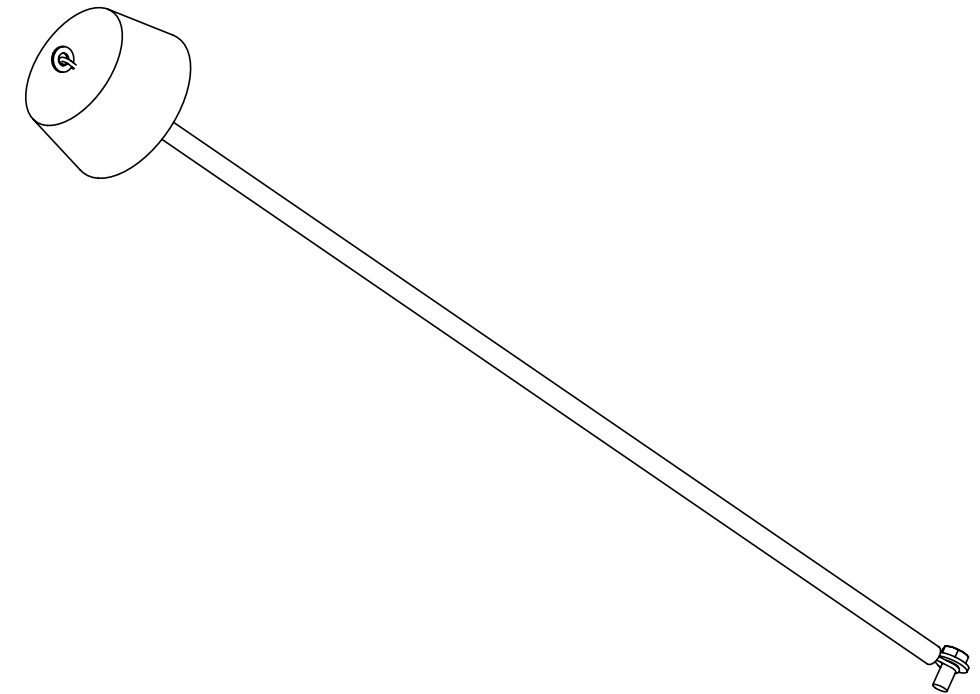

TITAN 575

Figure 9-45. AWDS Universal Kit Assembly
000-079-220 Rev. E

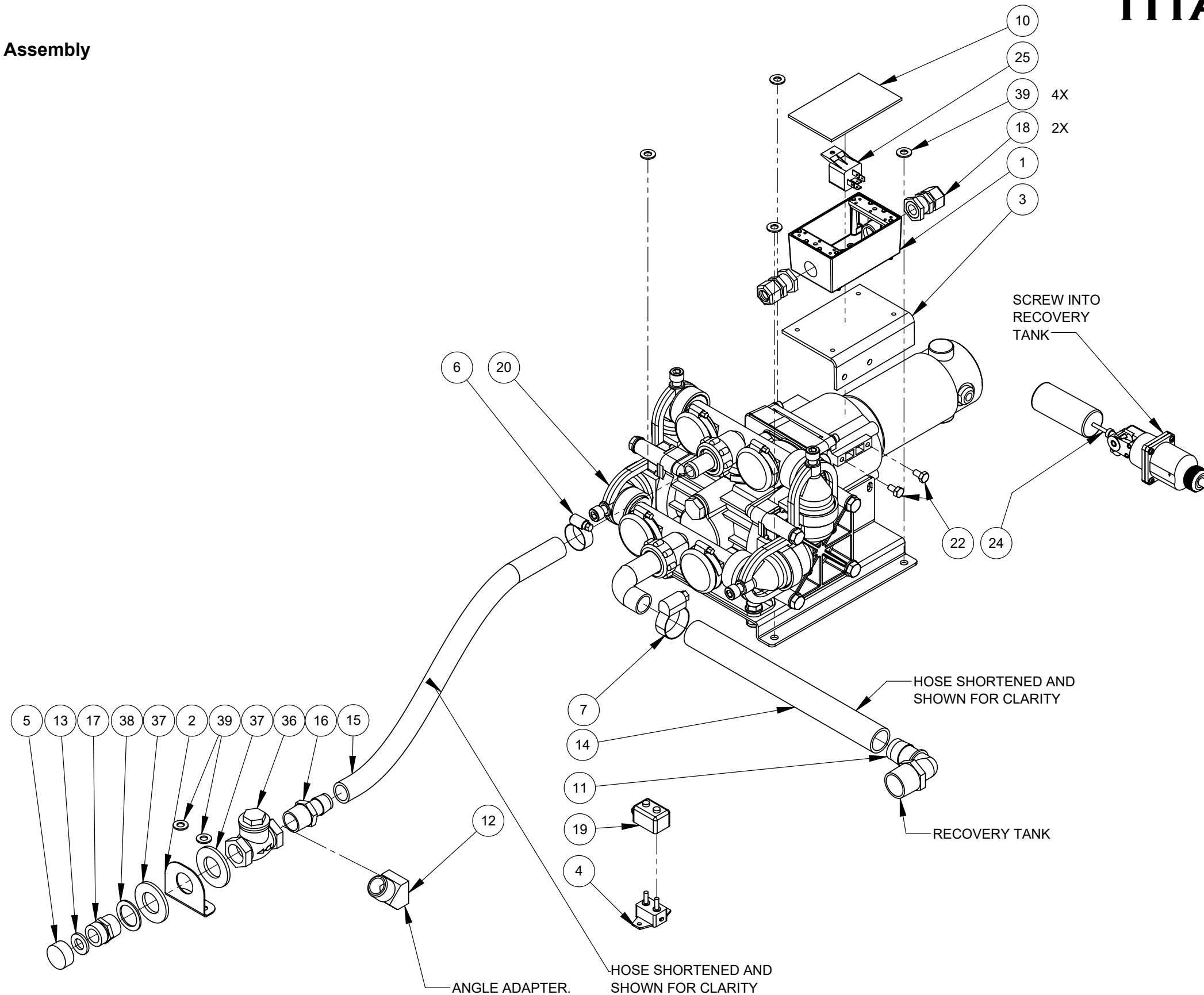

TITAN 575

AWDS Universal Kit Assembly

Item	Part Number	Description	Qty
1	000-013-040	BOX, AWDS ELECTRICAL	1
2	000-015-1331	BRACKET, CHECK VALVE - APO	1
3	000-015-035	BRACKET, ELECTRICAL BOX - AWDS	1
4	000-018-007	BREAKER, 30AMP CIRCUIT	1
5	000-027-014	CAP, GARDEN HOSE	1
6	000-033-029	CLAMP, SIZE #12 HOSE	1
7	000-033-020	CLAMP, SIZE #16 HOSE	1
8	000-037-029	CONN 12 10 WIRE BUTT	4
9	000-037-033	CONN BUTT 14/16 BLUE	2
10	000-041-100	COVER, AWDS ELECTRICAL BOX	1
11	000-052-131	ELBOW, 1" NPT x 1" BARB	1
12	000-052-384	ELBOW, 3/4" NPT X 45°	1
13	000-057-055	GASKET, GARDEN HOSE	1
14	000-068-1086	HOSE, 1" I.D. RUBBER x 72" LG. - RED	1
15	000-068-1091	HOSE, 3/4" I.D. RUBBER x 96"-RED	1
16	000-052-338	INSERT, #1212 (3/4" NPT x 3/4" BARB)	1
17	000-052-281	NIPPLE, 3/4" NPT x 3/4" MALE GARDEN HOSE	1
18	000-108-218	PROTECTOR STRAIN RELIEF W TITE	2
19	000-108-220	PROTECTOR, BREAKER COVER	1
20	000-111-195	PUMP, AWDS 8 GPM 12 VOLT	1
21	000-143-218	SCR 8-32 X 1/2 SELF TAP PHIL	8
22	000-143-074	SCREW, 1/4"-20UNC x 0.50" LG. HEX HEAD	2
23	000-037-077	SOLDERLESS TERMINAL RING 12 10	3
24	000-157-090	SWITCH, LEVER FLOAT HARWIL	1
25	000-157-022	SWITCH, RELAY 12V	1
26	000-037-016	TERM 10 RING 12 AWG	2
27	000-037-014	TERM 10 RING 16 AWG	1
28	000-037-017	TERM 10-12 AWG 3/8 RING YEL	2
29	000-037-022	TERM 10-12 AWG FEM INSUL YEL	1
30	000-037-025	TERM 8 BLOCK SPADE 14 16 GAUGE	2

Item	Part Number	Description	Qty
31	000-037-073	TERM BLOCK SPADE 22 16 GA FORK	1
32	000-037-009	TERM FULLY INSUL MALEQ C	1
33	000-037-012	TERM FULLY INSULATED FEMALE Q	1
34	000-037-071	TERM INSUL FEM 22-16 AWG RED	2
35	000-162-002	TIE WRAP-6 NYLON	10
36	000-169-009	VALVE, 3/4" FPT SWING CHECK	1
37	000-174-050	WASHER, 1" FLAT	2
38	000-174-063	WASHER, 1.5" O.D. x 1.073" I.D. x 0.075" THK.	1
39	000-174-049	WASHER, 5/16" FLAT	6
40	000-178-063	WIRE 12 GXL BLACK BULK	20'
41	000-178-015	WIRE 12 GXL RED BULK 12 19BC G	20'
42	000-178-068	WIRE 18 GXL BROWN BULK 18 19BC	6'
43	000-178-069	WIRE 18 GXL WHITE BULK 18 19BC	6'

ITEMS 7, 8, 21, 23, 26, 27, 28, 29, 30, 31, 32, 33, 34, 35, 40, 41, 42, AND 43 ARE NOT SHOWN.

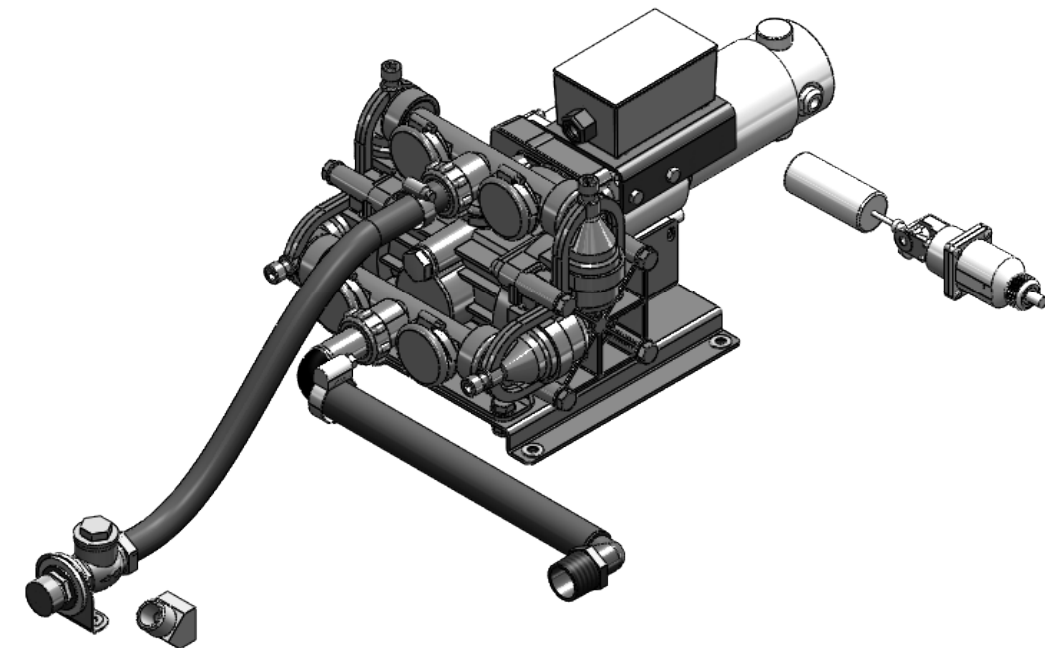

TITAN 575

Figure 9-46. High Pressure Washing Kit - Pump Assembly
610-021-013 Rev. B

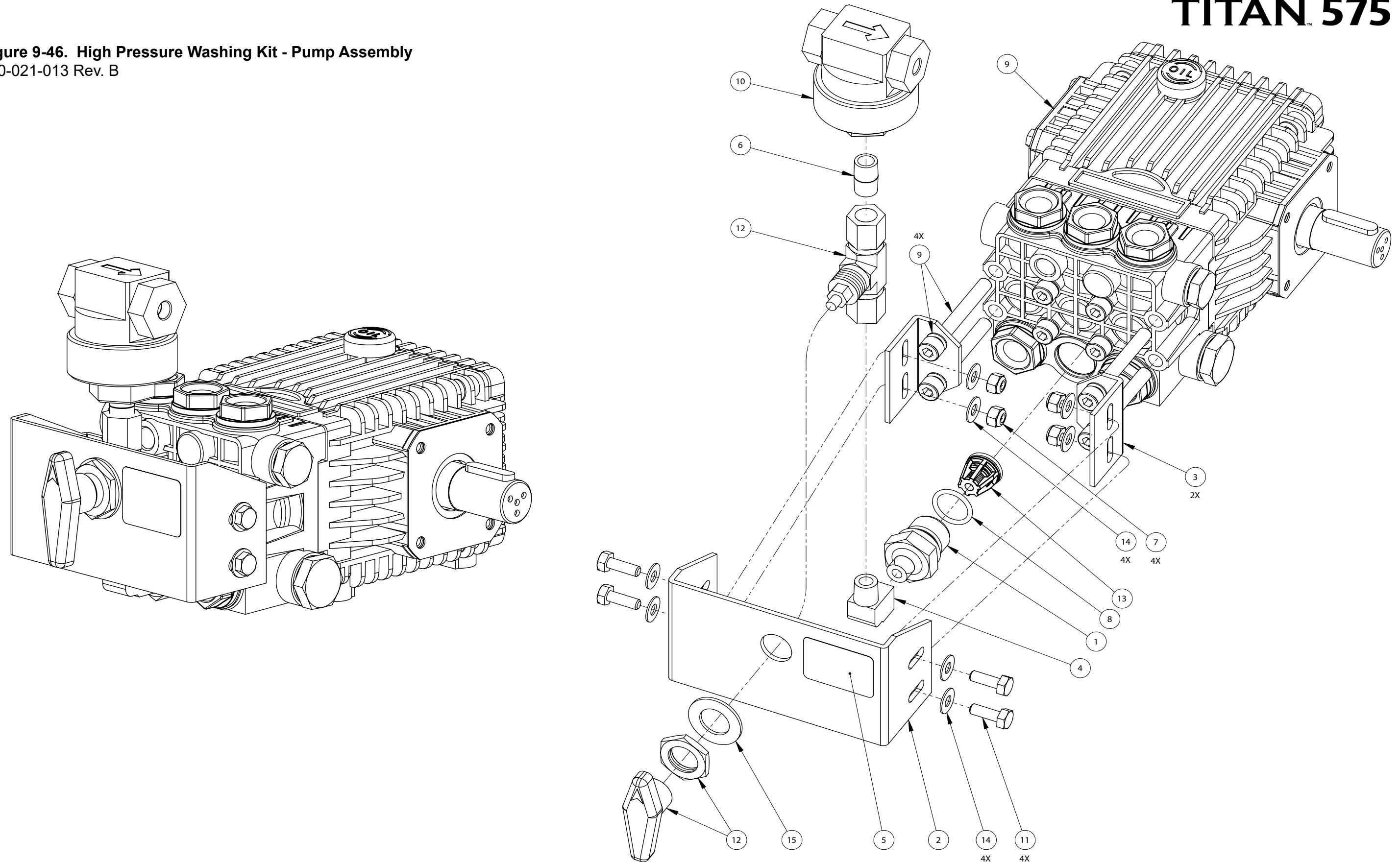

TITAN 575

High Pressure Washing Kit - Pump Assembly Parts List

Item	Part Number	Description	Qty
1	000-001-154	Adapter, GP to Chem Pump S/S 4.0 Gallon	1
2	000-015-253	Bracket, Chem Pump Main Support - Coated	1
3	000-015-254	Bracket, Chem Pump Mount - Coated	2
4	000-052-085	Elbow, 1/4" NPT Street	1
5	000-081-306	Label, Chemical Pump Shut Off	1
6	000-052-517	Nipple, 1/4" NPT Close	1
7	000-094-009	Nut, 1/4"-20UNC Nylock	4
8	000-097-057	O-Ring, Adapter - Chemical Pump	1

Item	Part Number	Description	Qty
9	000-111-188	Pump, 4.0 gpm GP	1
10	000-111-184	Pump, GP Chemical	1
11	000-143-001	Screw, 1/4"-20UNC X 0.75" Lg. Hex Head	4
12	000-169-176	Valve, 2-Way Chem Pump	1
13	000-169-221	Valve, GP Pump Check - Mod. - 4.0 Gallon	1
14	000-174-003	Washer, 1/4" Flat	8
15	000-174-027	Washer, 3/4" Flat - Brass	1

Figure 9-47. High Pressure Washing Kit - Lower Left Dash Assembly
610-021-014 Rev. C

High Pressure Washing Kit - Lower Left Dash Assembly Parts List

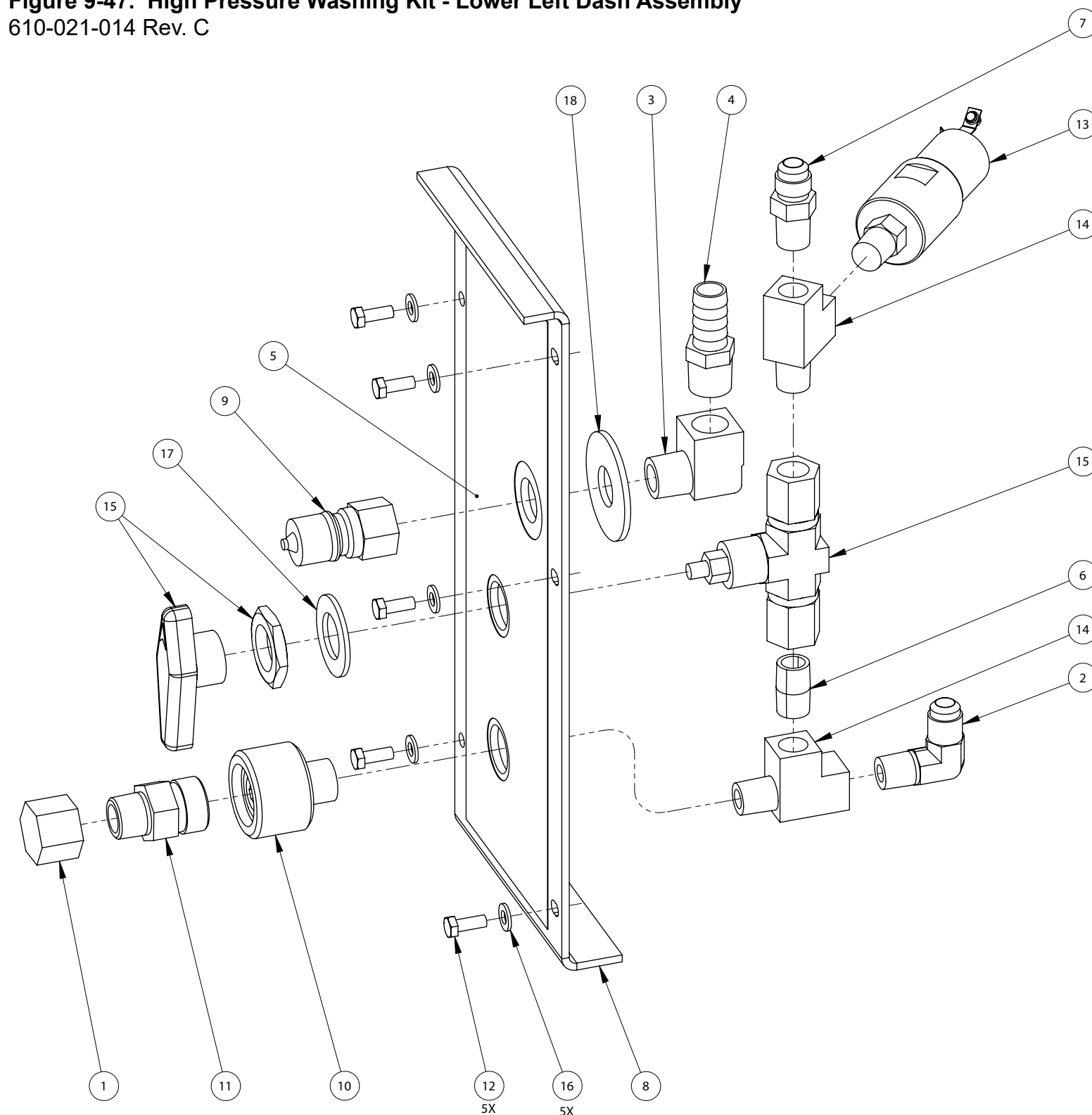

Item	Part Number	Description	Qty
1	000-027-008	Cap, 3/8" Brass Pipe	1
2	000-052-751	Elbow, 3/8" JIC X 1/4" NPT	1
3	000-052-086	Elbow, 3/8" NPT Street	1
4	000-052-105	Insert, #68 (3/8" NPT X 1/2" Barb)	1
5	000-081-305	Label, Lower Dash - Left - Pressure Washing	1
6	000-052-072	Nipple, 1/4" NPT Close	1
7	000-052-533	Nipple, 3/8" JIC X 1/4" NPT	1
8	000-100-188	Panel, Lower Dash, Left, Pressure Washing - Coated	1
9	000-052-052	Quick Connect, 660 3/8" Brass w/ EPDM O-Ring	1
10	000-052-769	Quick Connect, High PSI Female 1/4" NPT	1
11	000-052-768	Quick Connect, High PSI Male 1/4" NPT	1
12	000-143-126	Screw, #10-24UNC X 0.50" Lg. Hex Head	5
13	000-157-157	Switch, Nason 1,350 psi Shutoff	1
14	000-052-090	Tee, 1/4" NPT Branch M-F-F	2
15	000-169-214	Valve, 2 Way Chem Pump - 1/4" FPT S/S	1
16	000-174-001	Washer, #10 Flat	5
17	000-174-027	Washer, 3/4" Flat - Brass	1
18	000-174-008	Washer, 5/8" Flat	1

TITAN 575

Figure 9-48. Sacrificial Anode Assembly
000-079-226 Rev. B

Sacrificial Anode Assembly Parts List

Item	Part Number	Description	Qty
1	000-015-1413	BRACKET, SACRIFICIAL ANODE - FABRICATED	1
2	000-025-098	CABLE, 1/16 S-STEEL - 31"	1
3	000-033-149	CLAMP, WIRE SLEEVE 1/16Ø S-STEEL	2
4	000-094-034	NUT, #10-24UNC HEX NYLOCK	2
5	000-094-150	NUT, 10-24 S/S NYLOK HALF	2
6	000-108-025	PROTECTOR, MAGNESIUM ANODE - UNMODIFIED	2
7	000-143-132	SCREW, #10-24UNC x 0.75" LG. HEX HEAD	2
8	000-143-171	SCREW, #10-24UNC x 1.25" LG. HEX HEAD	2
9	000-174-015	WASHER, #10 EXTERNAL STAR	1
10	000-174-001	WASHER, #10 FLAT	4

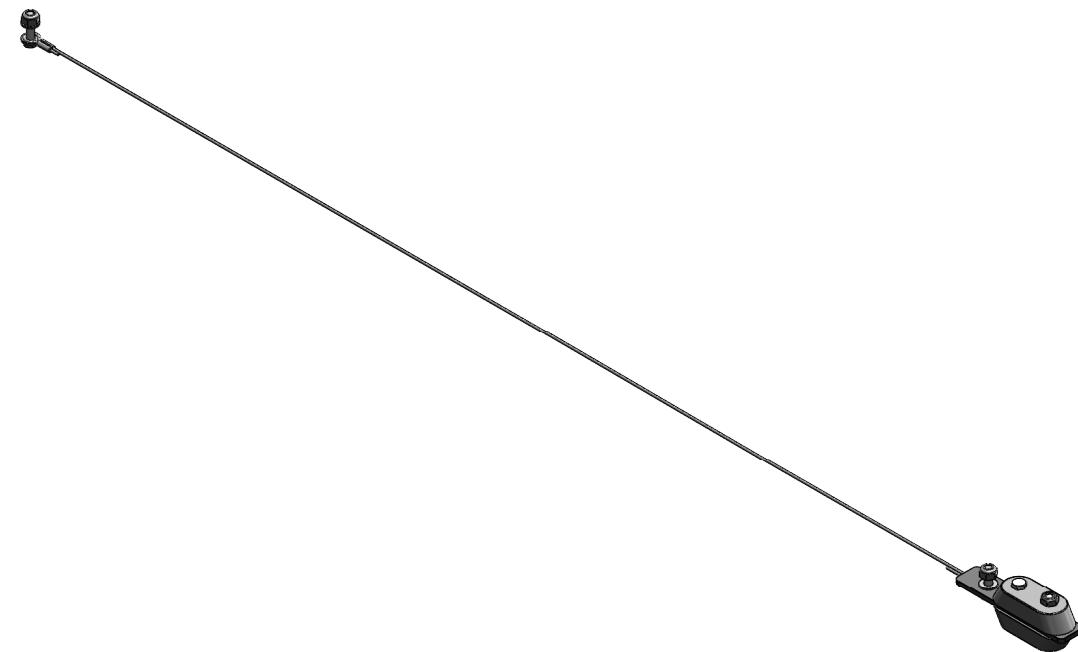
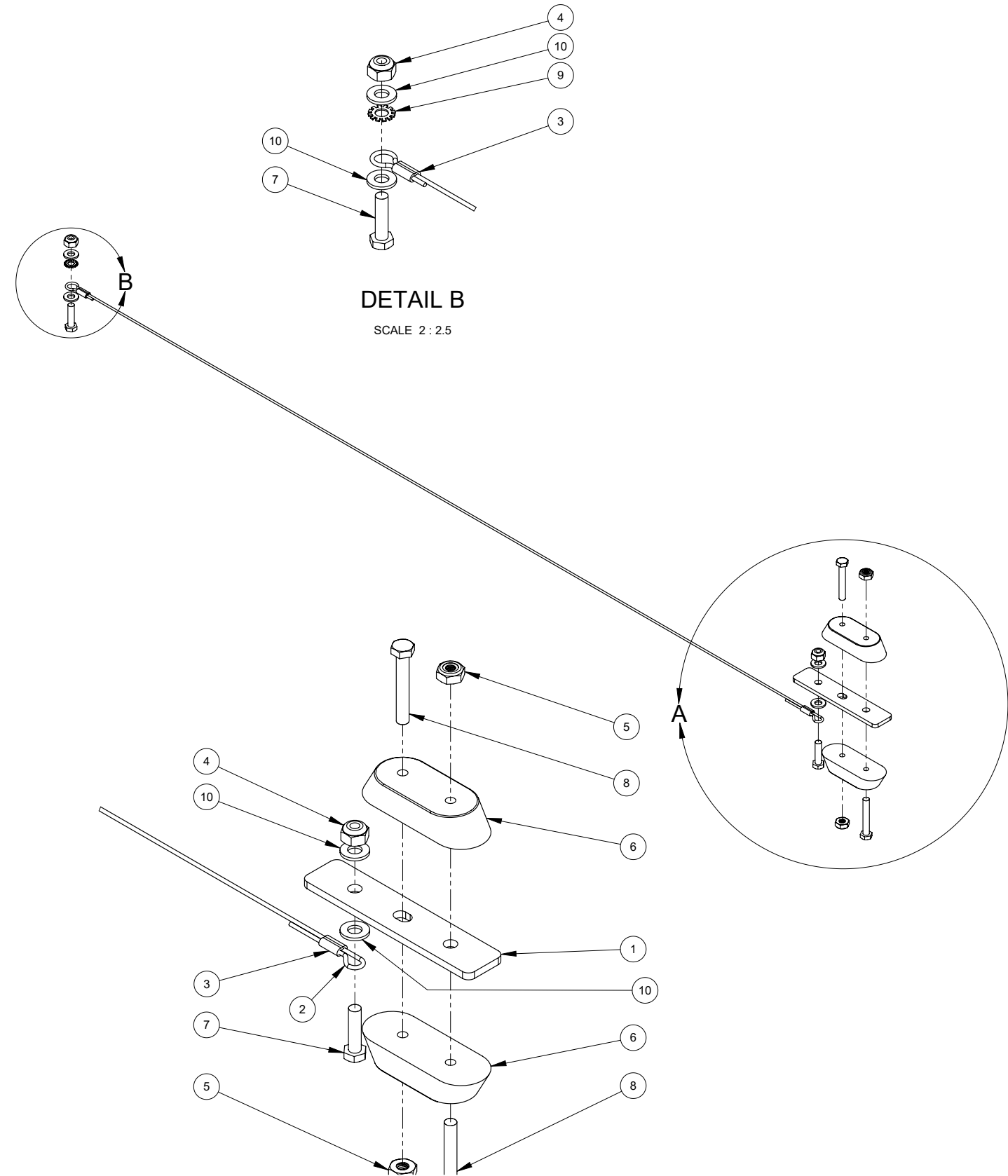

10 - How to Order Parts

To order warranty replacement parts or repairs, it is important that you read this section which includes:

- Warranty Parts Orders
- Parts Orders
- Emergencies

WARRANTY PARTS ORDERS

1. Call the local distributor where you purchased your equipment and ask for the Service Department.
2. Have the following information ready:
 - a. Equipment Model
 - b. Date of Purchase
 - c. Unit Serial Number, if applicable
 - d. Description of Malfunction
3. Once it has been determined which parts are needed to correct the problem with your machine, make arrangements with your distributor to either perform the repairs or ship the parts to you.

Any questions you have regarding the warranty program should be directed to the Customer Service Department at 800-333-4757, 7 a.m. to 5 p.m. Monday through Friday (PT).

We shall always endeavor to be fair in our evaluation of your warranty claim and shall provide you with a complete analysis of our findings. Diagnostic reimbursement is specifically excluded.

PARTS ORDERS

Call your local distributor. In most instances, they either stock or have access to parts through a regional service center.

EMERGENCIES

If, for any reason, your distributor is unable to supply you with the necessary parts, they may call us and arrange for expedited shipping.

HydraMaster sells parts only through authorized distributors and service centers.

11 - Warranty Information

To avoid misunderstandings which might occur between machine owners and the manufacturer, we are listing causes of component failure that specifically voids warranty coverage. Such causes listed in this section shall constitute abuse or neglect.

BLOWER

- Failure to lubricate impellers daily with a HydraMaster-recommended lubricant, to lubricate bearings, to maintain proper oil levels, or to use the correct oil grade and viscosity as recommended in blower manual.
- Failure to properly maintain blower safeguard systems such as waste tank filter screen, vacuum safety relief valve and waste tank automatic shut-off system.
- Allowing foam to pass through blower.

HIGH PRESSURE WATER PUMP

- Failure to maintain proper oil level as recommended in pump manual.
- Failure to change oil in pump at recommended intervals.
- Failure to protect pump against freezing.
- Failure to maintain pump protection shut-off system.
- Failure to use water softener in hard water areas.
- Use of improper chemicals.

VACUUM TANK

- Failure to properly maintain filtering devices in tank.
- Failure to clean tank as recommended by manufacturer.
- Failure to maintain vacuum safety release in tank.
- Use of improper chemicals.

CHEMICAL SYSTEM

- Use of improper chemical.
- Failure to use water softener in hard water area.
- Operating machine without proper chemical filter screen.
- Failure to protect against freezing.

CONTROL PANEL

- Failure to protect flowmeter and water pressure gauge against freezing.

TITAN™ 575

VACUUM AND SOLUTION HOSES

- Failure to protect hoses against freezing.
- Failure to protect hoses against burns from engine and blower exhaust.
- Damage to hoses from being run over by vehicles.
- Kinking or cracking from failure to store or unroll hoses correctly.
- Normal wear and tear from everyday use.

CLEANING WAND AND TOOL

- Failure to protect against freezing.
- Obvious physical abuse of wand or tool.

WATER HEATING SYSTEM

- Over-pressurization of the system (recommended maximum working pressure - 1,200 psi).
- Failure to protect against freezing.

HARD WATER DEPOSITS

- Failure to use or maintain a water softening system or a properly installed magnetic-type descaler, whichever might be necessary, with machines operating in designated “Hard Water Areas” (3.0 grains or more per gallon).

WARRANTY PROCEDURE

Warranty coverage is available to you through your local distributor.

If you have moved to a new area or have purchased a used machine and need information regarding your local distributor, call HydraMaster at (800) 426-1301 or email us at: techsupport@hydramaster.com.

When calling your distributor, be sure to have the machine’s information; model and serial number, ready for the service representative.

TITAN 575

HYDRAMASTER[®] STANDARD SLIDE-IN LIMITED WARRANTY

HydraMaster warrants to the original end user, each new machine, new accessories and genuine replacement parts against defects in material and workmanship under normal use and service. Our obligation under this warranty is limited to repair or replacement of the defective item at our factory or by an Authorized Service Center. Warranty coverage shall begin on the date of purchase by the original end user (as evidenced by your invoice from the factory or Authorized Dealer) or six (6) months from the date the machine was shipped from the factory, whichever is earlier. The warranty registration card must be completed and returned within 30 days of purchase. The warranty coverage period is specified below.

GROUP	Parts ^{1,2}	Labor ²
Frame	3 Years	2 Years
Covers	3 Years	2 Years
Vacuum Recovery Tank (Structural only)	3 Years	2 Years
Vacuum Pump – see Note 3	2 Years	2 Years
Chemical Systems	2 Years	2 Years
Hoses, Internal Machine	2 Years	2 Years
Hoses, External Machine	2 Years	2 Years
Valve, High pressure bypass	2 Years	2 Years
Water Heating System	2 Years	2 Years
Pump, High pressure water	2 Years	2 Years
Belts	2 Years	2 Years
Fittings, internal machine	2 Years	2 Years
Filter Screens	2 Years	2 Years
Gauges	2 Years	2 Years
Electrical Components	2 Years	2 Years
Engine	See Note 3	2 Years
Accessories and Fresh Water Tanks	1 Year	1 Year
Replacement Parts – see Note 4	90 Days	NA

NOTES:
1-Parts repaired or replaced are guaranteed for the remainder of the original machine warranty period.
2-Coverage only applicable to products sold and used in the United States and Canada.
3-As provided by the original Manufacturer.
4-Applies to replacement parts only after machine warranty coverage has expired.

This warranty shall not apply to repairs resulting from accidents or misuse, damage in transit, overloading the capacity of the machine, failure due to lack of proper maintenance or care as described in the operating and maintenance instructions. Freezing of any water or chemical related component will VOID all warranties on water or chemical related components, internal or external. Corrosion, deposits and/or build-up in the water, chemical, recovery or heating systems due to hardness in the water used or chemicals which result in deposits, will VOID all warranties on affected components. The use or application of any chemical, including but not limited to acids or solvents, which results in damage to metal, rubber, plastic, or painted parts will VOID all warranties on those parts. Minor adjustments, such as tightening of screws or bolts not connected with the replacement of parts, are not covered. Replacement of expendable wear items including, but not limited to paint, labels and other cosmetic parts are also not covered. Repairs or alterations by an organization other than the factory or an Authorized Service Center are not covered and will void any HydraMaster warranty as to the parts or systems repaired or altered by a non-authorized organization.

THERE ARE NO WARRANTIES THAT EXTEND BEYOND THE DESCRIPTION OF THE LIMITED WARRANTIES STATED WITHIN. NO OTHER WARRANTY, EXPRESSED OR IMPLIED, INCLUDING BUT NOT LIMITED TO ANY IMPLIED WARRANTY OF MERCHANTABILITY OR FITNESS FOR A PARTICULAR PURPOSE, IS MADE EXCEPT AS EXPRESSLY STATED HEREIN. ANY STATUTORY IMPLIED WARRANTIES, INCLUDING ANY WARRANTY OF MERCHANTABILITY OR FITNESS FOR A PARTICULAR PURPOSE, THAT ARE IMPOSED BY LAW DESPITE THE EXPRESS LIMITATION OR WARRANTIES ABOVE, ARE EXPRESSLY LIMITED TO THE DURATION OF THE WRITTEN WARRANTY. BUYER UNDERSTANDS, ACKNOWLEDGES AND AGREES THAT THE REMEDIES PROVIDED UNDER THIS LIMITED WARRANTY ARE THE SOLE AND EXCLUSIVE REMEDIES AVAILABLE TO THE BUYER. HYDRAMASTER WILL NOT BE LIABLE FOR ANY OTHER OR ADDITIONAL DAMAGES, INCLUDING BUT NOT LIMITED TO INDIRECT, SPECIAL OR CONSEQUENTIAL DAMAGES ARISING OUT OF OR IN CONNECTION WITH THE FURNISHING, PERFORMANCE, USE OF OR INABILITY TO USE THE MACHINE. ANY EXTENSIONS OF OR MODIFICATIONS MADE TO THIS WARRANTY BY A DEALER/DISTRIBUTOR OF HYDRAMASTER ARE THE SOLE RESPONSIBILITY OF THE DEALER/DISTRIBUTOR.

HydraMaster will pay all freight and transportation charges within the United States, via normal ground shipping means, for replacement of parts covered under this warranty. All material must be properly authorized by HydraMaster prior to being returned. When returning, please provide an explanation of the problem and include the serial number of the machine as well as the name of the selling organization. All defective material must be returned to HydraMaster within 60 days of authorization. The Technical Service department of the authorized Dealer Service Center or the factory will investigate and then contact you.

Transportation of hazardous waste or contaminated equipment is subject to various laws and regulations. In returning machines, parts, or accessories under this limited warranty, the end user must certify in writing that the machines, parts or accessories being returned have not been used for handling, clean up, or disposal of hazardous waste or hazardous materials including but not limited to such things as asbestos, anthrax etc. or if the machines, parts or accessories being returned have been used for handling, clean up, or disposal of hazardous waste or hazardous materials, then the end user must have the machines, parts or accessories decontaminated by licensed and qualified decontamination professionals and provide written certification of this decontamination signed by the decontamination professionals. These machines, parts or accessories are to be returned only to the local HydraMaster Authorized Service Center for Warranty service along with decontamination certification.

HydraMaster reserves the right to change its warranty policy without notice.

12 - Accessories and Chemical Solutions

HydraMaster's machine accessories are the most innovative collection available in the cleaning industry. For example, our RX20 Next Gen™ Rotary Extractors have changed the shape of steam cleaning. In addition, our hoses, reels and tanks are of the finest quality construction.

Our carpet care and hard floor care chemical solutions have been specially prepared, not only to give you exceptional cleaning, but also to optimize your truckmount's operation and reliability. HydraMaster's chemical solutions will help maintain your machine's water pump and water heating systems at peak efficiency and also help ensure fewer breakdowns.

HydraMaster's full line of machine accessories and chemicals can enhance cleaning performance while reducing your labor costs, and include:

- Upholstery Tools
- Wands
- Vacuum Hoses
- Tanks
- Van Accessories
- Hose Reels
- Carpet Care Detergents
- Rinse Agents
- Pre-Sprays
- Hard Floor Care Detergents
- De-Foamers and Descalers
- Deodorizers and Disinfectants
- Spotting Agents

For more information about our full line of accessories and chemical solutions, refer to the HydraMaster website at <http://www.hydramaster.com>.

To order genuine HydraMaster accessories and chemical solutions, call your nearest authorized HydraMaster Distributor.